

ELK-C1M1 LTEV ElkCommBd Communicator

Instructions / Specifications

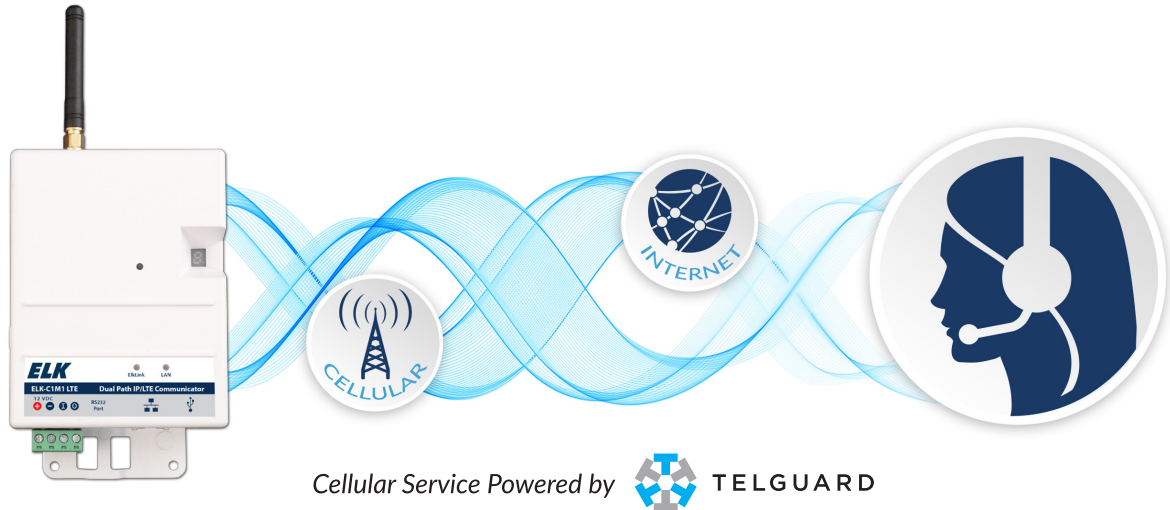

Applications and Overview

The C1M1 LTEV ElkCommBd is a dual path alarm communications device for use with the ELK-M1G Control family. It is the ideal solution for backing up or replacing old fashioned phone line communications. C1M1 is configured to send full data messages using Internet (IP) as the primary pathway and Cellular as backup. It may also be configured for single path operation in situations where one of the paths (IP or Cellular) is not available. In the dual path configuration the C1M1 will automatically report the temporary outage of either pathway over the remaining pathway. Periodic automatic test reports configured in the M1 will be sent over both pathways for ultimate reliability and peace of mind. All communications between the C1M1 and the Central Monitoring Station is encrypted and secure.

Service and Setup

Cellular service is handled via a cooperative partnership between Elk and Telguard Online. Telguard is a division of Telular® Corporation, an industry pioneer and leader in cellular alarm communications. Activation and setup will be handled through the Telguard Online website. Once a unit has been activated, management of the Central Station reporting parameters and paths is handled through the ElkLink website. Installing Dealers will need an online account for both websites. Existing Telguard Installing Dealers can use the same account and login credentials they already have.

General Description and Operation

C1M1 mounts easily inside the 14" or 28" ELK-M1 metal enclosures. (ELK-SWB14 or ELK-SWB28) Both provide a knockout for the cellular antenna as well as a screw hole and zip-tie basket handle for permanent mounting. C1M1 is shipped with a screw-on dipole antenna.

C1M1 operational status is displayed via 3 discrete LED indicators along with a seven (7) segment display.

Only 3 wiring connections are needed to complete the installation. These are: Serial cable to the M1 RS232 Main Port 0, 12VDC power from the M1 Aux. power output, and a CAT5/6 network cable (not supplied) to the premise's IP (LAN) network router.

An optional USB port (type "B" mini) is conveniently available on the C1M1 for connection of a local PC. This allows ElkRP software to be used for local programming of the M1 Control.

NOTICE: Drawings, illustrations, diagrams, part numbers, etc. are provided as reference only and are based on equipment available at the time the information was created. All information contained in this document are subject to change without notice.

Specifications

Operating Voltage:	12VDC
Standby Current:	85 mA
Max. Operating Current:	230 mA
Frequencies Supported:	800/1900MHz
FIPS 197 compliant:	Certificate No. 3352
Dimensions:	3.5" x 5.4" x 1.3"
Operating Environment:	Indoor Use Only; 32-120°F (0-49°C), 0-85% humidity (non-condensing)
Supplied Antenna:	Dipole screw-on
Connections:	
Power and I/O:	4 position plug-in terminals
LAN (Local Area Net):	RJ45 10/100 Receptacle
RS232 Input Port:	3-wire Serial to DB9M cable
USB Serial Port:	Type "B" USB Mini

Included Accessories

36" max., 3-wire RS232 Serial to DB9M Cable (To M1 Control)

Optional Accessories available for Purchase

ELK-USBCM USB Serial A to mini-B cable, 60", Black

HARDWARE OVERVIEW

Dipole Antenna

Cell (Service) Green LED

ON solid is the expected indication of a Cell tower within range and that the unit has established a connection.

Blinking indicates limited or no service.

LAN (Activity) Green LED

Blinking is the expected indication of network communications active with a Local Area Network (LAN)

ElkLink (Connect) Orange/Yel LED

On solid is the expected indication of the C1M1 being connective and active with the ElkLink intermediate server portal. Note: Continuous connection to ElkLink is not mission critical for CS reporting. This LED may be off for short time periods.

Removable Terminal Block

Power Input (12 VDC)

This power shall be supplied from an Aux. Power output on the M1 Control.

Input

Not currently enabled - future use

Output

Not currently enabled - future use

RS232 Cable (3 Wire)

C1M1 ships with a 36" serial cable plugged into this port. A DB9M connector on the other end of this cable plugs directly to the Main RS232 Serial Port on the M1 Control.

WARNING: Max. Cable Length is 36"

Do NOT disconnect, splice or extend this serial cable. Evidence of such action will **VOID PRODUCT WARRANTY.**

LAN (IP) Port

For connection to client's LAN (Local Area Network) for Dual Path communications. If LAN is not available, C1M1 may be used in single path (Cellular Only) operation mode.

Per UL requirements, when utilizing the LAN (IP) Port an Isolated Loop Circuit Protector mfg by APC Model #PNET1GB shall be purchased and installed.

USB Port (Mini B)

Allows local ELK-RP programming of M1 using a PC and a USB serial cable.



7 Segment Display

Sequentially displays 1 character at a time to reveal: Signal Strength, Error Codes, IP Address. Data is grouped in short packets with a key letter prefix. It also displays communications activity.

b bars of cell signal - The letter is followed by a single digit from 0 to 5.

Example: **b 3** reveals 3 bars of service.

E Errors - The letter is followed by two digits. Examples of error codes are:

- E01** = Application not loaded
- E02** = Radio Module Power Fail
- E03** = No SIM card installed.
- E04** = Inactive Unit
- E05** = Low (Poor) Signal Strength
- E06** = No Service or unregistered on Cell Network
- E07** = Unable to communicate with M1
- E08** = Cellular radio module not detected
- E09** = No Internet Service (LAN detected)
- E10** = No LAN detected (check cable)
- E11** = Central Station not configured in ElkLink
- E12** = CS Receiver failed to respond
- E13** = No DHCP Server found

A Address - The LAN IP address is displayed 1 character at a time during the first 2 minutes after power up. C1M1 supports IPv4 addresses. These consist of 4 octets having a value of 0 to 255. Each octet will be separated by a decimal point.

Example: **A 192.168.0.100**

NOTE: CS reports will take priority over the LAN IP display which can make it difficult to view the address sequentially during power up. If needed the LAN IP display may be manually restarted by removing the cover from the C1M1 and pressing the small tamper switch button 5 times quickly. Always replace the cover when done.

Communications Activity:

□ Communications to the Central Station will be displayed as a clockwise rotation of the outer 6 elements on the display. A decimal point in the the lower right corner will illuminate if the report is being send by IP (Ethernet).

⊞ Communications to ElkLink will be displayed as a figure 8 circulation of all 7 elements on the display.

⊞ Communications via the USB serial port will be displayed as a clockwise rotation of the lower 4 elements on the display.

QUICK START GUIDE

1: Establish a Telguard dealer account

Before activating a C1M1 device you will need to register and establish a Telguard Online account. Contact Telguard customer support for more information. This step may be skipped if you already have a registered account with Telguard.

2: Establish an ElkLink dealer account

Before activating a C1M1 device you will need to register and establish a ElkLINK account. Contact Elk Products customer support for more information. This step may be skipped if you are already have a registered ElkLINK account with Elk.

3: Signal Strength Test * MANDATORY *

Always check the cellular signal strength in the proposed mounting location. To do this, apply temporary power to the C1M1 and hold the device close to the proposed mounting location. Monitor the bars of signal on the 7 segment display. We recommend a min. of **3** for reliable service.

CAUTION: Signal strength shown on your smartphone is not a reliable comparison. It displays signal for voice, not data. Voice is not the same as Data!

4: Mounting and Wiring

Turn OFF all power in the Control.

Physically mount the C1M1 in the M1 control enclosure.

Prepare and complete all the wiring connections.

Apply power.

5: Register (Activate) the C1M1 on Telguard

Log in to the Telguard website www.telguardonline.com using your account credentials. Select the option for adding a new subscriber. The required **Serial or MEID** number can be found on a printed label attached to the right side of the unit. Complete all the appropriate information and click register.

6: Register (Authenticate) the C1M1 on ElkLink

Log in to the ElkLINK website www.elklink.com using your account credentials. Select the Device tab and the option for "New". The required **Device MAC** and **Device PIN** numbers can be found on a printed label attached to the right side of the unit. Complete all the appropriate information and click Authenticate.

7: Program the M1 Communications Settings

Setup M1 Telephone #1 for CS reporting over IP. This can be done from Keypad Installer Level programming or the ElkRP PC Software.

8: Test

Test and verify Alarm Signal Transmissions.

Step 1: Establish Telguard dealer account

(This is a one-time event and may be skipped if you are already a registered Telguard Online Customer)

Important: Registration must be completed prior to Installation of any devices. Please setup your Telguard registration from the convenience of your office at least 1 day or more prior to physical installation. Do not wait until you arrive on the customer job site to do this very important step!

To register with Telguard Online go to: www.telguardonline.com

Select the Dealer Sign-up.

Fill out the form in its entirety and click next.

Read and accept the services agreement.

You may also sign up by contacting Telguard Customer Service at 678-945-1651. Within 1 business day you should receive an acknowledgment/approval of your Dealer account form. This acknowledgment will include a Dealer Account Number that should be used for all Telguard registrations.

Step 2: Establish ElkLink dealer

(This is a one-time event and may be skipped if you are already a registered ElkLink Customer)

Important: Please setup your ElkLink registration from the convenience of your office at least 1 day or more prior to physical installation. **Do not wait until you arrive on the customer job site to do this very important step!**

Even though the cellular service for C1M1 is provided by Telguard, you must also establish and maintain a ElkLink account with Elk Products. Your ElkLink account will be used for setup and programming of the Central Station parameters.

To establish an ElkLink account contact Elk Products and ask for Customer or Technical Service. When asked to choose your ElkLink Customer number we recommend using the same number you already use for your Telguard Account. This will help make things simpler and eliminate the need to remember multiple numbers.

The C1M1 can only be activated after all the necessary accounting information has been entered into the customer database in the Telguard Communication Center, and after the Central Station information has been entered into the ElkLink database.

Step 3: Signal Strength Test

Always check the cellular signal strength in the proposed mounting location prior to permanent attachment. This can be done by temporarily powering up the C1M1 and holding it close to the proposed location while monitoring the bars of signal. A minimum of **b2** is suggested. **CAUTION: Do not rely on your smartphone for the signal strength! It displays voice signal strength instead of data signal strength. Voice is not the same as Data!**

3.1. Connect the 12VDC inputs on the C1M1 to a 12VDC power source or 12V battery. Be careful to observe polarity.

3.2. Within 30 seconds the device should boot up and display information on the 7 segment display. This includes bars of service and likely several "E" (error) codes. The error codes are listed on page 2.

The green CELL light should illuminate if sufficient cellular service can be obtained. The bars of service will display as a lower case "b" followed by a number from 0 to 5. More bars are always best, and we recommended choosing a mounting location that provides at least 2 bars or better. This will help ensure reliable cellular service. If the location where the M1 is mounted cannot provide at least 2 bars of service, we recommend relocating everything to a better location OR substituting a good quality remote antenna in place of the dipole antenna that is supplied with the unit. Remote Cellular antennas are available from many sources and can be found in varying lengths of cable.

3.3. Once a suitable mounting location has been found, proceed to the physical installation and wiring of the unit to the M1 Control.

Consider the following prior to permanent mounting:

- Do not mount in an area where persons might regularly come within 20cm (8 inches) of the antenna.
- The best location for a cellular communicator is generally in the highest point of a building or a location with the fewest number of walls between the unit and the closest cell tower.
- Try to avoid mounting the unit near any other electronic devices that might cause interference.
- The included antenna is intended for indoor installations only.
- Always place the unit so that its antenna is perpendicular to the ground, either right side up or upside down. NEVER mount it with the antenna positioned horizontally.

Step 4: Mounting and Connecting to the M1 Control.

C1M1 is designed to be mounted in the top right corner of the M1 Control Enclosure. Be sure to perform a radio signal strength test PRIOR to permanent mounting of the M1 Control or the C1M1.

Mounting

- 4.1. From the inside install the supplied #6 x 3/8 self tapping mounting screw in the hole centered just above the top right knockout of the M1 enclosure. Leave the screw sticking out 1/16". The keyhole slot on the back of the C1M1 will slide onto this screw.
- 4.2. Remove the 1/2" antenna knockout on the top and right side of the enclosure (just above the mounting screw location).
- 4.3. Hold the C1M1 at about a 5 degree angle and thread its antenna up and through the top antenna knockout. While doing so, move the unit to the right until the keyhole slot on the back engages the mounting screw. Slide the unit over and down onto the screw.
- 4.4 The bottom of the C1M1 will straddle a basket handled designed for attachment of wiring with a zip-tie. After all testing has been completed use the included zip-tie to final fix the unit to this basket handle.

Installation must be in accordance with:

- Chapter 2 of the National Fire Alarm Code, ANSI/NFPA 72 and the National Electrical Code, ANSI/NFPA 70.
- UL 1641, Standard for Installation and Classification of Residential Burglar Alarm Systems
- UL 681, Standard for Installation and Classification of Burglar and Holdup Alarm Systems
- UL 827, Standard for Central-Station Alarm Services
- Local Authority Having Jurisdiction
- Wiring methods shall be in accordance with the National Electrical Code, ANSI/NFPA 70.

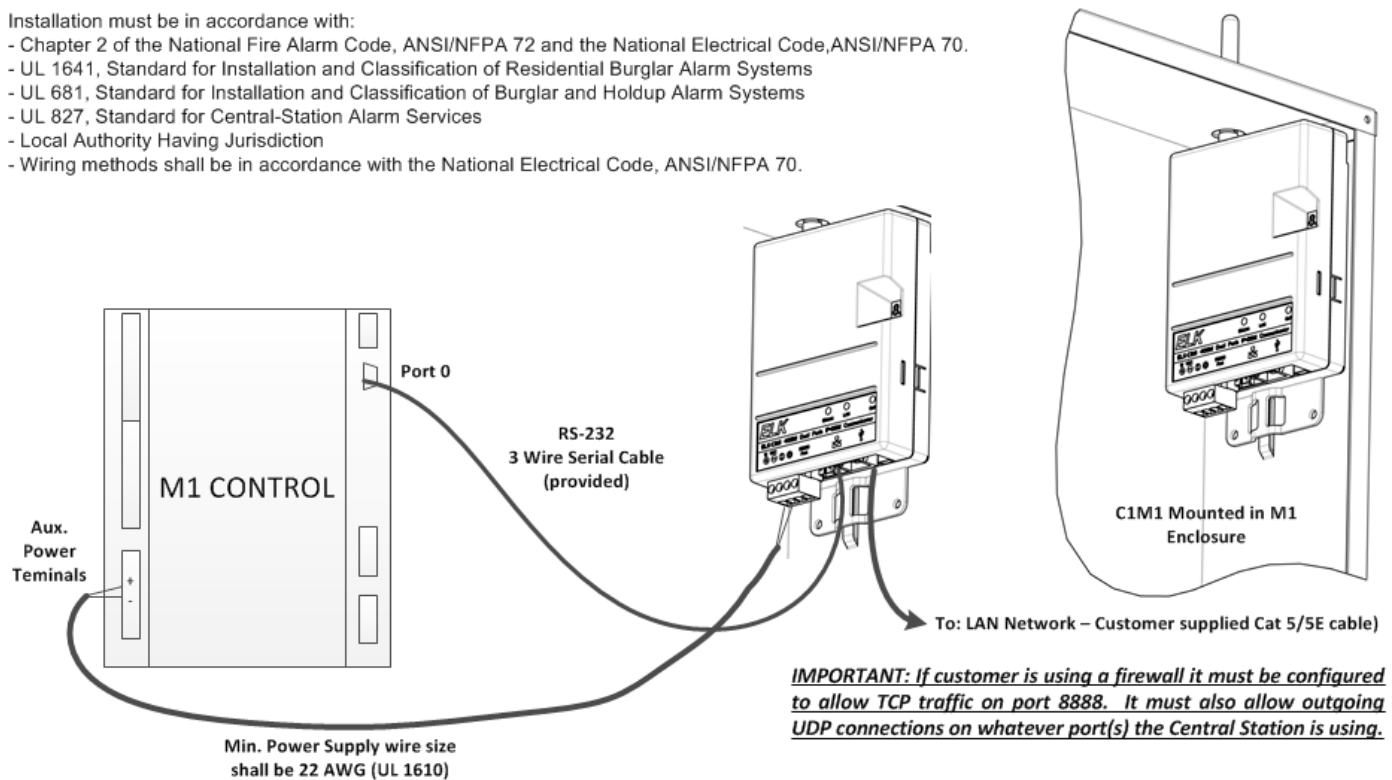

TYPICAL INSTALLATION LAYOUT

Wiring Connections

- 4.4 Make certain the M1 and C1M1 are not powered on while making any connections.
- 4.5. Connect a two-conductor Red/ Black power cable from the Positive and Negative input terminals on the C1M1 to the Positive and Negative output terminals of one of the Auxiliary Power outputs on the M1 Control. Be mindful to observe proper polarity.
- 4.6. Plug the supplied 3-wire serial cable (black cable with white 3-pin connector and 9 pin serial connector) into the C1M1 and then into the main serial port #0 on the upper right edge of the M1 Control.
- 4.7. Connect a Cat5/5E RJ45 terminated LAN cable (not supplied) from the C1M1 to the Customer's LAN switch or router.
- 4.8. Make sure all connections including the screw-on dipole antenna are correct and secure. Turn on the M1 Control power. The C1M1 should power up.
- 4.9. Observe the C1M1 LEDs and the 7 segment display for activity. The unit will immediately attempt to obtain an IPv4 address via DHCP from the customer's LAN router, and display that IP address during the first few minutes after power application.

Example: *A 192.168.0.100*

Step 5: Register (activate) the new Subscriber (customer) Account on the Telguard website

A completed Subscriber registration is required by Telguard to register any new C1M1 units. **Installation Tip:** To help avoid multiple trips to a job site we suggest registering prior to leaving for the job site.

Registration of a new Subscriber should be done Online - Complete the Registration Form at www.telguardonline.com

Telguard Technical Service is open from 8:00 AM – 8:00 PM EST Monday – Friday, 9:00 AM – 5:00 PM EST Saturday and closed during major holidays; registration forms received after hours will be processed by 9:00 AM EST the next business day.

- 5.1. Log in to the Telguard website. www.telguardonline.com
- 5.2. Choose the **Register Subscriber** link on the left side under the Current Dealer Menu.
- 5.3. On this form enter the **Serial Number** printed on the side of the C1M1 which is the Telguard ID for the unit. Note: Units may also be registered by entering the **ICCID Number**.
- 5.4. Choose the **Validate** button. The Subscriber Profile screen should appear once the Serial or MEID number has been successfully validated in the database.

NOTE: You do not need to use the Unit Template options/ screen as this does not apply to the C1M1.

- 5.5. Choose the Subscriber info tab on the Subscriber Profile screen. NOTE: Please make a note of the Subscriber # which is automatically assigned by TelGuard.
- 5.6. Fill out the Subscriber Information page including the name, industry, address, city, state, zip, and country.

For the **Client Account Number** we recommend entering the **Reporting Acct** number that will be transmitted to the Central Monitoring Station. This **Reporting Acct** number must also be entered when registering the C1M1 on the ElkLink website.

The Rate Plan box should automatically be set. Be advised that C1M1 is included in the Telguard Advantage Program (TAP) for companies that participate in that program.

- 5.7. Choose the **REGISTER SUBSCRIBER** button.
- 5.8. The Subscriber # and 10 digit Serial Number will be displayed across the top of the Subscriber Profile screen. Either of these may be used to lookup a C1M1 in the Telguard system.
- 5.9 Choose the **Support tab** and then choose the ElkLink hyperlink icon. This should open and connect to the ElkLink website where final registration will take place.

www.elklink.com

By hitting the Register Subscriber button, the Dealer acknowledges and accepts all Telular Terms and Conditions. Dealer authorizes the immediate activation of service. This is real-time subscriber registration and you should receive a response back after clicking the Register Subscriber button.

Step 6: Register (authenticate) the C1M1 Device on the ElkLink website

6.1. Log in to the ElkLink site using your ElkLink Alarm Company credentials.

IMPORTANT! To register a new C1M1 device your ElkLink login authority level must be: Alarm Company Admin or Alarm Company Reg. An Alarm Company ViewOnly authority cannot add or edit a device, it can only review the settings.

6.3. Choose the **Device** tab. This screen will list any/all devices that are currently activated under your Alarm Company authority.

6.4. To add a New Device click the **+ New** option on left side of the screen.

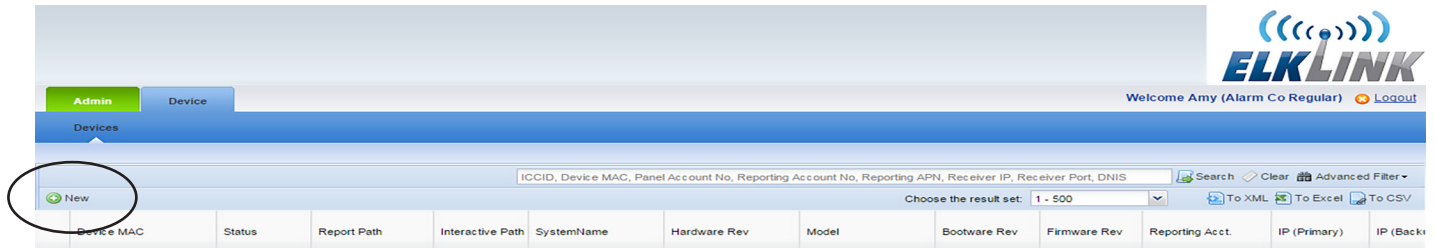

6.5. The Add New Device screen should appear with the Service Provider, Alarm Co Name, Alarm Co Num, and Receiver IP Address/Port fields already completed. These fields are auto-filled from your ElkLink Company Account registration.

Note: The following fields can be changed from this screen: IP Addresses, Ports, and DNIS. To modify the auto-filled values of these please edit your Alarm Company Profile.

6.6. Enter the **Device MAC** and **Device PIN** using the numbers that are printed on the sticker located on the side of the C1M1 unit. Enter a **System Name** to identify your customer.

6.7. Enter the Central Station **Reporting Acct** number which is the account number you want C1M1 to transmit to the Central Monitoring Station. As mentioned earlier, this same number should have been entered for the Client Account Number on the Telguard website.

6.8. The optional **Heartbeat** field enables supervision of the IP reporting path by periodically sending a heartbeat (ping) to the CS Receiver. **IMPORTANT:** Prior to enabling this option you must ask your Central Station if they accept this option. If so they should be able to provide guidance on the time value setting that is approved. **NOTE:** The Heartbeat is never sent over the Cellular reporting path.

6.9. Once all required information has been entered, choose the **Authenticate Device** button. This step validates that Device MAC, and Device PIN numbers are correct for the unit you are wishing to activate.

6.10. Choose **Confirm Activation**. This will initiate communications with the C1M1 device and make it operational.

Add New Device

DEVICE INFO

Service Provider *: Telguard

Alarm Co Name *: SurGard Alarm

Alarm Co Num *: 2856

Device MAC *:

Device PIN *:

System Name *:

Reporting Acct. *:

Receiver must accept SurGard protocol!

Receiver IP (Primary) *: XXX.XXX.XXX.XXX

Receiver IP (Backup): XXX.XXX.XXX.XXX

Receiver Port (Primary) *: 3061

Receiver Port (Backup): 3061

DNIS *: 01234

Heartbeat: 0

Encryption Key:

STEPS

Step 1

Authenticate Device

Step 2

Confirm Activation

Cancel

NOTE: Encryption of the IP communications is a Device option that cannot be programmed from this screen. It can only be programmed by manually editing the Device after it has been activated. The Central Station generally has the responsibility to assign the encryption key, although some may allow you to choose your own. In either case the encryption key must be 32 hexadecimal digits and must be programmed by manually editing the device.

Step 7: Program the M1 for IP Communications via the C1M1

Setting up and programming the M1 parameters necessary for communications using the C1M1 may be done from the Keypad Installer Level programming or from the ElkRP † Programming Software.

7.1. M1 Keypad Installer Level Programming

From the M1 Keypad enter the Installer Level Programming mode by pressing ELK, 9, RIGHT Arrow, and then entering the Installer Programming code. Navigate to Menu 08, Telephone Account Setup and press the RIGHT arrow key to select. The first screen shows the name currently assigned for Tel #1. A customized name is not required. Use the DOWN or UP arrow keys to scroll and view each menu option. Press the RIGHT arrow key to select and program the desired option.

Telephone #1 - This is the one and only telephone number that MUST be programmed in order to use the C1M1. Program each option as follows:

- 7.1.1. Program option 01 (Format) as "06 = Ethernet". This is required for M1 IP communications.
- 7.1.2. Program option 02 (Priority) as "0 = Always Report".
- 7.1.3. Skip option 03 (Num) but set option 04 (Dial Attempts) to at least 01.
- 7.1.4. Program the Areas (partitions) to be identified at the Central Station by entering a non-zero number (e.g. 009999, 000001, etc) into the respective Acct code locations (Options 05 thru 12, Acct # for Areas 1 - 8). The C1M1 will not report an area if the acct number is blank (000000). NOTE: The actual Account Number which identifies the M1 Customer to the Central Station is programmed and stored in the C1M1 via the ElkLink web portal. C1M1 reports that single Acct number and includes extended information that identifies the area (partition) to the Central Station.
- 7.1.5. Program option 13 as "Yes" if you wish to enable reporting of Zone Alarms, Zone Restorals, and Zone unbypasses.
- 7.1.6. Program option 14 as "Yes" if you wish to enable reporting of Zone Bypasses.
- 7.1.7. Program option 15 as "Yes" if you wish to enable reporting of Zone Troubles.
- 7.1.8. Program option 16 as "Yes" if you wish to enable reporting of User Openings and Closings.
- 7.1.9. Program option 17 as "Yes" if you wish to enable reporting of Global System (AC, Low Battery, etc.) events.

NOTE: Telephone or "dialed" number is the legacy method used by M1 for communicating alarms. Of the available 8 telephone numbers in the M1 only Telephone #1 is required as part of the process for enabling C1M1 Cellular and IP communications. The other 7 numbers can still be used for digital or voice dialing if the client still has a working POTS (plain old telephone) line. In that case Telephone #2 could be setup and utilized as a digital dialer backup for the C1M1 should it ever be unsuccessful in reaching the Central Station. Keep in mind that since C1M1 is a Dual Path Communicator, it backs up itself using one of its two different communications pathways (IP and Cellular).

Reporting Codes - Menus 09, 10, 11, 12, and 13. Each of these Menus lists reporting codes grouped by category.

- 7.1.10. Program each reporting code (Zone, User, System Event, etc.) that needs to be reported by entering a non-zero value (e.g. 01, 99, etc.) Reporting codes with a value of 00 will NOT be reported.

7.2. ElkRP Programming Software †

Download and install the ElkRP PC Programming Software from the Elk Products website. www.elkproducts.com Connect to the M1 Control and program all necessary communications options. It will be necessary to create a new (blank) client M1 account in ElkRP unless you have previously used ElkRP to program this M1 Control.

With the C1M1 connected to the M1 Control there are two ways to connect ElkRP with the M1. #1 is for a Local connect, #2 is for Remote connect.

- 1) Local Connect - Utilizes a USB (Serial A to USB Mini B) cable from the PC to the USB port on C1M1. In ElkRP select On-site Local from the connection dropdown then select: PC USB Port TO Device USB (if available). Almost all modern computers now have a USB port and this method does not disrupt or interfere with the C1M1 connection to M1 serial Port 0.
- 2) Remote connect - This utilizes Elk's Cloud Proxy server. In ElkRP select Network Proxy from the connection dropdown. A login window will open. Enter your ElkLink login credentials. You will be given an option to save these credentials in the account database for future use.

Older "legacy" ElkRP methods that are still supported:

- A) Local IP connect from the PC via the customer's LAN to the C1M1 IP "LAN" port. ** This requires an option to be set in the C1M1 that allows inbound IP connections via either secure or non-secure ports.
- B) Local RS232 from the PC to the M1 serial Port 0. Unfortunately this requires that the C1M1 be disconnected from Port 0 which will disrupt and interfere for the duration of the ElkRP programming sessions and while the device remains disconnected.

† Not evaluated by UL

Telephone #1 - This is the one and only telephone number that MUST be programmed in order to use the C1M1. Use the ElkRP Software † to program each option as follows:

- 7.2.1. Open/create the account file for the M1 Control and connect ElkRP using one of the methods mentioned in the box previous. With the account open select **Telephones** from the left hand column. If Telephone #1 does not already exist, choose New (or right click the mouse button) and add it. If Telephone #1 already exists then select edit its settings.
- 7.2.2. Program the Priority for Telephone #1 as: "Always Report".
- 7.2.3. There is no need to program a Name for Telephone #1. This is optional and may be skipped.
- 7.2.4. Program the Format for Telephone #1 as: IP (6)
- 7.2.5. There is no need to program the Number to Dial but the Dial Attempts should be set to at least 01.
- 7.2.6. For each of the Reporting events (Alarms, Users, Globals, etc.) place a check mark in the adjacent box of those you wish to have the C1M1 report.
- 7.2.7. ElkRP will present a list of 8 checkboxes for selecting the Areas (partitions) to be reported to the Central Station. The C1M1 will not report an area if the acct number box is not checked. NOTE: The actual Account Number which identifies the M1 Customer to the Central Station is programmed and stored in the C1M1 via the ElkLink web portal. C1M1 reports that single Acct number and includes extended information that identifies the area (partition) to the Central Station.
- 7.2.8. If you wish to setup Telephone #2 as a digital dialer backup to Telephone #1, add or edit Telephone #2 and program it as type: "Backup." Telephone #1 will be the primary means of communications and Telephone #2 will only be used as digital dialer backup should Telephone #1 (C1M1) be unsuccessful. Dual reporting (to both) may also be selected by configuring the Type for both numbers as: "Always Report." Be aware that some Central Stations may charge additional fees for dual reporting.
- 7.2.9. Select Communicator from the left hand column and review each of the different Reporting Codes (RCs) by category. Program each reporting code (Zone, User, System Event, etc.) that needs to be reported by entering a non-zero value (e.g. 01, 99, etc.). Reporting codes with a value of 00 will NOT be reported.
- 7.2.10. Select the Send to Control button to program these settings. VERY IMPORTANT! ElkRP must be connected to the M1 Control in order to do this.

C.S. Telephone: 1
Type: 0 = Always report to this number

Name: XYZ Central Stat
Number to dial:
Reporting format: 6 = IP
Dialing attempts: 1

Report the following using this number

- Area events, alarms, restorals, and unbypasses
- Zone bypasses
- Zone troubles
- User events (opens/closings)
- Global system events

Select Areas

Select the areas allowed to report to this Central Station

- Area 1
- Area 2
- Area 3
- Area 4
- Area 5
- Area 6
- Area 7
- Area 8

Send to Control

M1XEP Setup

Central Station data is entered on the M1XEP Setup window.

ATTENTION: ElkRP displays a setup button for the Elk-M1XEP however there is no need to select this or attempt to setup anything from here. The setup for the C1M1 (IP address, Acct number, Port, DNIS, etc.) is managed through the ElkLink portal and obtained from there by the C1M1.

Step 8: Test and Verify Alarm Signal Transmissions via Cellular, IP, or both

Trip several alarms on the M1 Control and verify that the central station receives them.

If you are having problems getting reliable alarm signal transmissions, additional adjustments may be necessary.

- Recheck signal strength. You need at least 2 bars of service [**b 2**] to be assured of reliable service.
- Check antenna connector and make sure it is screwed on and seated correctly.

This should complete the Installation and Programming of the C1M1 Communicator. The C1M1 should now be operational.

AGENCY COMPLIANCE STATEMENTS

FCC AND IC COMPLIANCE STATEMENT:

Device Uses Approved Radio: NL-SW-LTE-GELS3

ELKC1M1 LTEV ElkCommBd Communicator Contains FCC ID: QIPELS31-V (LTE Radio Module)

This device complies with Part 15 of the FCC Rules. Operation is subject to the following two conditions: (1) This device may not cause harmful interferences, and (2) this device must accept any interference received, including interference that may cause undesired operation.

NOTICE: Any change or modification to this equipment not expressly approved by Elk Products Inc. may void the FCC authorization to operate this equipment.

This equipment complies with the FCC radiation exposure limits set forth in an uncontrolled environment.

This equipment should be installed and operated with minimum distance 20cm between the equipment and the user's body.

NOTICE: This equipment has been tested and found to comply with the limits for a Class B digital device, pursuant to Part 15 of the FCC Rules. These limits are designed to provide reasonable protection against harmful interference in a residential installation. This equipment generates, uses and can radiate radio frequency energy and, if not installed and used in accordance with the instructions, may cause harmful interference to radio communications. However, there is no guarantee that interference will not occur in a particular installation. If this equipment does cause harmful interference to radio or television reception, which can be determined by turning the equipment off and on, the user is encouraged to try to correct the interference by one or more of the following measures:

- Reorient or relocate the receiving antenna.
- Increase the separation between the equipment and receiver.
- Connect the equipment into an outlet on a circuit different from that to which the receiver is connected.
- Consult the dealer or an experienced radio/TV technician for help.

FIPS 197 COMPLIANCE STATEMENT:

The ELK-C1M1 LTEV ElkCommBd Communicator device is compliant with FIPS 197. It incorporates a Freescale Kinetis with mmCAU and implements the Elk Crypto Library using AES 128, 192, and 256 encryption standards for encrypted line security. The C1M1 LTEV has been validated by NIST under the requirements of FIPS 197, Advanced Encryption Standard. Elk received FIPS 197 Validation Certificate #3352 on May 8, 2015.

Further information about this may be obtained from:

<http://csrc.nist.gov/groups/STM/cavp/documents/aes/aesval.html>

C1M1 NETWORK (Port) REQUIREMENTS: (Disregard when using C1M1 in cellular only mode)

It is not necessary to forward any inbound ports in your customer's router because C1M1 it initiates all network connections as OUTBOUND from the customer premises. Customers who utilize a firewall to block ports, however, may need to adjust their firewall to allow OUTBOUND connections on specific ports needed by C1M1.

Ports 3061 and 3071 must be opened to OUTBOUND UDP connections. C1M1 uses these ports to communicate with the Central Station IP Receiver(s). **IMPORTANT!** If your Central Station is employing different ports on their IP Receiver(s), then be sure that the matching appropriate ports are programmed and opened in the firewall for OUTBOUND UDP connections.

Port 8888 - This port must be opened to OUTBOUND TCP connections. C1M1 uses this port to communicate with the ElkLink backend server, where the CS reporting parameters and general setup are stored and managed. If customer chooses to use the free remote app, ElkLink Mobile, this same port also facilitates that connectivity. The ElkLink Mobile connectivity may be disabled, however, this port must still be opened or else the C1M1 will not be able to receive parameter changes.

Port 8899 may need to be opened to OUTBOUND TCP connections but only if the customer wishes to use ElkRP Remote Programming or one of the third party mobile apps: eKeypad or M1TouchPro. C1M1 uses this port reach the ElkLink "proxy" server that facilitates the proxy connectivity of these programs. Third part remote control and ElkRP Remote Programming over network will be blocked if this port is not opened.

To test for outbound allowed ports use this tool: <http://portquiz.net:xxxx> NOTE: Substitute the xxxx with the port you wish to test.

Limited Warranty

The ELKC1M1 LTEV ElkCommBd Communicator is warranted to be free from defects and workmanship for a period of 2 years from date of manufacture. Refer to Elk's website for full warranty statement and details.

NOTE: ELK PRODUCTS IS NOT RESPONSIBLE FOR ANY CHANGES OR MODIFICATIONS NOT EXPRESSLY APPROVED BY THE PARTY RESPONSIBLE FOR COMPLIANCE. SUCH MODIFICATIONS COULD VOID THE USER'S AUTHORITY TO OPERATE THE EQUIPMENT.



PO Box 100 3266 US Hwy 70 West
Hildebran, NC 28637
828-397-4200 828-397-4415 Fax <http://www.elkproducts.com>

Printed in USA
L672 Rev. A 7/2/18