



PRODUCT CODES

GJD500 D-TECT Laser

UNIQUE FEATURES

Covert operation: the LED display can be switched off with the remote control

4 adjustable sensing curtains to provide alarm & pre-alarm warning

High immunity to environmental interference using dedicated time of flight software

END USER BENEFITS

Capacity to detect or ignore objects with a remission factor down to 2%

Discreet design with optional black or white housing

IP65 rated, indoor and outdoor applications

Extremely reliable detection

D-TECT Laser

The D-TECT Laser is an extremely reliable security device designed to create virtual (invisible) curtains, walls and surveillance security zones. The Laser is programmable to within 10cm (4") and operates with the highest levels of precision for accurate and reliable intrusion detection.

Applications:

- Create virtual walls or ceilings.
- Window, door and roof protection.
- Perimeter protection and intrusion detection.
- Securing open sites.
- Monitoring pedestrian and vehicle access points.

EASE OF INSTALLATION

- 3 visible red LASER beams can be activated to align the detection surface and adjust the tilt and rotation angles
- Teach-in function: self-learning of both environment and background through an automatic adjustment of the detection planes
- Remote control to easily set the adjustable parameters

DIMENSIONS

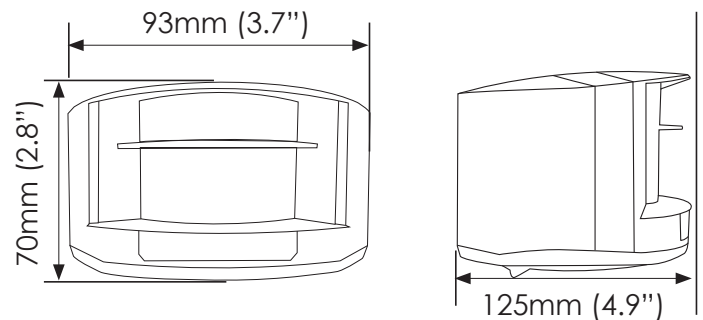

SECTORS



RESIDENTIAL



COMMERCIAL



INDUSTRIAL



BORDERS



MILITARY BASES



PORTS



POWER PLANTS



HERITAGE



AIRPORTS



PRISONS

TECHNICAL SPECIFICATIONS

ACCESSORIES

GJD501	Laser Programmer
GJD511	Laser Bracket
GJD513	D-TECT Laser Spot Finder



D-TECT LASER PROGRAMMER

The user friendly programmer allows all settings and parameters to be easily set and adjusted.

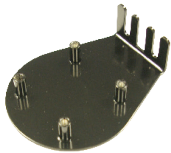

D-TECT LASER BRACKET

This bracket is required when fitting the laser 'end on' to a wall or post.



D-TECT LASER SPOT FINDER

The Spotfinder is a set up too that enables the engineer to locate the precise position of the laser curtains.

TECHNOLOGY	Laser scanner, time-of-flight measurement
DETECTION MODE	Movement and presence
MAX. DETECTION RANGE	GJD500: 82ft x 82ft (25m x 25m)
ANGULAR RESOLUTION	0.3516*
REMISSION FACTOR	>2%
TYP. MIN.TARGET SIZE	0.06in @ 9.84ft / 1.37in @ 16.4ft / 2.75in @ 32.8ft / 6.88in @ 82ft (2.1cm @ 3m / 3.5cm @ 5m / 7cm @ 10m / 17.5cm @ 25m) (in proportion to object distance)
EMISSION CHARACTERISTICS IR LASER	Wavelength 905 nm; max. output pulse power 75W (Class 1)
RED VISIBLE LASER	Wavelength 650 nm; max. output CW power 3mW (Class 3R)
SUPPLY VOLTAGE	10-35V DC @ sensor terminal
CABLE LENGTH	32.8ft (10m)
POWER CONSUMPTION	< 5 W
PEAK CURRENT AT POWER ON:	1.8 A (max. 80 ms @ 35 V)
RESPONSE TIME	Typ. 20 ms; max. 80 ms
OUTPUT MAX SWITCHING VOLTAGE MAX SWITCHING CURRENT	2 electronic relays (galvanic isolated – polarity free) 5V DC / 24V AC 80mA (resistive)
LED SIGNALS	1 blue LED: power-on status, 1 orange LED: error status, 2 bicoloured LED's: detection/output status (green: no detection, red: detection.) The LED's can be switched off by remote control
DIMENSIONS	4.92in x 3.66in x 2.75in (125mm x 93 mm x 70mm) (mounting bracket + 0.55in (14 mm)
MATERIAL	PC/ASA (colour: black or white)
ROTATION ANGLES ON BRACKET	-5° to +5° (lockable)
TILT ANGLES ON BRACKET	-3° to +3°
PROTECTION DEGREE	IP65 (avoid direct exposure to high pressure cleaning)
TEMPERATURE RANGE	-30°C to +60°C if powered / -10°C to +60°C unpowered
HUMIDITY	0-95% non-condensing
VIBRATIONS	< 2 G
NORM CONFORMITY	2006/95/EC: LVD; 2002/95/EC: RoHS; 2004/108/EC: EMC; EN 60529:2001, IEC 60825-1:2007 Laser Class 1 & 3R; EN 61000-6-2:2005 EMC – Industrial level; EN 61000-6-3:2006 EMC – Commercial level

BEAM PATTERNS

VIRTUAL WALL

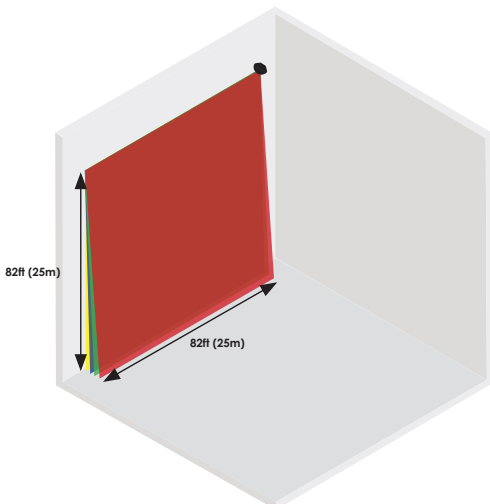

VIRTUAL CEILING

