

# 1-Port 10/100TX over Coaxial Long Reach Ethernet Extender



## Easy Connection to Ethernet over Coaxial Extender

To fulfill the needs of long distance Ethernet over Coaxial applications, PLANET Technology offers a new-generation Ethernet over Coaxial Converter, LRE-101C. It features 1 10/100 BASE-T RJ45 port and 1 BNC female connector with a compact-sized metal housing, making the placement of the unit convenient. Working well with a pervasive coaxial network, the LRE-101C provides a total duplex data rate of 100Mbps which can extend a maximum distance of up to 2km and expand a small network by using the point-to-multi-point topology. It is ideal for extending the distance and signal conversion by transmitting the Ethernet data from the coaxial cable to another 100-meter UTP cable for any type of IP network device such as HD IP camera, wireless access point, NVR and digital signage.



## IP Ethernet over Long Distance Existing Coaxial Cables

PLANET LRE-101C is a **Long Reach Ethernet (LRE)** solution which provides a quick replacement and smooth migration solution from the existing analog system to a full digital system. A normal UTP cable can only be extended to up to 100 meters, but with the LRE-101C, the distance for Ethernet networking can be extended to up to **2000 meters (6561ft.)**, which is ideal for the following network applications:

- Long-distance IP network devices
- IP digital signage
- Cable TV to IPTV
- Distance video education
- Electronic billboards
- Other applications

## Product Features

- 10/100Mbps RJ45 port, auto negotiation and half/full duplex mode
- Uses existing RG59/RG6 coaxial cable
- Long distance Ethernet data transmission up to 2km
- Master/Slave mode selectable via DIP switch
- Maximum 1522 bytes packet size, IEEE 802.1Q VLAN tag transparency
- Advantage of minimum installation time (Simply by Plug-and-Play)
- Supports extensive LED indicators for network diagnosis
- Compact in size and easy to install
- Works with PLANET media converter chassis (MC-700/MC-1500/ MC-1500R/MC-1500R48)

If you have coaxial cable in your existing environment, you can install a pair of the LRE-101C very simply without the need to build additional network wires, thus saving costs for network construction.

*Easy and Flexible Installation*

The LRE-101C offers two operation modes, the client-side “Slave” and central-side “Master”, making any network applications easy and flexible. The “Slave” or “Master” mode can be adjusted by using the built-in DIP switch. For point-to-point connection, one LRE-101C in “Slave” mode and the other one in “Master” mode must be set up as a pair of converters to perform the connection. This enables the administrator to efficiently manage the network over UTP cable, making long-distance transmission better.



*Daisy-chaining Multiple Nodes*

PLANET LRE-101C will give users the flexibility to expand a small area network with **BNC T-connector** for sharing **four nodes per port** when needed.

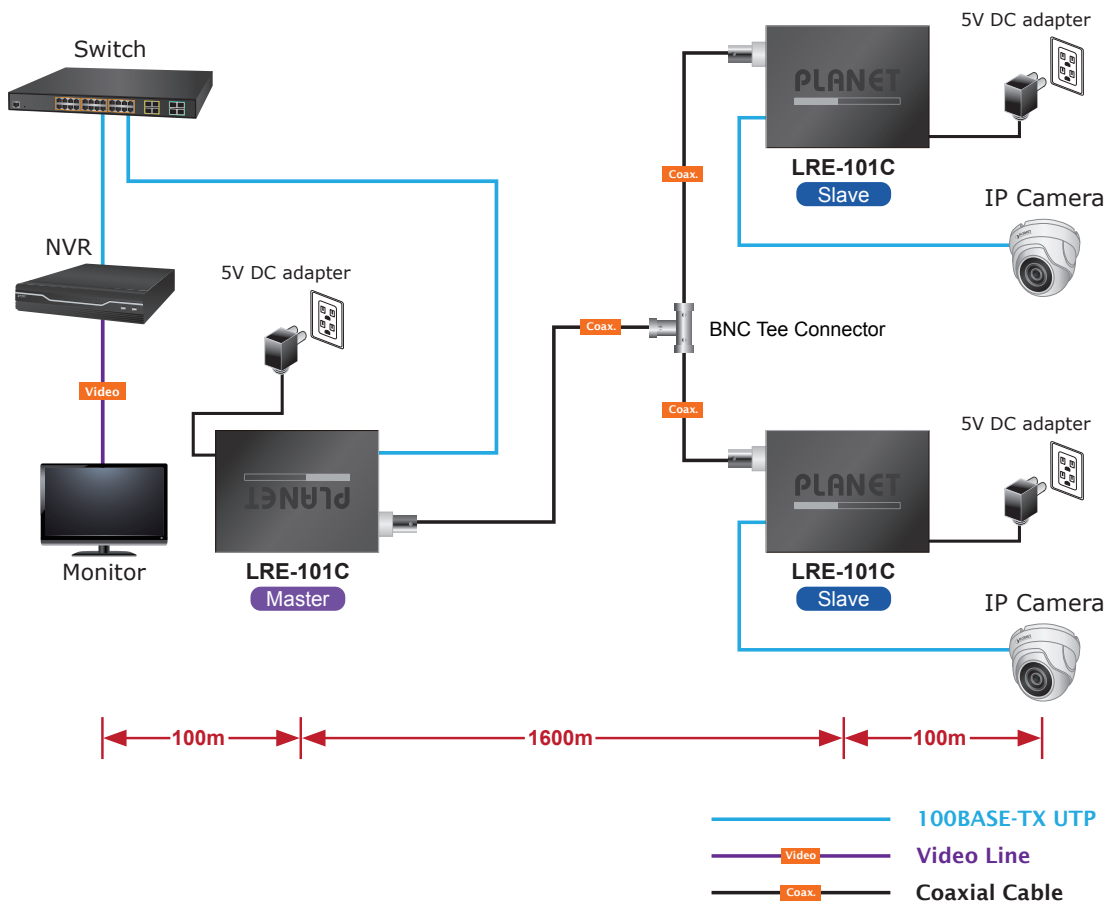

*Low Power Consumption*

The LRE-101C has a low power consumption of only **1.5 watts** when in full operation.

*Easy Chassis Installation*

The LRE-101C Long Reach Ethernet Extender can be used as a stand-alone unit or as a slide-in module to the PLANET Media Converter Chassis (**MC-700** and **MC-1500** chassis series). The media chassis can assist in providing DC power to LRE-101C. It can be **DIN-rail** or **wall mounted** for efficient use of cabinet space.

### Optional installation method



Media Chassis Installation



DIN-rail Installation



Wall-mount Installation

### Applications

*Point-to-Point Application -- LAN to LAN Connection*

One set of the LRE-101C Extender could be used to link two local area networks that are located in different places. Through the coaxial cable, it could set up a 100Mbps backbone, but one must be **Master (CO mode)** and the other one is **Slave (CPE mode)**.

### Point to Point Application

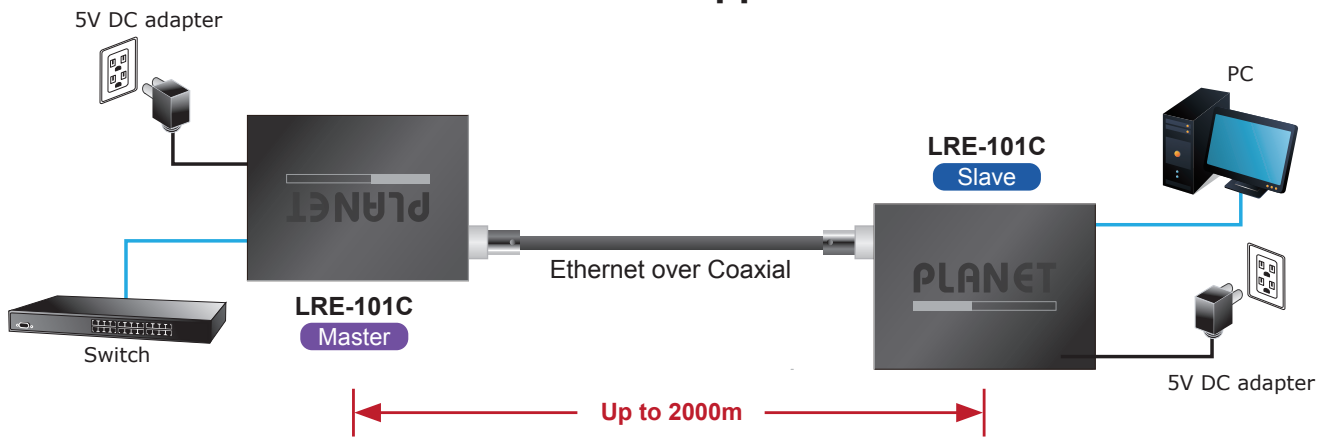

*Community/Campus Surveillance and Security over IP*

To take advantage of digital surveillance system and keep the benefits of coaxial cable, the LRE-101C helps the communities, campuses and enterprises to upgrade analog camera system to IP camera surveillance without using additional new wires. The LRE-101C is a switching architecture with one RJ45 port and one BNC Ethernet over Coaxial port. Just plug in the UTP cable of IP camera to Ethernet port and the existing coaxial cable to the BNC connector to easily deploy and extend the distance with signal conversion by transmitting the Ethernet data from the standard coaxial cable.

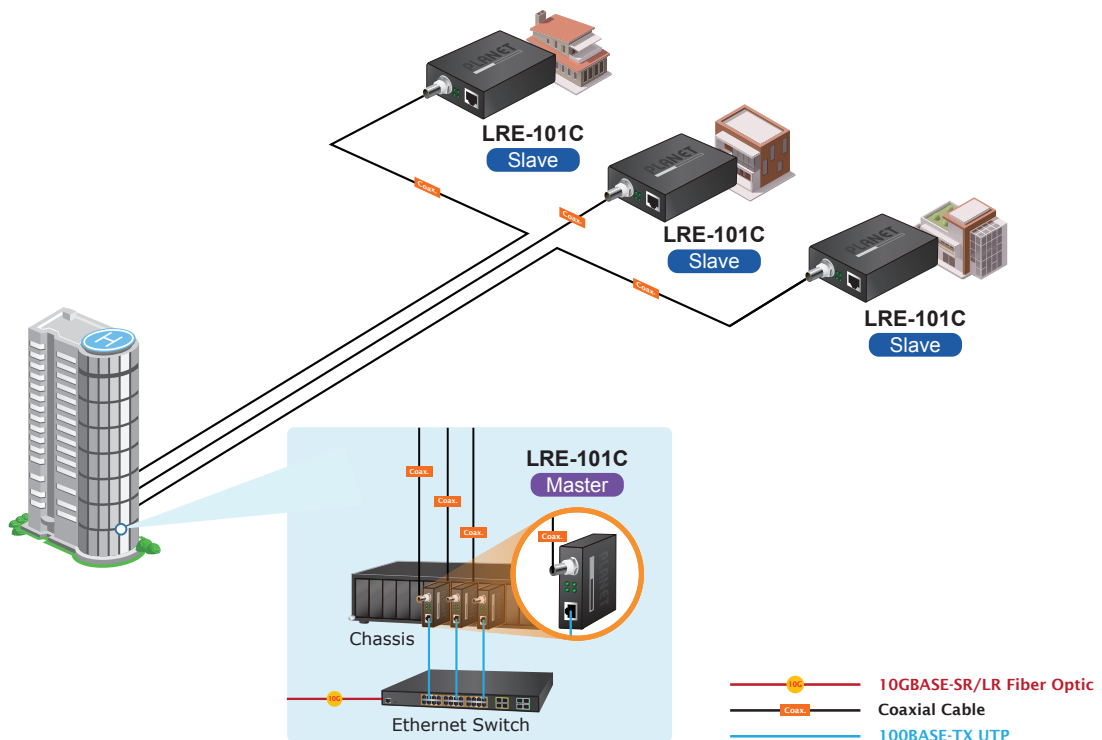
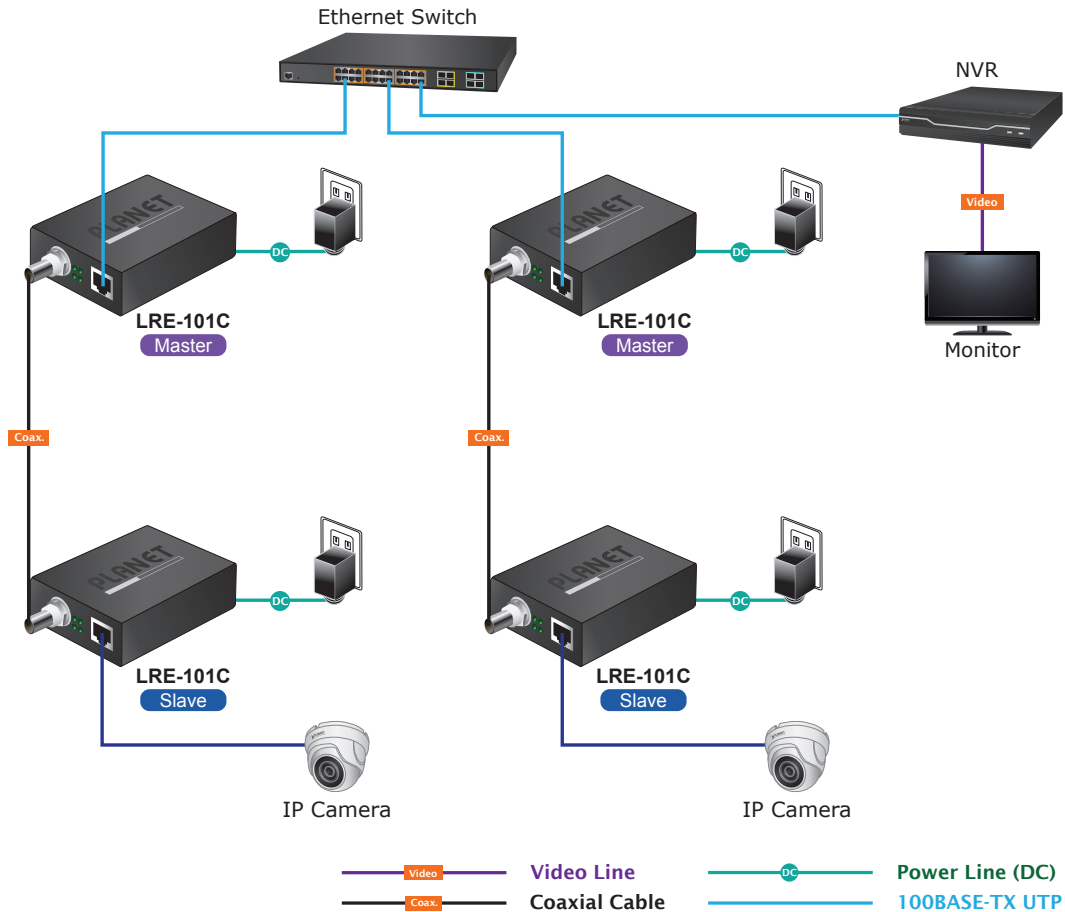

## Specifications

Product	LRE-101C		
<b>Hardware Specifications</b>			
LAN Ethernet interface	1 10/100BASE-TX RJ45 Copper port, auto-negotiation / auto-MDI/MDI-X		
	Cabling	Cat5e UTP or above	
	Maximum Distance	100 meters	
	Maximum Frame Size	1522 bytes	
Long Reach Interface	1 BNC female Ethernet over Coaxial		
	Cabling	Coaxial cable: 75 ohm RG-6/U cable, less than 12Ω/1000 ft. RG-59/U cable, less than 30Ω/1000 ft.	
	Maximum Distance	Max. 2000 with data transmission (6,561ft.)	
	Long Reach Ethernet Standard	IEEE 1901	
	Modulation Type	Wavelet-OFDM	
	Security	128-bit AES encryption	
	Frequency Band	2~28MHz	
	Performance*	Distance	Data Rate (Upstream/Downstream)
		200m	94/94Mbps
		600m	94/94Mbps
		800m	88/87Mbps
		1000m	76/73Mbps
		1200m	61/58Mbps
1400m		45/43Mbps	
1600m		35/33Mbps	
Functionality	DIP Switch	Select Master or Slave mode	
	Dimensions (W x D x H)	97 x 70.3 x 26 mm	
	Weight	194g	
	Housing	Metal	
Power Requirement	5V DC, 2A external power		
LED Indicators	Power: <b>Green</b> LAN: <b>Green</b> , 10/100Mbps LNK/ACT Long Reach: <b>Green</b> , LNK Master: <b>Green</b>		
<b>Standards Conformance</b>			
Standards Compliance	IEEE 802.3/ 802.3u Ethernet standard compliant IEEE 802.3x Full-duplex flow control IEEE 802.1q Tag VLAN Transparent, Multicast pass-through		
Regulatory Compliance	FCC Part 15 Class A, CE		
<b>Environment</b>			
Temperature	Operating: 0~50 degrees C Storage: -10~70 degrees C		
Humidity	Operating: 5~95% (non-condensing) Storage: 5~95% (non-condensing)		

## Dimensions

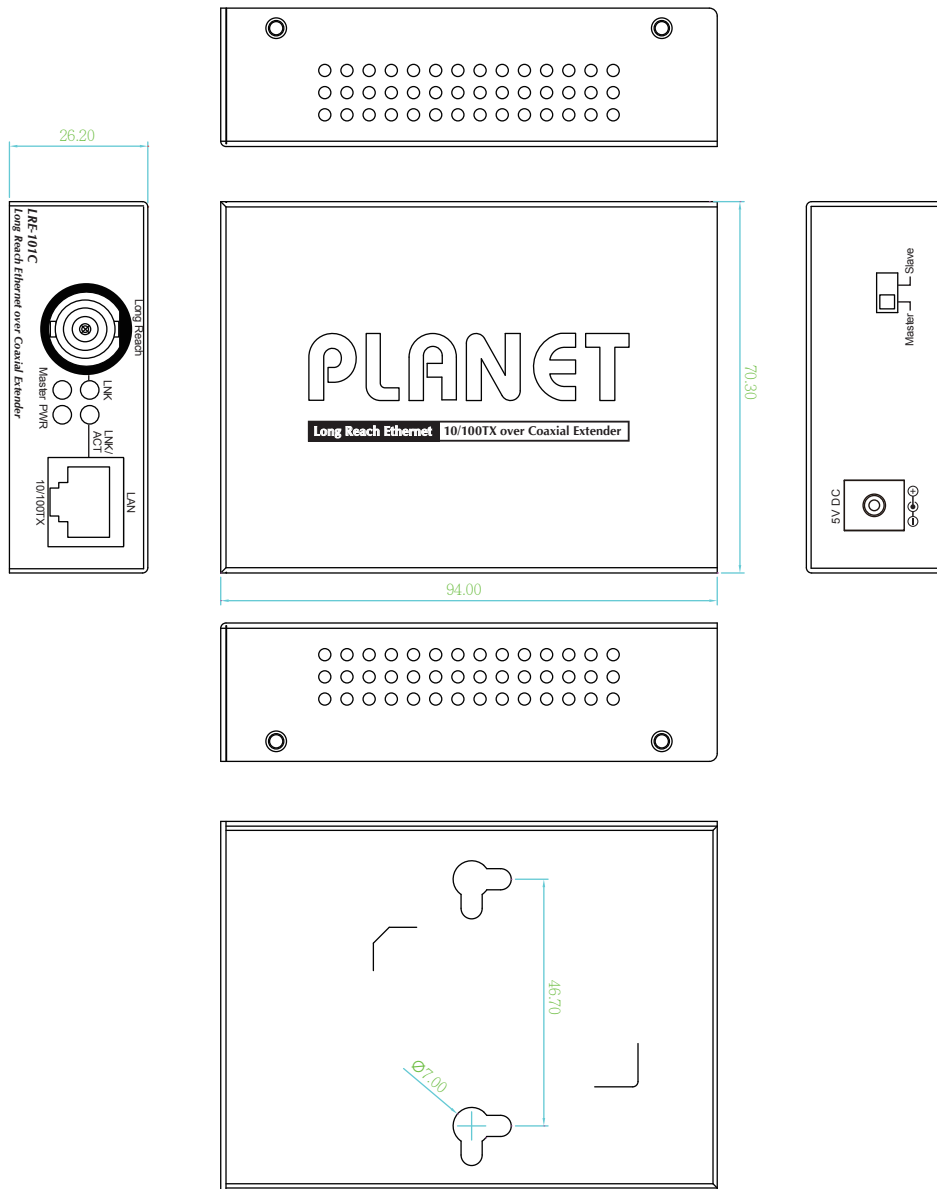

Unit: mm

## Ordering Information

LRE-101C	1-Port 10/100TX over Coaxial Long Reach Ethernet Extender
----------	---

## Related Products

LRE-101	1-Port 10/100TX over UTP Long Reach Ethernet Extender
MC-1500	15-Slot Media Converter Chassis
MC-1500R	15-Slot Media Converter Chassis (AC Power)
MC-1500R48	15-Slot Media Converter Chassis (DC Power)
MC-700	7-Slot Media Converter Chassis

### PLANET Technology Corporation

11F., No.96, Minquan Rd., Xindian Dist., New Taipei City 231, Taiwan (R.O.C.)

Tel: 886-2-2219-9518

Email: sales@planet.com.tw

Fax: 886-2-2219-9528

www.planet.com.tw



PLANET reserves the right to change specifications without prior notice. All brand names and trademarks are property of their respective owners. Copyright © 2022 PLANET Technology Corp. All rights reserved.

LRE-101C