

Industrial 4-port Coax + 2-port 10/100/1000T + 2-port 100/1000X SFP Long Reach PoE over Coaxial Managed Switch



PLANET Long Reach PoE Solution enables all enterprises and network service providers to set up an IP infrastructure in a remote location where 802.3af/at PoE compliant powered devices can receive both data and power via PLANET switches, and PLANET LRP extenders and injectors over a long distance but not limited to the normal 100 meters.

Intelligent Long Reach PoE Switch on Coaxial-based Network

PLANET LRP-422CST, a brand-new Multi-channel Long Reach PoE Switch, features an extended Ethernet and PoE networking of up to 1 kilometer over the existing coaxial cables going to multiple PoE compliant devices. It provides IPv6/IPv4 dual stack management and built-in L2/L4 Gigabit Switching engine along with 4 BNC ports with Long Reach PoE Injector function, 2 Gigabit copper ports and 2 extra 100/1000BASE-X SFP fiber slots. Each of the BNC ports provides 36 watts of power with a total power budget of up to 150 watts. As an advanced PoE switch, the LRP-422CST features intelligent PoE functions to improve the availability of critical applications. It provides a quick, safe and cost-effective PoE network solution to upgrading the existing coaxial cable infrastructure from the analog system to the HD IP surveillance system.



Physical Port

- 4 100Mbps BNC female ports with Long Reach PoE Injector function
- 2 10/100/1000BASE-T Gigabit RJ45 copper ports
- 2 100/1000BASE-X mini-GBIC/SFP slots
- RJ45 console interface for switch basic management and setup

Long Reach Power over Ethernet

- Supports PoE power up to 36 watts for each PoE port
- Remote power feeding up to 1 kilometer with 5C2V/RG6 75Ω coaxial cable
- Long Reach PoE Management
 - Total Long Reach PoE power budget control
 - Per port Long Reach PoE function enable/disable
 - Long Reach PoE port power feeding priority
 - Per Long Reach PoE port power limitation
 - Long Reach PD alive check
 - Long Reach PoE schedule

Industrial Case/Installation

- IP30 aluminum case protection
- DIN-rail and wall-mount design
- Redundant Power Design
 - 48 to 56V DC, redundant power with polarity reverse protect function
- Supports EFT protection for 6000V DC power and 6000V DC Ethernet ESD protection
- -20 to 75 degrees C operating temperature

Layer 2 Features

- Prevents packet loss with back pressure (half-duplex) and IEEE 802.3x pause frame flow control (full-duplex)
- High performance Store and Forward architecture, broadcast storm control and runt/CRC filtering that eliminates erroneous packets to optimize the network bandwidth
- Supports VLAN
 - IEEE 802.1Q tagged VLAN
 - Provider Bridging (VLAN Q-in-Q, IEEE 802.1ad) support
 - Protocol VLAN
 - Voice VLAN
 - Private VLAN
 - Management VLAN
 - GVRP
- Supports Spanning Tree Protocol
 - STP (Spanning Tree Protocol)
 - RSTP (Rapid Spanning Tree Protocol)
 - MSTP (Multiple Spanning Tree Protocol)
 - STP BPDU Guard, BPDU Filtering and BPDU Forwarding
- Supports Link Aggregation
 - IEEE 802.3ad Link Aggregation Control Protocol (LACP)
 - Cisco ether-channel (static trunk)
 - Maximum 4 trunk groups, up to 4 ports per trunk group

Environmentally Hardened Design

With IP30 aluminum industrial case protection, the LRP-422CST provides a high level of immunity against electromagnetic interference and heavy electrical surges which are usually found on plant floors or in curb-side traffic control cabinets. It also possesses an integrated power supply source with wide range of voltages (48 to 56V DC) for worldwide high availability applications requiring dual or backup power inputs. Being able to operate under the temperature range from -20 to 75 degrees C, the LRP-422CST can be placed in almost any difficult environment.

Multi-channel Long Reach Power over Ethernet

To support the enterprises in easily building a multi-channel and centrally-controlled Long Reach PoE system, the LRP-422CST works with the Long Reach PoE Extenders, LRP-101CE, via its 4 BNC ports being the Long Reach PoE injectors for all connected LRP Extenders. Each of the BNC ports features long range data and power transmission for distance up to 1,000m (3,280ft) over coaxial cable to the LRP Extender, and another 100m over Ethernet cable to remote PoE IP camera, PoE wireless AP or access control systems complied with 802.3af/at PoE.

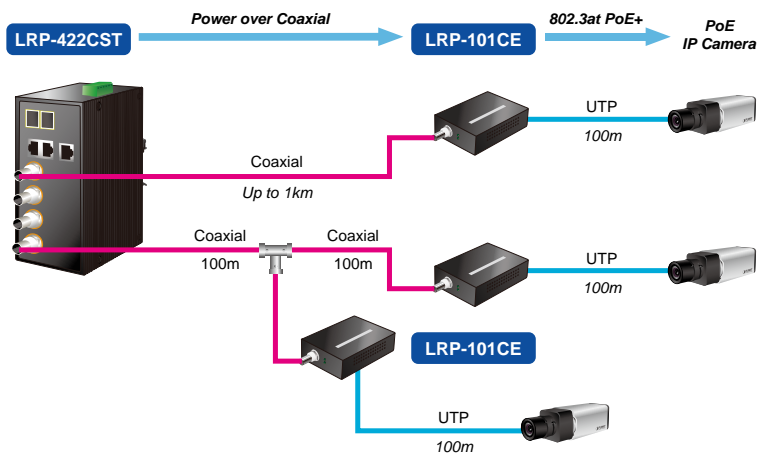

Centralized Power Management

With the centrally-managed 150-watt PoE budget, the LRP-422CST eliminates the need for an additional remote site power while allowing a single power source to provide power to both LRP extenders and the PoE powered devices at long range. The Long Reach PoE capabilities provided help to reduce installation time and deployment costs for network devices as a result of freeing from restrictions of power outlet locations.

Daisy-chaining Multiple Nodes

PLANET Long Reach PoE solution can easily build a power system for centrally-controlled IP cameras in a high availability network infrastructure. It gives users the flexibility to expand small area network with BNC T-connector for sharing four nodes per port when needed, making the LRP-422CST with 4 BNC Long Reach PoE Ports an ideal support for up to 16 PoE powered devices.

- Provides port mirror (many-to-1)
- Loop protection to avoid broadcast loops

Quality of Service

- Ingress/egress rate limit per port bandwidth control
- Storm control support
 - Broadcast/unknown unicast/unknown multicast
- Traffic classification
 - IEEE 802.1p CoS
 - ToS/DSCP/IP Precedence of IPv4/IPv6 packets
- Strict priority and Weighted Round Robin (WRR) CoS policies

Multicast

- Supports IGMP snooping v2 and v3
- Supports MLD snooping v1, v2
- IGMP querier mode support
- IGMP snooping port filtering
- MLD snooping port filtering

Security

- Authentication
 - IEEE 802.1X Port-based network access authentication
 - Built-in RADIUS client to co-operate with the RADIUS servers
 - RADIUS/TACACS+ login user access authentication
- Access Control List
 - IPv4/IPv6 IP-based ACL
 - MAC-based ACL
- MAC Security
 - Static MAC
 - MAC filtering
- Port security for source MAC address entries filtering
- DHCP snooping to filter untrusted DHCP messages
- Dynamic ARP inspection discards ARP packets with invalid MAC address to IP address binding
- IP source guard prevents IP spoofing attacks
- DoS attack prevention
- SSH/SSL

Management

- IPv4 and IPv6 dual stack management
- Switch management interface
 - Web switch management
 - Telnet command line interface
 - SNMP v1, v2c and v3
 - SSH/SSL secure access
- User privilege levels control
- Built-in Trivial File Transfer Protocol (TFTP) client
- BOOTP and DHCP for IP address assignment
- System maintenance
 - Firmware upload/download via HTTP/TFTP
 - Configuration upload/download through Web interface
 - Dual images
 - Hardware reset button for system reboot or reset to factory default
- SNTP Network Time Protocol
- Cable diagnostics
- Link Layer Discovery Protocol (LLDP) and LLDP-MED
- SNMP trap for interface linkup and linkdown notifications
- Event message logging to remote Syslog server
- Four RMON groups (history, statistics, alarms and events)
- PLANET Smart Discovery utility

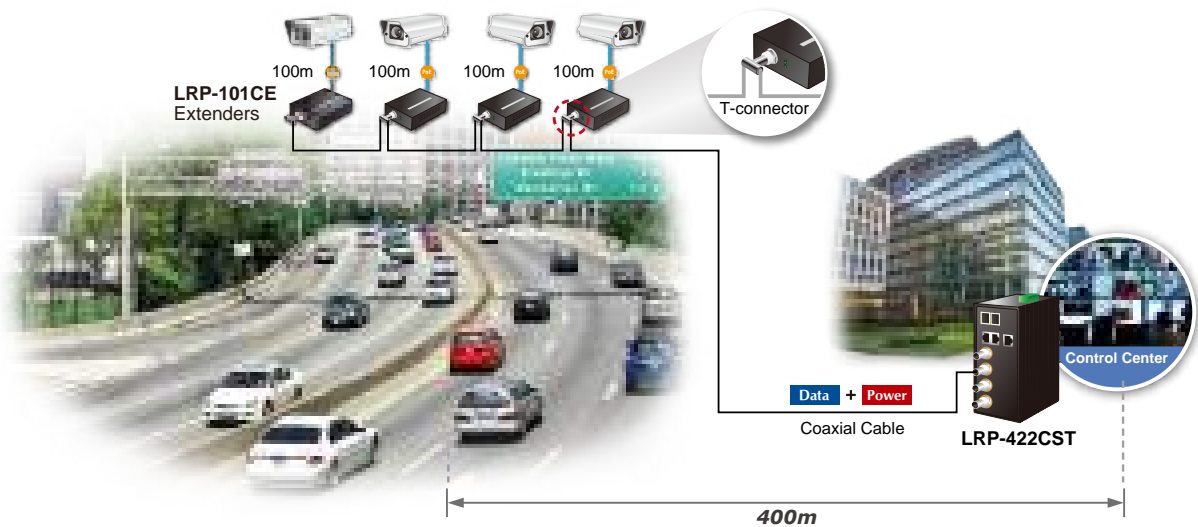

Built-in Unique PoE Functions for Powered Devices Management

As a managed PoE switch for surveillance, wireless and VoIP networks, the LRP-422CST particularly features the following special PoE Management functions to accomplish a highly-efficient Long Reach network:

- PD Alive Check
- Scheduled Power Recycling
- PoE Schedule
- PoE Usage Monitoring

Intelligent Powered Device Alive Check

The LRP-422CST can be configured to monitor connected PD (Powered Device) status in real time via ping action. Once the PD stops working and responding, the LRP-422CST will resume the PoE port power and bring the PD back to work. It will greatly enhance the network reliability through the PoE port resetting the PD's power source and reducing administrator management burden.

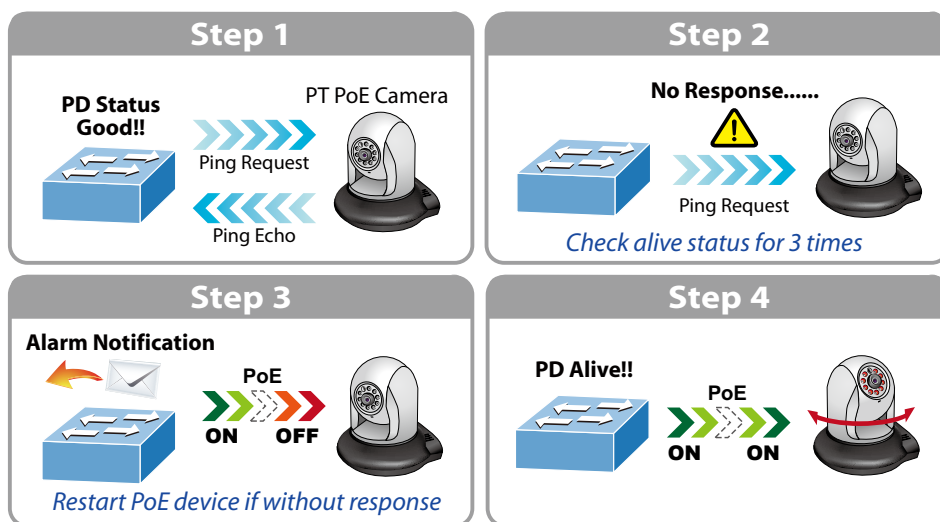

Scheduled Power Recycling

The LRP-422CST allows each of the connected PoE IP cameras or PoE wireless access points via the LRP-101CE Long Reach PoE Extender to reboot at a specific time each week. Therefore, it will reduce the chance of IP camera or wireless AP crash resulting from buffer overflow.

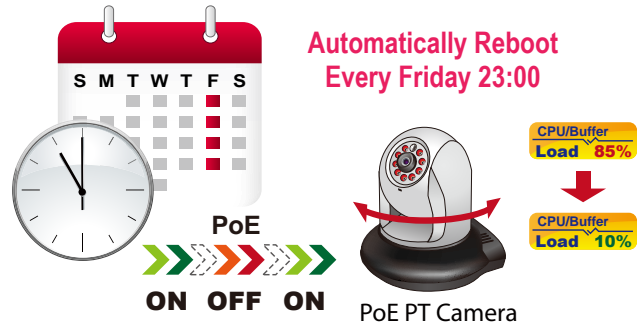

PoE Schedule for Energy Saving

Under the trend of energy saving worldwide and contributing to environmental protection, the LRP-422CST can effectively control the power supply besides its capability of giving high watts power. The “PoE schedule” function helps you to enable or disable PoE power feeding for each PoE port during specified time intervals and it is a powerful function to help SMBs or enterprises save power and budget. It also increases security by powering off PDs that should not be in use during non-business hours.

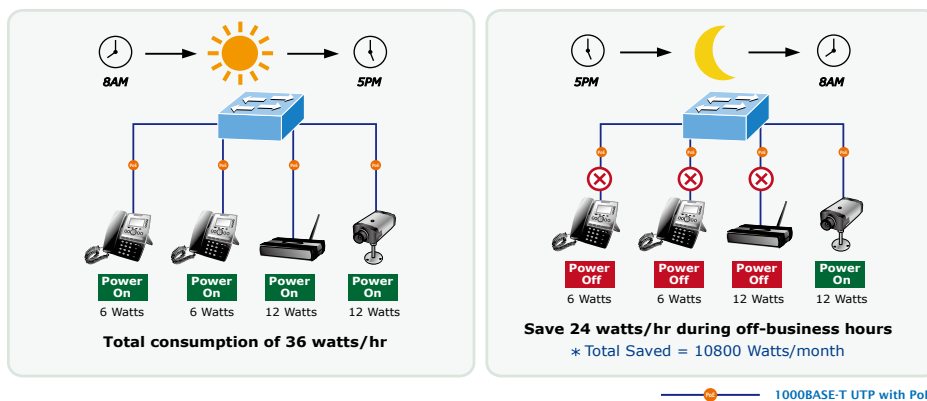

PoE Usage Monitoring

Via the power usage chart in the web management interface, the LRP-422CST enables the administrator to monitor the status of the power usage of the connected PDs in real time. Thus, it greatly enhances the management efficiency of the facilities.

IPv6/IPv4 Dual Stack

Supporting both IPv6 and IPv4 protocols, the LRP-422CST helps the SMBs to step in the IPv6 era with the lowest investment as its network facilities need not be replaced or overhauled if the IPv6 FTTx edge network is set up.

Robust Layer 2 Features

The LRP-422CST can be programmed for advanced switch management functions such as dynamic port link aggregation, 802.1Q VLAN and Q-in-Q VLAN, Multiple Spanning Tree Protocol (MSTP), Loop and BPDU Guard, IGMP Snooping, and MLD Snooping. Via the link aggregation, the LRP-422CST allows the operation of a high-speed trunk to combine with multiple ports such as an 8Gbps fat pipe, and supports fail-over as well. Also, the Link Layer Discovery Protocol (LLDP) is the Layer 2 Protocol included to help discover basic information about neighboring devices on the local broadcast domain.

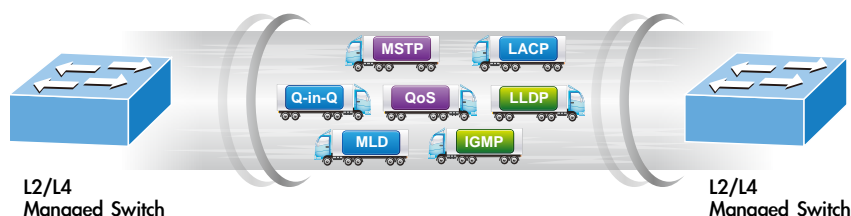

Efficient Traffic Control

The LRP-422CST is loaded with robust QoS features and powerful traffic management to enhance services to business-class data, voice, and video solutions. The functionality includes broadcast/multicast storm control, per port bandwidth control, IP DSCP QoS priority and remarking. It guarantees the best performance for VoIP and video stream transmission, and empowers the enterprises to take full advantage of the limited network resources.

Powerful Security

PLANET LRP-422CST offers comprehensive IPv4/IPv6 Layer 2 to Layer 4 Access Control List (ACL) for enforcing security to the edge. It can be used to restrict network access by denying packets based on source and destination IP address, TCP/UDP ports or defined typical network applications. Its protection mechanism also comprises 802.1X port-based user and device authentication, which can be deployed with RADIUS to ensure the port level security and block illegal users. With the Protected Port function, communication between edge ports can be prevented to guarantee user privacy. Furthermore, Port Security function allows to limit the number of network devices on a given port.

Advanced Network Security

The LRP-422CST also provides DHCP Snooping, IP Source Guard and Dynamic ARP Inspection functions to prevent IP snooping from attack and discard ARP packets with invalid MAC address. The network administrators can now build highly-secure corporate networks with considerably less time and effort than before.

Friendly and Secure Management

For efficient management, the LRP-422CST is equipped with console, Web, Telnet and SNMP management interfaces. With the built-in Web-based management interface, the LRP-422CST offers an easy-to-use, platform-independent management and configuration facility. By supporting the standard Simple Network Management Protocol (SNMP), the switch can be managed via any standard management software. For text-based management, the switch can be accessed via Telnet and the console port. Moreover, the LRP-422CST offers secure remote management by supporting SSH, SSL and SNMP v3 connections which encrypt the packet content at each session.

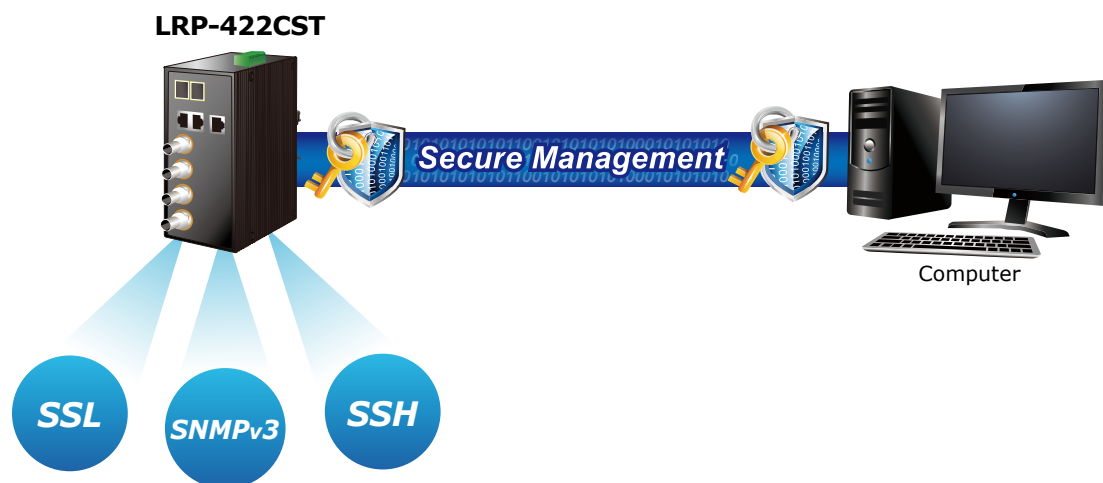

Flexibility and Long-distance Extension Solution

The LRP-422CST provides two Gigabit TP interfaces supporting 10/100/1000BASE-T RJ45 copper to be connected with surveillance network devices such as NVR, Video Streaming Server or NAS to facilitate surveillance management. Or through another two dual-speed fiber SFP slots, it can connect with the 100BASE-FX/1000BASE-SX/LX SFP (Small Form-factor Pluggable) fiber transceiver to uplink to backbone switch and monitoring center in long distance. The distance can be extended from 550 meters to 2 kilometers (multi-mode fiber) and up to 10/20/30/40/50/70/120 kilometers (single-mode fiber or WDM fiber). The LRP-422CST is well suited for applications within the enterprise data centers and distributions.

Intelligent SFP Diagnosis Mechanism

The LRP-422CST also supports SFP-DDM (Digital Diagnostic Monitor) function that can easily monitor real-time parameters of the SFP for network administrator, such as optical output power, optical input power, temperature, laser bias current and transceiver supply voltage, thus increasing the efficiency of network management.

Applications

Directly Upgrade Analog CCTV System to IP-based Security Solution

Under current CCTV system, if you need more channels and higher resolution in longer distance but the CCTV system cannot fulfill your demands, you can use the LRP-422CST via the existing coaxial cable by working with the LRP-101CE Long Reach PoE Extender to instantly establish PoE IP camera infrastructure and to easily upgrade IP camera infrastructure to up to 1024 channels in the future.

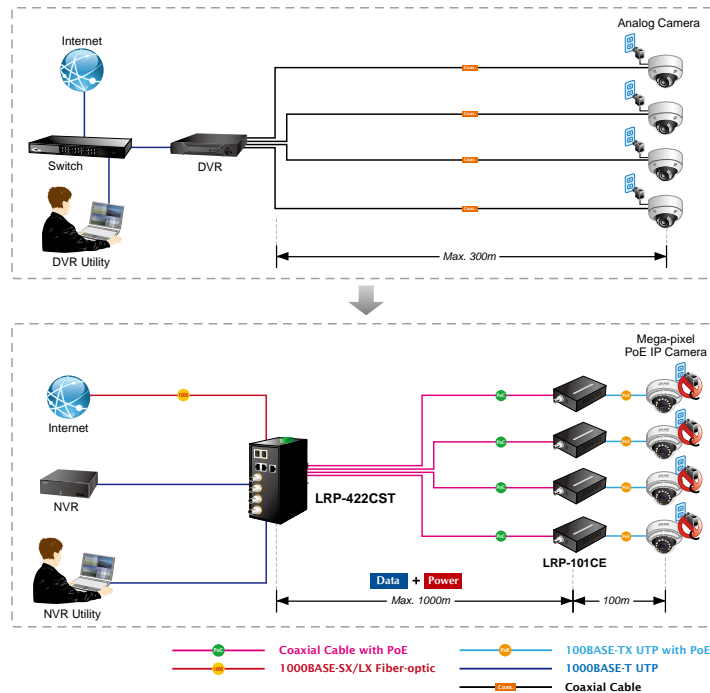

Long Reach PoE IP Surveillance Solution

The LRP-422CST provides robust Long Reach PoE features to prevent network interruptions and extend the transmission of data and power via coaxial cable for up to 1km by working with the LRP-101CE Long Reach PoE Extender. It incorporates PLANET's new Long Reach PoE technology into customer's IP surveillance network to increase the distance of system transmission but to decrease the cost of installation. Applying the Long Reach Power over Ethernet functions in the LRP-422CST, the LRP-101CE can directly connect with any IEEE 802.3at/af end-nodes like IP cameras. Furthermore, the power management of the IP camera system can be centrally controlled by the LRP-422CST.

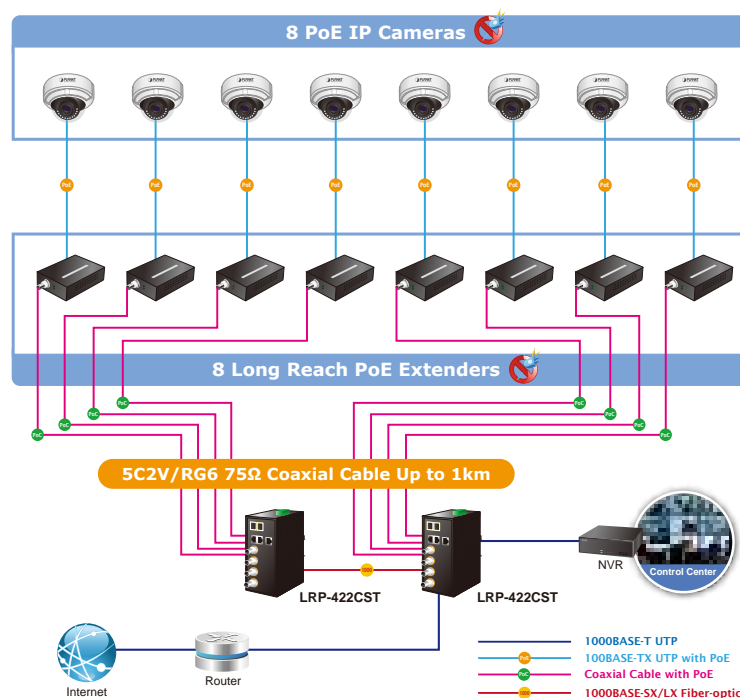

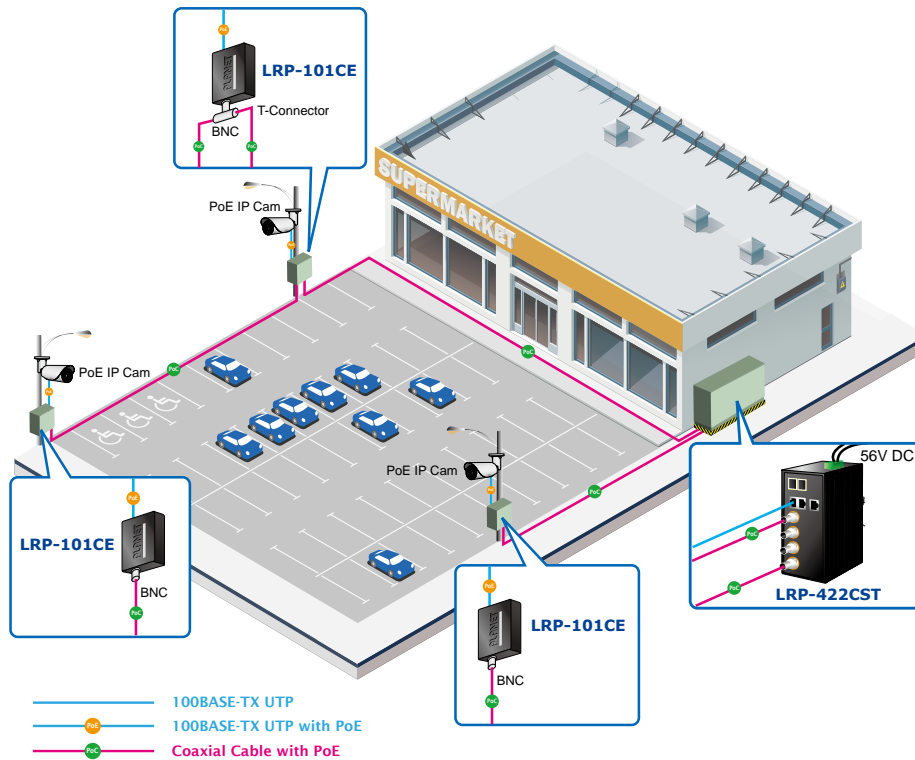

Specifications

Model		LRP-422CST				
Hardware Specifications						
Ethernet Interfaces	Copper	2 x 10/100/1000BASE-T RJ45 Auto-negotiation/Auto-MDI/MDI-X				
	Fiber Optic	2 x 100/1000BASE-X SFP slot Supports 100/1000Mbps dual mode and DDM				
	Jumbo Frame	10Kbytes with GE1 to GE4				
Long Reach PoE Interfaces	Connectivity	4 x BNC female connectors Long Reach PoE over coaxial PSE (Power Source Equipment) – BNC center pole : DC+/Hi – BNC shield : DC -/Lo				
	Power Output	Per port 48~56V DC, 36 watts (max.)				
	Total Power Budget	150 watts (max.)				
	Cabling	Coaxial cable: 75 ohm RG-6/U cable (Recommended)				
	Maximum Distance	Max. 200m with PoE+ output (1,640ft.) Max. 400m with PoE output (2,624ft.) Max. 1200m without PoE output (3,937ft.)				
	Long Reach Ethernet Standard	IEEE 1901				
	Modulation Type	Wavelet-OFDM				
	Security	128-bit AES encryption				
	Frequency Band	2 ~ 28MHz				
	Performance	RG-6/U Distance	Data Rate (Mbps)*		LRP-101CE PoE Output(W)@25 degrees C*	
			TX**	RX**		
200m			93.9	93.5		21.7
400m			90.4	90.3		19.04
600m			82.1	80		13.5
800m			69.6	69.4		10.35
1000m			52.2	50.2		8.01
1200m	31.7	37.8	-			
* The actual data rate and PoE output vary on the quality of the copper wire and environmental factors. The performance result above is based on the testing via the RG-6/U coaxial cable.						
** TX: The LRP-422CST to the LRP-101CE RX: The LRP-101CE to the LRP-422CST						

	Multiple Nodes	Up to 4 LRP extenders within 1km RG-6/U coaxial cable* * The actual extender nodes vary on the quality of the copper wire and environmental factors.	
	LRP Compatibility	LRP-101CE: 1-Port 10/100TX PoE PSE + 1-Port Coax Long Reach PoE Extender	
Console		1 x RS232-to-RJ45 serial port (115200, 8, N, 1)	
Switch Architecture		Store-and-Forward	
Switch Fabric		8.8Gbps/non-blocking	
Address Table		8K entries	
Shared Data Buffer		4.1 megabits	
Flow Control		IEEE 802.3x pause frame for full-duplex Back pressure for half-duplex	
Reset Button		< 5 sec: System reboot > 5 sec: Factory default	
EST Protection		6KV DC	
ESD Protection		6KV DC	
Enclosure		IP30 aluminum case	
Installation		DIN-rail kit and wall-mount kit	
Connector		Removable 6-pin terminal block for power input Pin 1/2 for Power 1; Pin 3/4 for fault alarm; Pin 5/6 for Power 2	
Alarm		One relay output for power failure. Alarm Relay current carry ability: 1A @ 24V AC	
LED		System: Power 1 (Green) Power 2 (Green) Fault Alarm (Red)	Per LRP Port: LNK/ACT (Green) PoE In-use (Orange) Per Gigabit Port: LNK/ACT (Green) 1000(Orange)
Dimensions (W x D x H)		107 x 72 x 152 mm	
Weight		1,150g	
Power Requirements		48 to 56V DC	
Power Consumption		9.5 watts/32.42 BTU (System on) 165 watts/563.0 BTU (Full loading)	
Layer 2 Functions			
Port Mirroring		TX/RX/both Many-to-1 monitor	
VLAN		802.1Q tagged-based VLAN Up to 256 VLAN groups, out of 4094 VLAN IDs 802.1ad Q-in-Q tunneling Voice VLAN Protocol VLAN Private VLAN (Protected port) GVRP	
Link Aggregation		IEEE 802.3ad LACP and static trunk Supports 4 trunk groups with 4 ports for each group	
Spanning Tree Protocol		STP/RSTP/MSTP	
IGMP Snooping		IGMP (v2/v3) Snooping IGMP Querier Up to 256 multicast groups	
MLD Snooping		MLD (v1/v2) Snooping, up to 256 multicast groups	
Access Control List		IPv4/IPv6 IP-based ACL / MAC-based ACL	
QoS		8 mapping IDs to 8 level priority queues - Port number - 802.1p priority - 802.1Q VLAN tag - DSCP field in IP packet Traffic classification based, strict priority and WRR	
Security		IEEE 802.1X port-based authentication Built-in RADIUS client to co-operate with RADIUS server RADIUS/TACACS+ user access authentication IP-MAC port binding MAC filter Static MAC address DHCP Snooping and DHCP Option82 STP BPDU guard, BPDU filtering and BPDU forwarding DoS attack prevention ARP inspection IP source guard	

Management Functions	
Basic Management Interfaces	Web browser/Telnet/SNMP v1, v2c Firmware upgrade by HTTP/TFTP protocol through Ethernet network Remote/Local Syslog System log LLDP protocol SNTP
Secure Management Interfaces	SSH, SSL, SNMP v3
SNMP MIBs	RFC 1213 MIB-II RFC 1215 Generic Traps RFC 1493 Bridge MIB RFC 2674 Bridge MIB Extensions RFC 2737 Entity MIB (Version 2) RFC 2819 RMON (1, 2, 3, 9) RFC 2863 Interface Group MIB RFC 3635 Ethernet-like MIB
Standards Conformance	
Regulation Compliance	FCC Part 15 Class A, CE
Standards Compliance	IEEE 1901 Broadband Power Line IEEE 802.3 10BASE-T IEEE 802.3u 100BASE-TX/100BASE-FX IEEE 802.3z Gigabit SX/LX IEEE 802.3ab Gigabit 1000T IEEE 802.3x flow control and back pressure IEEE 802.3ad port trunk with LACP IEEE 802.1D Spanning Tree Protocol IEEE 802.1w Rapid Spanning Tree Protocol IEEE 802.1s Multiple Spanning Tree Protocol IEEE 802.1p Class of Service IEEE 802.1Q VLAN tagging IEEE 802.1X Port Authentication Network Control IEEE 802.1ab LLDP RFC 768 UDP RFC 793 TFTP RFC 791 IP RFC 792 ICMP RFC 2068 HTTP RFC 1112 IGMP v1 RFC 2236 IGMP v2 RFC 3376 IGMP v3 RFC 2710 MLD v1 RFC 3810 MLD v2
Environment	
Operating	Temperature: -20 ~ 75 degrees C Relative Humidity: 5 ~ 95% (non-condensing)
Storage	Temperature: -40 ~ 85 degrees C Relative Humidity: 5 ~ 95% (non-condensing)

Drawing

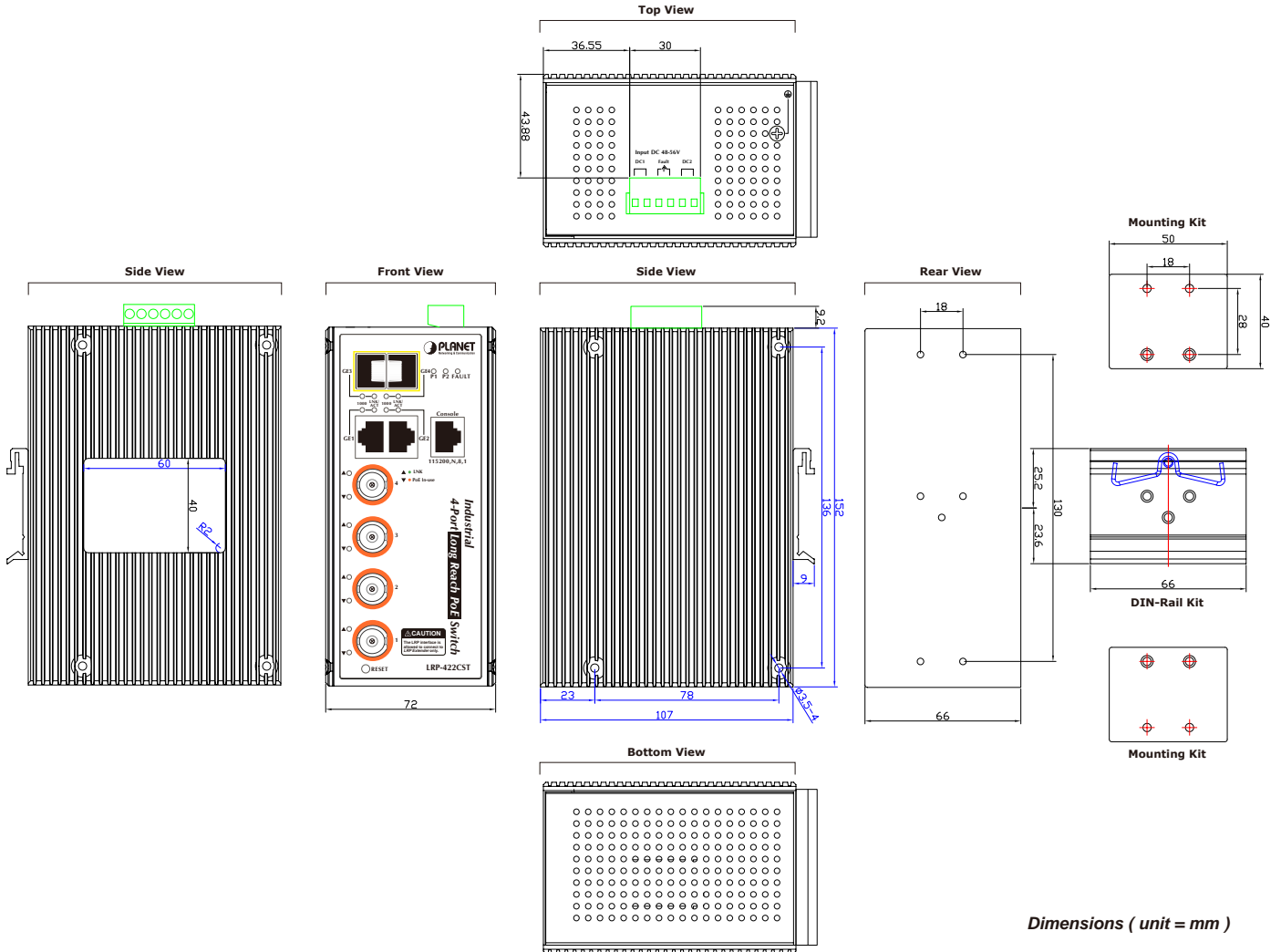

Dimensions (unit = mm)

Ordering Information

LRP-422CST	Industrial 4-port Coax + 2-port 10/100/1000T + 2-port 100/1000X SFP Long Reach PoE over Coaxial Managed Switch
------------	--

Related Products

LRP-1622CS	16-port Coax + 2-port 10/100/1000T + 2-port 100/1000X SFP Long Reach PoE over Coaxial Managed Switch
LRP-822CS	8-port Coax + 2-port 10/100/1000T + 2-port 100/1000X SFP Long Reach PoE over Coaxial Managed Switch
LRP-101CE	1-port 10/100TX PoE PSE + 1-port Coax Long Reach PoE Extender

Available Modules

Fast Ethernet Transceiver (100BASE-X SFP)

Model	Speed (Mbps)	Connector Interface	Fiber Mode	Distance	Wavelength (nm)	Operating Temp.
MFB-FX	100	LC	Multi-Mode	2km	1310nm	0 ~ 60 degrees C
MFB-F20	100	LC	Single Mode	20km	1310nm	0 ~ 60 degrees C
MFB-F40	100	LC	Single Mode	40km	1310nm	0 ~ 60 degrees C
MFB-F60	100	LC	Single Mode	60km	1310nm	0 ~ 60 degrees C
MFB-F120	100	LC	Single Mode	120km	1550nm	0 ~ 60 degrees C
MFB-TFX	100	LC	Multi-Mode	2km	1310nm	-40 ~ 75 degrees C
MFB-TF20	100	LC	Single Mode	20km	1550nm	-40 ~ 75 degrees C

Fast Ethernet Transceiver (100BASE-BX, Single Fiber Bi-directional SFP)

Model	Speed (Mbps)	Connector Interface	Fiber Mode	Distance	Wavelength (TX)	Wavelength (RX)	Operating Temp.
MFB-FA20 MFB-FB20	100	WDM (LC)	Single Mode	20km	1310nm 1550nm	1550nm 1310nm	0 ~ 60 degrees C
MFB-TFA20 MFB-TFB20	100	WDM (LC)	Single Mode	20km	1310nm 1550nm	1310nm 1310nm	-40~75 degrees C
MFB-TFA40 MFB-TFB40	100	WDM (LC)	Single Mode	40km	1310nm 1550nm	1550nm 1310nm	-40~75 degrees C

Gigabit Ethernet Transceiver (1000BASE-X SFP)

Model	Speed (Mbps)	Connector Interface	Fiber Mode	Distance	Wavelength (nm)	Operating Temp.
MGB-GT	1000	Copper	--	100m	--	0 ~ 60 degrees C
MGB-SX	1000	LC	Multi Mode	550m	850nm	0 ~ 60 degrees C
MGB-SX2	1000	LC	Multi Mode	2km	1310nm	0 ~ 60 degrees C
MGB-LX	1000	LC	Single Mode	10km	1310nm	0 ~ 60 degrees C
MGB-L30	1000	LC	Single Mode	30km	1310nm	0 ~ 60 degrees C
MGB-L50	1000	LC	Single Mode	50km	1550nm	0 ~ 60 degrees C
MGB-L70	1000	LC	Single Mode	70km	1550nm	0 ~ 60 degrees C
MGB-L120	1000	LC	Single Mode	120km	1550nm	0 ~ 60 degrees C
MGB-TSX	1000	LC	Multi Mode	550m	850nm	-40 ~ 75 degrees C
MGB-TLX	1000	LC	Single Mode	10km	1310nm	-40 ~ 75 degrees C
MGB-TL30	1000	LC	Single Mode	30km	1310nm	-40 ~ 75 degrees C
MGB-TL70	1000	LC	Single Mode	70km	1550nm	-40 ~ 75 degrees C

Gigabit Ethernet Transceiver (1000BASE-BX, Single Fiber Bi-directional SFP)

Model	Speed (Mbps)	Connector Interface	Fiber Mode	Distance	Wavelength (TX)	Wavelength (RX)	Operating Temp.
MGB-LA10 MGB-LB10	1000	WDM(LC)	Single Mode	10km	1310nm 1550nm	1550nm 1310nm	0 ~ 60 degrees C
MGB-LA20 MGB-LB20	1000	WDM(LC)	Single Mode	20km	1310nm 1550nm	1550nm 1310nm	0 ~ 60 degrees C
MGB-LA40 MGB-LB40	1000	WDM(LC)	Single Mode	40km	1310nm 1550nm	1550nm 1310nm	0 ~ 60 degrees C
MGB-LA60 MGB-LB60	1000	WDM(LC)	Single Mode	60km	1310nm 1550nm	1550nm 1310nm	0 ~ 60 degrees C
MGB-TLA10 MGB-TLB10	1000	WDM(LC)	Single Mode	10km	1310nm 1550nm	1550nm 1310nm	-40 ~ 75 degrees C
MGB-TLA20 MGB-TLB20	1000	WDM(LC)	Single Mode	20km	1310nm 1550nm	1550nm 1310nm	-40 ~ 75 degrees C
MGB-TLA40 MGB-TLB40	1000	WDM(LC)	Single Mode	40km	1310nm 1550nm	1550nm 1310nm	-40 ~ 75 degrees C
MGB-TLA60 MGB-TLB60	1000	WDM(LC)	Single Mode	60km	1310nm 1550nm	1550nm 1310nm	-40 ~ 75 degrees C