

Output Expander, 8 Voltage / 8 Relays

ELK-M1XOVR

APPLICATION:

The ELK-M1XOVR adds 8 Voltage outputs and 8 Relay outputs to the M1 Control. It operates on the 4-wire data bus.

FEATURES:

- 8 Voltage Outputs
- 8 Single-Pole, Double-Pole Relay Outputs
- Operates on the 4-Wire Data Bus
- DIP Switch Address Settings
- One (1) - Twelve (12) Conductor "Flying Lead" Wire Harness
- Voltage Outputs may be converted to Relays using M1RB Relay Boards
- Status LED with Diagnostic Display
- Mounts in Enclosure using ELK-SWG Glides, SWP or SWP3 Structured Wire Plates, or Double Sided Foam Tape

SPECIFICATIONS:

- Voltage Outputs: 12 VDC @ 50 mA each
- Relay Contact Ratings: 7 Amps @ 28 VDC, 10 Amps @ 125 VAC *
- Wire Harness Length: 12"
- Operating Power: 12 VDC
- Current Draw: 65 mA Nom., 330 mA Max.
- Size: 6" x 3.25" x .75" H

* For UL listed installations the maximum contact ratings are 4 Amps @ 12 VDC

Features or Specifications subject to change without notice.

Refer to M1 Installation Manual L520 Rev. J for additional information

Installation

1. A single M1XOVR Expander can be mounted inside the M1 enclosure on the left hand side of the M1 board using the supplied ELK-SWG Circuit Board Glides. If any additional expanders are required, they can be mounted in either an ELK-SWB14 or ELK-SWB28 enclosure. Up to 8 expanders can be mounted in an SWB14 while up to 16 expanders can be mounted in an SWB28.

The ELK-SWG Circuit Board Glides attach to the enclosure at strategically placed 2-hole punch patterns. Note that one hole in each pattern is slightly larger than the other. The small hole is for a 6/32 type "F" mounting screw and the large hole is for a half-moon shape locator tab on the bottom of each glide.

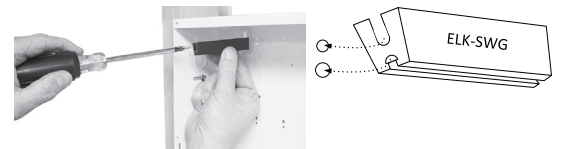

2. Starting at the top left corner, loosely start a 6/32" mounting screw in the small hole of the first 2-hole pattern. Place the slotted edge of a board glide under this screw, making sure that the half-moon tab fits into the larger hole and the grooved edge is facing down. Tighten the screw using a long shafted screwdriver. Install a second board glide in the 2-hole pattern located 6" below. Attach the second board glide using the same procedures. The grooved edge of this glide should face up.
3. Slide the expander board into the grooves provided by the glides. The circuit board should slide freely. If the board is loose or too tight, simply loosen one of the mounting screws and adjust the glide to assure a good fit.

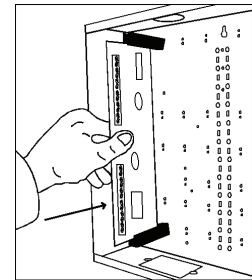

Wiring Connections

1. Turn Control Panel Master Power Switch Off.
2. Use a 4 wire cable to connect terminals +VKP, Data A, Data B, and Neg from Control to terminals 12V, A, B, and Neg on the M1XOVR. **IMPORTANT NOTE:** If the expander is remotely mounted, refer to information in the M1 Installation Manual for important information about data bus devices connected to multiple homerun cables.
3. Set Address Switches according to Table 1.
4. Turn the M1 Master Power Switch On.
5. Enroll the M1XOVR to the M1 Control using the following procedure: Enter Installer level programming and select Menu 01-Bus Module Enrollment. Press the right arrow key to start enrollment. To view the results, press the right arrow "edit" key.
6. After enrollment, use the ELK RP Rules programming to assign the new outputs.

NOTE: If it becomes necessary to replace an enrolled device, set the new unit to the same address and repeat the enrollment. If permanently removing a device, un-enroll it to prevent a trouble condition.

PO Box 100 • Hildebran, NC 28637 USA • 828-397-4200 Voice • 828-397-4415 Fax
<http://www.elkproducts.com> • email: info@elkproducts.com

L529 02/19/2024

ELK
PRODUCTS

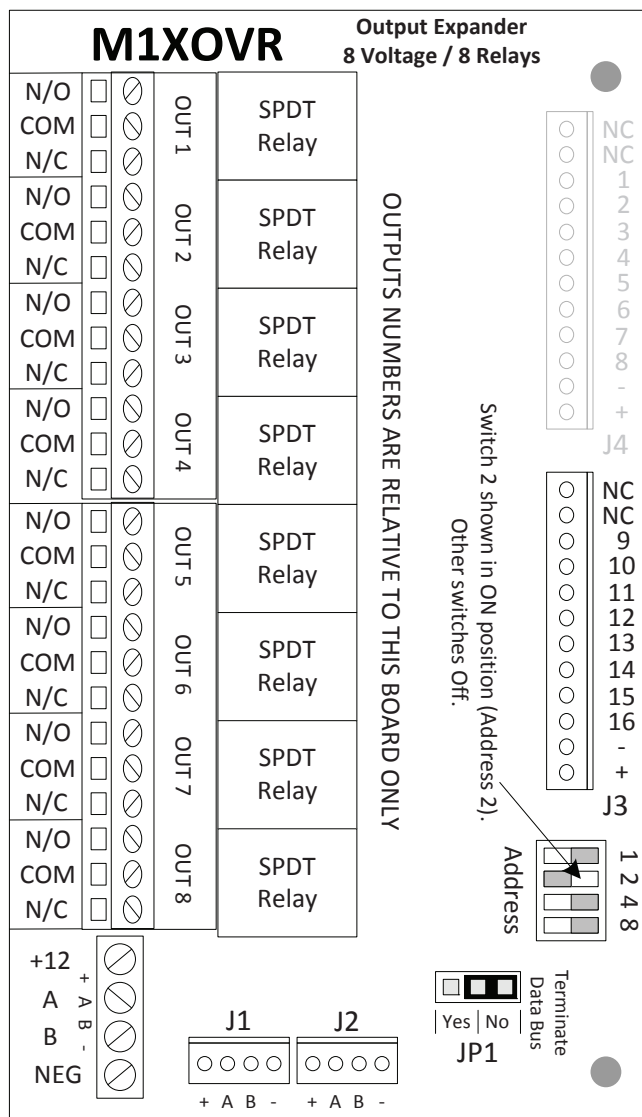

ADDRESS SETTING: Locate the four "Address" switches. Each has a position of OFF or ON (binary 0 or 1) with a decimal equivalent of (1, 2, 4, or 8). The total decimal value for the "ON" switches sets the bus address. This determines which outputs (banks of 16) are assigned to the expander. E.G. Address 5 would be set with switches 1 and 3 ON (1+4=5) and switches 2 and 4 OFF. Outputs Expanders are factory pre-set to address 2 (Outputs 17 to 32).

NOTE: Jumper JP1 is used to engage an on-board 120 Ohm resistor for terminating the RS-485 Data Bus. See Data bus wiring instructions before use.

Data Bus Address	Outputs assigned to this expander	Dip Switches			
		1	2	3	4
1	Outputs 1-16	ON	OFF	OFF	OFF
2	Outputs 17 - 32	OFF	ON	OFF	OFF
3	Outputs 33 - 48	ON	ON	OFF	OFF
4	Outputs 49 - 64	OFF	OFF	ON	OFF
5	Outputs 65 - 80	ON	OFF	ON	OFF
6	Outputs 81 - 96	OFF	ON	ON	OFF
7	Outputs 97 - 112	ON	ON	ON	OFF
8	Outputs 113 - 128	OFF	OFF	OFF	ON
9	Outputs 129 - 144	ON	OFF	OFF	ON
10	Outputs 145 - 160	OFF	ON	OFF	ON
11	Outputs 161 - 176	ON	ON	OFF	ON
12	Outputs 177 - 192	OFF	OFF	ON	ON
13	Outputs 193 - 208	ON	OFF	ON	ON

Table 1: Output "Bank" Assignments

Utilizing an M1DBH Data Bus Hub

Since the M1XOVR connects to the M1's RS-485 Data Bus, it can be installed inside the Control or virtually anywhere along the data bus. The Data Bus requires only 4 wires, 2 for power + 2 for data. However, due to the relatively high speed of the data bus, special wiring connections are necessary to avoid data reflection errors on long cables OR multiple cable "homeruns". **See the M1 Installation Manual for important information about Data Bus termination, including methods and recommendations for avoiding data bus problems.** The primary goal is to have no more than 2 data bus branches (cables) running from the control, with each being terminated at its end using a 120 Ohm end of line resistor. There are two ways to accomplish this goal. 1) Using 4-wire cable, run no more than 2 cables and connect all devices paralleled (daisy chained) along this cable path. OR 2) Using 6 or 8 wire cables (CAT5 or CAT6 is ideal), run as many cables as you want so long as the data A & B wires are connected to a spare pair of wires so that they double back (return) to the control and are connected in series to the outgoing data A & B lines of the next cable. By keeping the data lines in a series circuit it will appear to be one long cable. This virtually eliminates data reflection errors. This is easily done using an ELK-M1DBH Data Bus Hub.

IMPORTANT INFORMATION

Do Not Use the 8 M1XOVR Voltage outputs to directly drive high (large) current loads. Each output is limited to 50 mA.

Also, when calculating the M1 total current load, keep in mind that if all 8 outputs from an M1XOVR were turned on and were drawing the maximum of 50 ma each, the resulting total load would be 400 mA from the M1. An auxiliary power supply may be required and is strongly recommended if the M1XOVR is remotely mounted from the M1 Control.

Door Strike

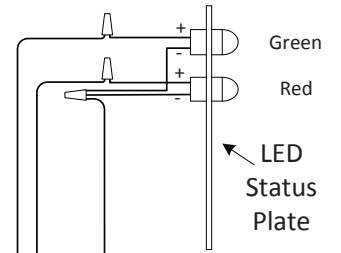
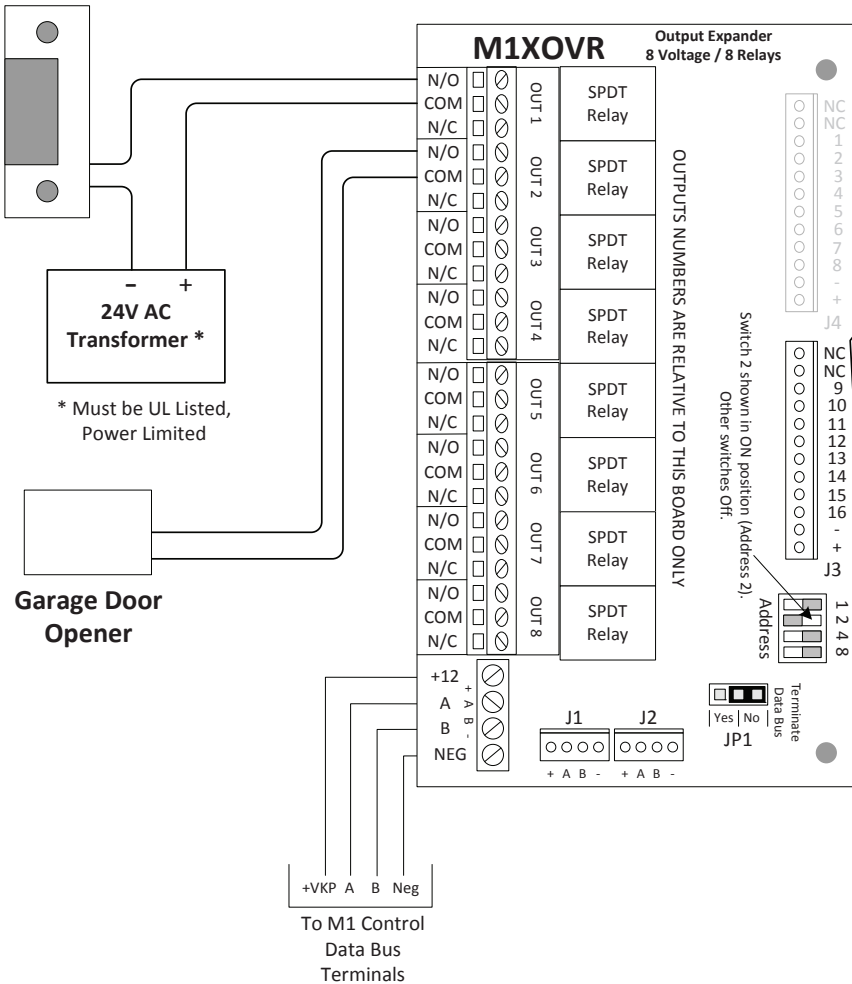

Using the M1XOVR to drive two (2) indicator LEDs on an LED Status Plate

- Tan - Not Used
- Pink - Not Used
- Gray - Output 09
- Purple - Output 10
- Yellow - Output 11
- Orange - Output 12
- Blue - Output 13
- Brown - Output 14
- Green - Output 15
- White - Output 16
- Black - Negative
- Red - +12 VDC

Examples of Hookups using ELK-M1OVR Output Board