



NOP-RI12MS

Hardware Manual

Revision A7
August *, 2025**

© 2025 Azure Access Technology, Inc.

All rights reserved. No parts of this work may be reproduced in any form or by any means - graphic, electronic, or mechanical, including photocopying, recording, taping, or information storage and retrieval systems - without written permission.

While every precaution has been taken in the preparation of this document, Author assumes no responsibility for errors or omissions, or for damages resulting from the use of information contained in this document or from the use of programs and source code that may accompany it. In no event shall the publisher and the author be liable for any loss of profit or any other commercial damage caused or alleged to have been caused directly or indirectly by this document.

NOP-RI2MS Hardware Manual

Downstream 2-Door Reader Interface

by Azure Access Technology

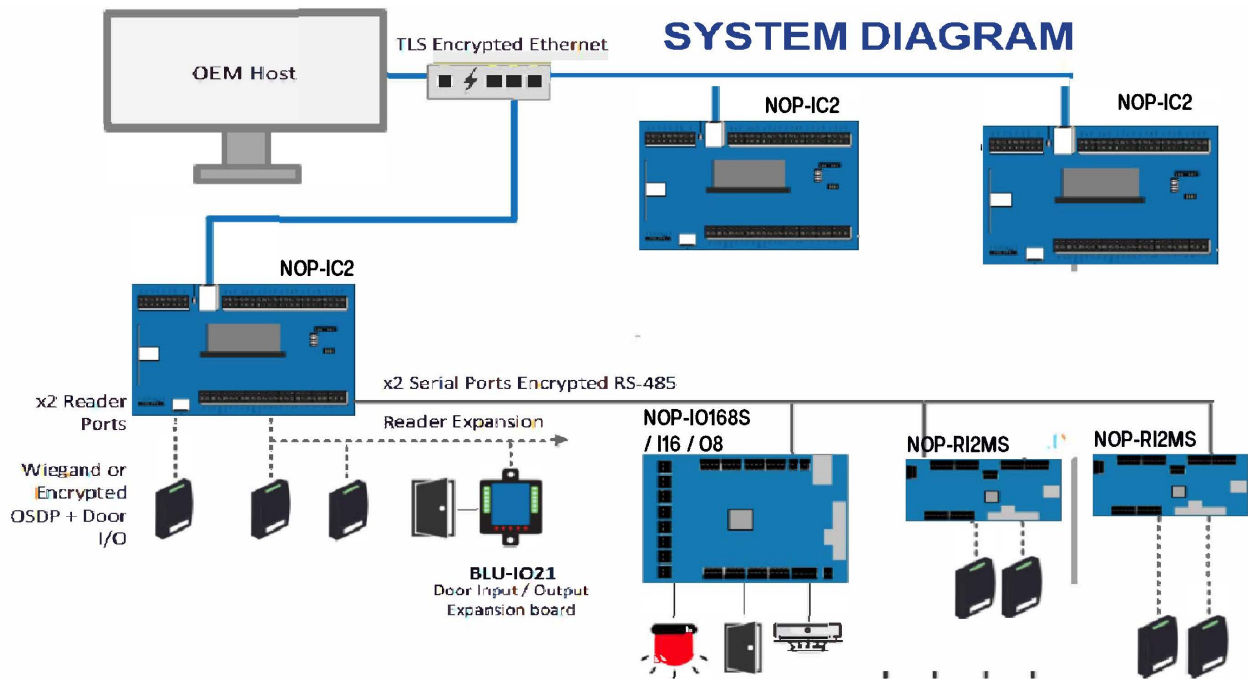
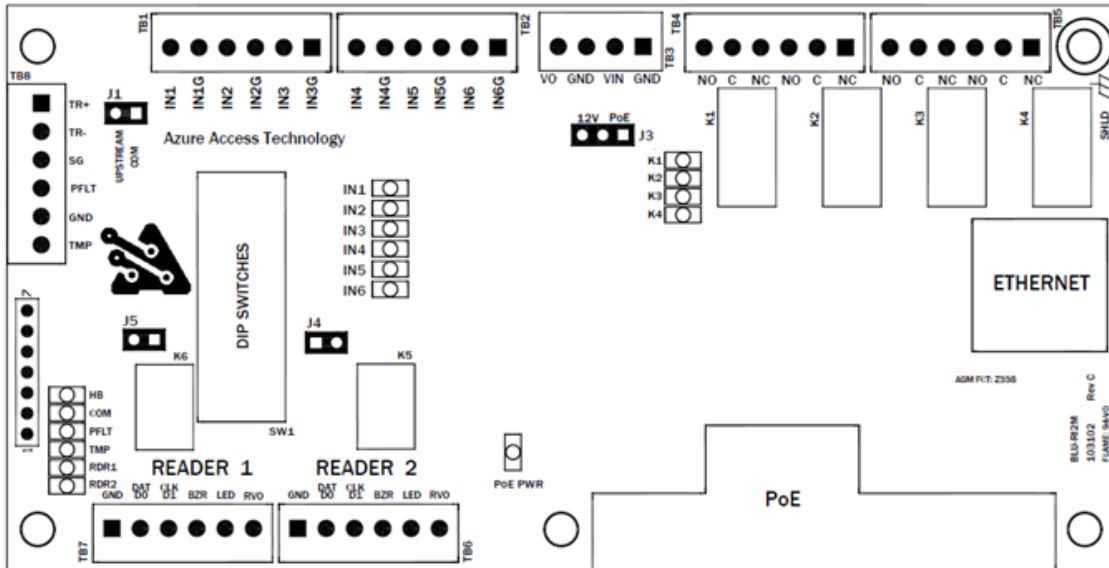

IMPORTANT INFORMATION



WARNING

HIGH VOLTAGE, AC MAIN POWER SHOULD ONLY BE CONNECTED BY QUALIFIED, LICENSED ELECTRICIANS. ALL APPLICABLE LAWS AND CODES MUST BE FOLLOWED. IF THIS PRECAUTION IS NOT OBSERVED, PERSONAL INJURY OR DEATH COULD OCCUR

Power should not be applied to the system until after the installation has been completed. If this precaution is not observed, personal injury or death could occur, and the equipment could be damaged beyond repair.

-Verify that the external circuit breaker which supplies power to the device power supply is turned off prior to installation.

-Verify that the output voltage of the power supply is within specifications prior to connection to the device.



CAUTION

Several important procedures should be followed to prevent electro-static discharge (ESD) damage to sensitive CMOS integrated circuits and modules.

-All transport of electronic components, including completed reader assemblies, should be in static shield packaging and containers.

-Handle all ESD sensitive components at an approved static controlled work station. These work stations consist of a desk mat, floor mat and an ESD wrist strap. Work stations are available from various vendors including the 3M company.

FCC Compliant

This device complies with Part 15 of FCC Rules. Operation is subject to the following two conditions:

1. This device may not cause harmful interference, and
2. This device must accept any interference received, including interference that may cause undesired operation.

This equipment has been tested and found to comply with the limits for a Class A digital device, pursuant to Part 15 of the FCC Rules. These limits are designed to provide reasonable protection against harmful interference when the equipment is operated in a commercial environment. This equipment generates, uses, and can radiate radio frequency energy and, if not installed and used in accordance with the instruction manual, may cause harmful interference to radio communications. Operation of this device in a residential area is likely to cause harmful interference in which case the user will be required to correct the interference at his/her own expense. The user is advised that any equipment changes or modifications not expressly approved by the party responsible for compliance would void the compliance to FCC regulations and therefore, the user's authority to operate the equipment.

CE Compliant

UL & ULC Recognized

- UL294
- UL294B
- UL2610
 - UL1076 & ULC/ORD 1076 – Depreciated
- UL2043 Plenum Enclosure

OSDP Verified – Secure Profile (as of firmware ver 1.26.0)



Table of Contents

1	INTRODUCTION	1
1.1	General Features	12
	Hardware Layout.....	2
2.1	Terminal Connectors.....	2
2.2	Jumpers.....	5
2.3	LEDs	6
2.4	Dip Switches	7
2.5	Mounting	8
3	SYSTEM WIRING & SETUP	9
3.1	Power (TB3).....	9
3.1.1	Powering Peripherals	9
3.2	Upstream RS-485 Serial Port (TB8).....	10
3.2.1	Device Wiring	10
3.2.2	Bus Configuration	10
3.2.3	Termination.....	11
3.2.4	Signal Ground (SG).....	11
3.3	Unsupervised Cabinet Tamper & Power Fault (TB8)	11
3.4	Reader Ports (TB6 & TB7).....	12
3.4.1	TTL Readers.....	12
3.4.2	RS-485 (OSDP) Readers	13
3.5	Supervised Alarm Inputs (TB1 & TB2).....	13
3.5.1	End of Line (EOL) Termination Resistors	14
3.6	Output Relays (TB4 & TB5).....	15
3.6.1	Door Strike Wiring	15
3.6.2	Auxiliary Output Relay	16
3.6.3	Voltage Spike Suppression	16
3.7	Door / Access Point Setup.....	16
3.7.1	Reader.....	17
3.7.2	Door Contact & Exit Pushbutton/REX Inputs.....	17
3.7.3	Door Strike.....	17
4	OPERATION	18
4.1	Firmware.....	18
4.1.1	Gen2 vs Gen3	18
4.1.2	Bootloader	18
4.2	Serial COM Configuration.....	18
4.2.1	Serial COM Encryption	18
4.3	Offline Mode (Firmware 1.23)	18
4.4.1	Offline Events	18
4.4.2	Configurable Offline Modes	19
5	TROUBLESHOOTING	19
5.1	Serial RS-485.....	19
5.3	Alarm Device Input	19
5.4	Output Relays	19
6	SPECIFICATIONS.....	20
7	REVISION HISTORY.....	22

Part I

Introduction

1 Introduction

The NOP-RI2MS is a downstream, reader interface board. It communicates with a NOP-IC series controller over a serial or network connection. This is a low-profile device that can be installed near or at the door. It features 2-door control with two independent TTL or OSDP reader ports, supporting 6 supervised inputs, and 4 relay outputs. The board runs an enhanced version of OSDP protocol to communicate with the controller.

The RI2MS provides interface connections for a variety of card reader technologies, including proximity, smart card, biometric, bar code, and infrared readers. Card readers with standard Wiegand or Clock/Data output can be connected to the RI2MS as well as card readers that use OSDP protocol.

1.1 General Features

- Two onboard reader ports for TTL or OSDP readers with paired reader support
- Communication: One 2-wire RS-485 & one 10/100 Ethernet port
 - Serial and network communications are encrypted
- 6 Supervised or Unsupervised Inputs
 - Configurable termination-resistor values
- 4 Relay Outputs
- Inputs & Outputs fully re-assignable
- One 2-wire RS-485 port for upstream communication
 - Supports proprietary or OSDP protocol
- Cabinet Tamper Input
- Power Fault Input
- Configuration DIP switches
- 1 LED Output per reader port (tri-state control)
- 1 Buzzer Output (open collector) per reader port
 - Buzzer output can be repurposed for 2-wire LED control
- 12 VDC only

Part II

Hardware Layout

2 Hardware Layout

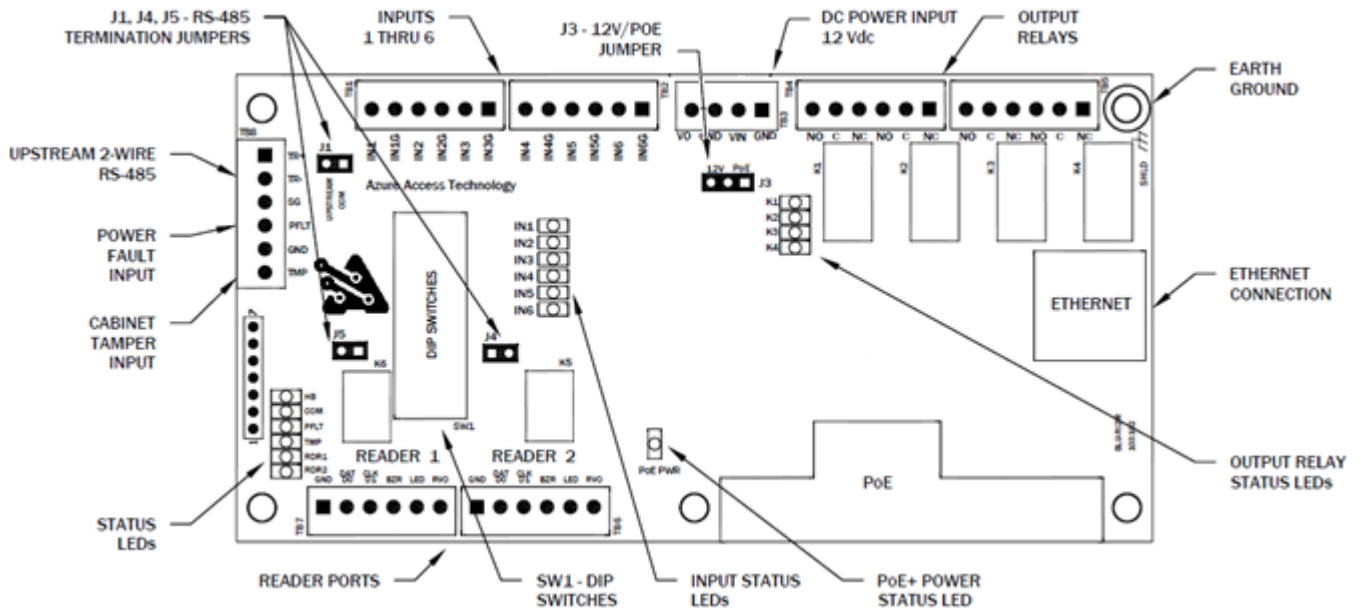

Figure 2.1: Board Diagram

2.1 Terminal Connectors

The RI2MS uses terminal blocks for connecting power, readers & door control signals, communications, supervised alarm inputs, and relay output connections. The connection terminals are factory equipped with removable screw-down quick connectors which are easily removed from the board by firmly grasping the connector and pulling away from the board. If pliers are used to remove the connectors, they should be of the rubber-tipped type. Take care to not damage onboard components when using any tools near the board. The proper location of the quick connectors is outlined in white on the board.

The SDK allows for any readers, inputs, and outputs to be assigned to any door, but a recommended connection is listed in parenthesis in the function column.

Terminal Block Wiring Connections			
Location	Type	Label	Function (Recommended Connection)
Power			
TB3-1	Ground	GND	12VDC VIN input power connection
TB3-2	Input Power	VIN	
TB3-3	Ground	GND	Fuse-protected, 12VDC power distribution
TB3-4	AUX Power Output	VOUT	
Serial Port			
TB8-3	Signal Ground	SG	Serial 2-wire RS-485
TB8-2	Transmit/Receive Data (-)	TR-	
TB8-1	Transmit/Receive Data (+)	TR+	
Reader Ports			
TB7-1	Reader Power Ground	GND	Reader 1 (Door 1 Reader) Host can configure to connect to Wiegand / Clock & Data or OSDP Readers
TB7-2	TTL: Data/Data 0 RS485: TR-/B	DAT/D0	
TB7-3	TTL: Clock/Data 1 RS485: TR+/A	CLK/D1	
TB7-4	Beeper (Buzzer) Control	BZR	
TB7-5	LED Control	LED	
TB7-6	Reader Power	RVO	
TB6-1	Reader Power Ground	GND	Reader 2 (Door 2 Reader) Host can configure to connect to Wiegand / Clock & Data or OSDP Readers
TB6-2	TTL: Data/Data 0 RS485: TR-/B	DAT/D0	
TB6-3	TTL: Clock/Data 1 RS485: TR+/A	CLK/D1	
TB6-4	Beeper (Buzzer) Control	BZR	
TB6-5	LED Control	LED	
TB6-6	Reader Power	RVO	
Supervised Inputs			
TB1-6	Input 1	IN1	Input 1 (Door 1 Door Contact)
TB1-5	Input 1 Return	IN1G	
TB1-4	Input 2	IN2	Input 2 (Door 1 REX/EPB)
TB1-3	Input 2 Return	IN2G	
TB1-2	Input 3	IN3	Input 3 (Door 1 AUX Input)
TB1-1	Input 3 Return	IN3G	
TB2-6	Input 4	IN4	Input 4 (Door 2 Door Contact)
TB2-5	Input 4 Return	IN4G	

TB2-4	Input 5	IN5	Input 5 (Door 2 REX/EPB)
TB2-3	Input 5 Return	IN5G	
TB2-2	Input 6	IN6	Input 6 (Door 2 AUX Input)
TB2-1	Input 6 Return	IN6G	
Tamper & Power Fault Inputs			
TB8-6	Cabinet Tamper	TMP	Cabinet Tamper & Power Fault with shared GND connection point
TB8-5	Ground	GND	
TB8-4	Power Fault	PFLT	
Relay Outputs			
TB4-6	Normally Open	NO	Relay OUT 1 (Door 1 Strike)
TB4-5	Common	C	
TB4-4	Normally Closed	NC	
TB4-3	Normally Open	NO	Relay OUT 2 (Door 2 Strike)
TB4-2	Common	C	
TB4-1	Normally Closed	NC	
TB5-6	Normally Open	NO	Relay OUT 3 (Door 1 AUX Output)
TB5-5	Common	C	
TB5-4	Normally Closed	NC	
TB5-3	Normally Open	NO	Relay OUT 4 (Door 2 AUX Output)
TB5-2	Common	C	
TB5-1	Normally Closed	NC	

Figure 2.2: Terminal Connections

2.2 Jumpers

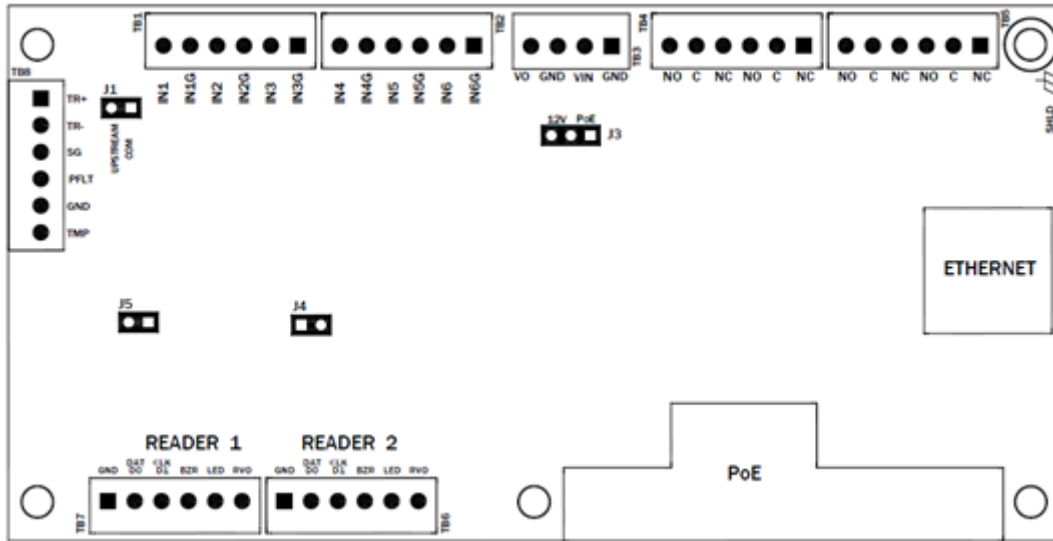



JUMPER	SETTING	DESCRIPTION
J1	ON/OFF	RS485 termination - Serial Port (UPSTREAM COM)
J3 Labeled "12V PoE"	12V PoE 	Select PoE+ power source *Not Applicable with the NOP-RI2MS
	12V PoE 	Select 12 DC/DC Power supply source (DEFAULT)
J4	ON/OFF	RS485 termination - Reader Port 2 (RDR2)
J5	ON/OFF	RS485 termination - Reader Port 1 (RDR1)

Figure 2.3: User-installed jumper settings

Note: RS485 termination jumpers (J1, J4, & J5) are shipped from the factory in the OFF (termination disengaged) position. Only turn ON termination if the RI2MS is at the end of the serial bus.

2.3 LEDs

The RI2MS has 19 LEDs for monitoring panel function.

Status LEDs	
HB	Heartbeat Offline – 200ms ON, 800ms OFF Online – 800ms ON, 200ms OFF
COM	RS-485 Serial Port – Flashes when data is received
TMP	Cabinet Tamper & Power Supply Fault – See Note 1 ON = Alarm
PFLT	OFF = Secure • When running in the bootloader, TMP & PFLT will alternate flashing on/off
RDR1	Reader Port 1 & 2 OSDP Reader – Flashes when communicating with reader
RDR2	Wiegand Reader – Flashes when receiving card data
Alarm Zone Inputs LEDs	
IN1 – IN6	Supervised Input 1-6 Statuses – See Note 1 ON = Alarm OFF = Secure Flash = Fault
Output Relays	
K1 – K4	Relay OUT 1-4 (K1 through K4) ON = Energized OFF = De-Energized
Ethernet (P1)	
Speed (left side)	ON = 100Mbps network connection
Link (right side)	Flashing = Network activity present

Figure 2.4: LED status definitions

Note 1: Every 4 seconds the LED is pulsed to its opposite state for 0.1 seconds

2.4 Dip Switches

DIP Switch Functions

The RI2MS has 12 DIP switches. These switches are used to set various configuration options. All DIP switch settings, except Factory Reset, do not require a power cycle to take effect.

Communications Address					
Sets this device's physical address on the RS-485 bus or network port. This number must be unique for each device on a single bus or port.					
1	2	3	4	5	Address
OFF	OFF	OFF	OFF	OFF	0
ON	OFF	OFF	OFF	OFF	1
OFF	ON	OFF	OFF	OFF	2
ON	ON	OFF	OFF	OFF	3
OFF	OFF	ON	OFF	OFF	4
ON	OFF	ON	OFF	OFF	5
OFF	ON	ON	OFF	OFF	6
ON	ON	ON	OFF	OFF	7
OFF	OFF	OFF	ON	OFF	8
ON	OFF	OFF	ON	OFF	9
OFF	ON	OFF	ON	OFF	10
ON	ON	OFF	ON	OFF	11
OFF	OFF	ON	ON	OFF	12
ON	OFF	ON	ON	OFF	13
OFF	ON	ON	ON	OFF	14
ON	ON	ON	ON	OFF	15
OFF	OFF	OFF	OFF	ON	16
ON	OFF	OFF	OFF	ON	17
OFF	ON	OFF	OFF	ON	18
ON	ON	OFF	OFF	ON	19
OFF	OFF	ON	OFF	ON	20
ON	OFF	ON	OFF	ON	21
OFF	ON	ON	OFF	ON	22
ON	ON	ON	OFF	ON	23
OFF	OFF	OFF	ON	ON	24
ON	OFF	OFF	ON	ON	25
OFF	ON	OFF	ON	ON	26
ON	ON	OFF	ON	ON	27
OFF	OFF	ON	ON	ON	28
ON	OFF	ON	ON	ON	29
OFF	ON	ON	ON	ON	30
ON	ON	ON	ON	ON	31

Baud Rate (Upstream RS-485 Port)	6	7
Note: The baud rate must be the same for every device on this port.		
9600 Baud	OFF	OFF
38400 Baud	ON	OFF
57600 Baud	OFF	ON
115200 Baud	ON	ON
230400 Baud (Software-set ONLY)	-	-

DIP RS485 Config Override	8
Select if OSDP cmds are accepted to set baud and address	
Accept OSDP cmds to set baud/address. DIP switch settings for address and baud rate are ignored. Note: After a Factory Reset, DIP switch address and baud settings are used until new config is sent.	OFF
Address and baud rate are set with DIP switches. OSDP commands to set address or baud rate will be ignored and the reply to the command, which lists the address in baud in use, will reflect the DIP switch set values. Note: An address and/or baud rate previously set by software is still retained.	ON

Network Configuration	9
Use user config	OFF
Use default config	ON

Default Network Login	10
Disable default login	OFF
Enable default login	ON

FACT/OSDP Key Reset	11
Power up board with switch ON and all LEDs blink rapidly for 3 seconds. If the switch is turned OFF within the 3 seconds, the board performs factory reset including wiping out custom OSDP keys. After the 3 seconds, if the switch has not been turned OFF, the board will run normally.	Toggle
Toggle this DIP switch during normal operation or after the 3 seconds does nothing.	

Reserved	12
X	OFF

Figure 2.5: DIP Switch Settings

Part III

System Wiring & Setup

3 System Wiring & Setup

This section will provide installation and wiring instructions as well as hardware interface information as it applies to the access control system. To guard personal safety and avoid damaging equipment it is important to have a full understanding of electrical wiring best-practices and safety. The following sections provide general guidelines relating to the RI2MS, but are not a substitute for formal training in safely handling electrical systems!

3.1 Power (TB3)

DC/DC

The NOP-RI2MS is powered with a 12VDC power supply. In the case of over-current, solid-state fuses integrated on the RI2MS will 'trip' to protect the components of the panel. In many cases, the solid-state fuses will reset automatically when normal current resumes, however it may be necessary to interrupt the supply of power to allow the fuses to reset.

Take care when selecting a power supply for use with the RI2MS. Most power supplies on the market today provide good input/output isolation, however those which do not provide isolation (or have high leakage capacitance), coupled with accidental AC power line interchange, presents serious ground fault problems for installers. With ground fault, the signal reference between subsystems may be 115 Vac (230 Vac) apart. If these subsystems are interconnected, the large potential difference will cause equipment damage or personal injury. Azure Access recommends the use of isolated continuous power from supplies only.

DC Ground

This is typically the minus (-) side of the DC output of the power supply. All devices powered by the supply must connect to the same supply's DC Ground (-). Never connect to Safety (Earth) Ground on the AC side.

AC Ground ("Safety" / "Earth" / "Chassis" Ground)

To avoid ground loop current, there must be only ONE point at which the AC ground connects to the DC ground (usually through the DC/DC power supply). The plated, "chassis" mounting hole should be electrically connected the conductive surface of the mounting plate or enclosure.

3.1.1 Powering Peripherals

The RI2MS has multiple output ports for distributing power to peripheral devices. Each port has its own voltage and current specs and have overcurrent protection in the form of auto-resetting fuses.

The installer must adhere to overall current maximums of the power supply. Detailed electrical specs are in the "Specifications" section of this document (section 6).

To maximize longevity, it is not recommended to fully load all peripheral power ports when operating at the top of the operating temperature range.

Auxiliary Output Power "VO" (TB3 – pin 4)

The VO port can be used to power peripheral devices such as strikes, IO modules, readers, etc. This port is a direct passthrough from the primary power VIN (same voltage as VIN. This port has a 1 Amp current maximum.

Reader Port Power "RVO" (TB6 – pin 6) & (TB7 – pin 6)

Readers can be powered directly from the two reader ports. Each port has a maximum current rating of 500mA.

3.2 Upstream RS-485 Serial Port (TB8)

RS-485 is an electrical interface standard for multi-point communication on bus transmission lines. It allows high speed data transfer over extended distance (4000ft, 1219m). An RS-485 Serial Bus is a typical connection for downstream devices to a controller. The RI2MS is a slave device on the bus that responds to communications from the controller (master).

3.2.1 Device Wiring

The RI2MS uses a 2-wire RS485 bus topology. Make sure to match polarities of your wiring connection; positive (+) to positive and negative (-) to negative. Wiring recommendation of 24 AWG, shielded twisted-pair. Wiring requirements satisfied by Belden 9841/9842 or equivalent.

2-wire RS-485 consists of three wires; TR+, TR-, & SG (signal ground). Both TX and RX are done on the same pair of wires. The BLU-IC2 serial port interface is 2-wire and is wired as "Standard 2-Wire Bus" shown in the Figure below.

The BLU-IC4 has a 4-wire interface that can be converted to 2-wire but shorting both TX+ & RX+ together and TX- & RX- together. See "Mixed 2-Wire Bus" in Figure below...

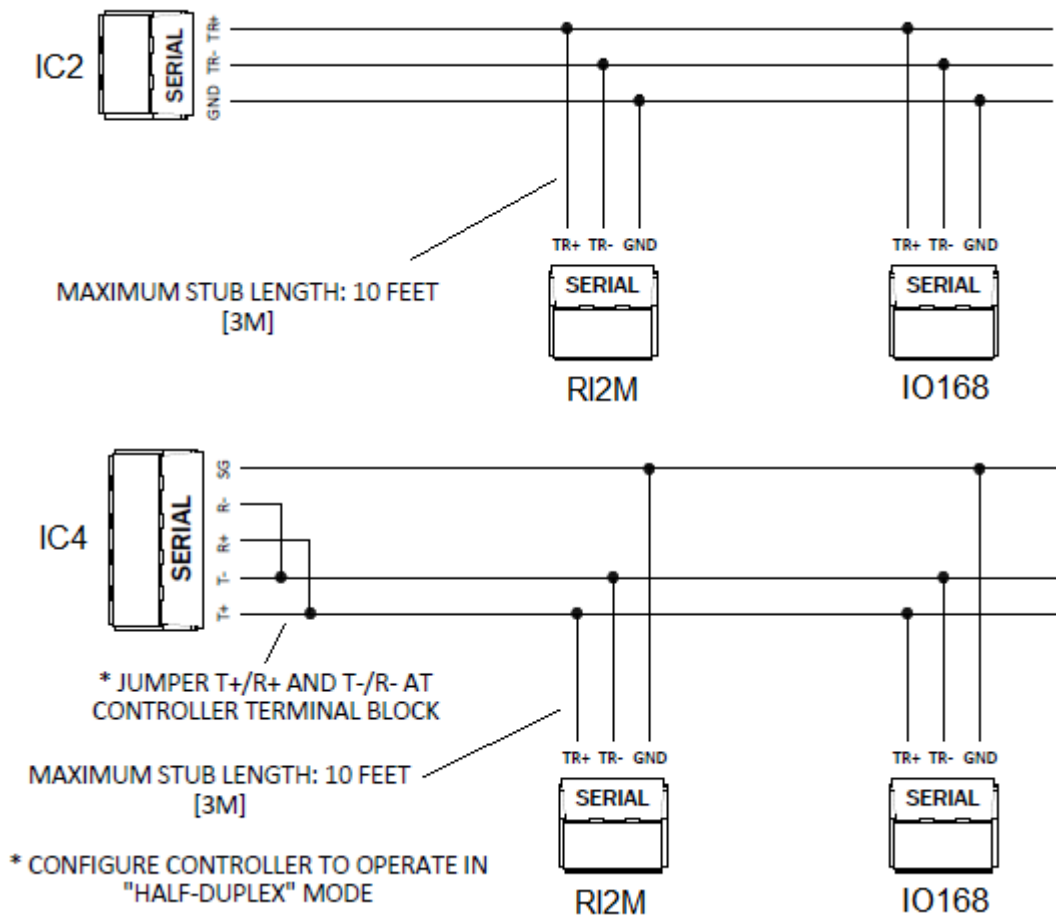

Figure 3.1 RS-485 Device Connections

3.2.2 Bus Configuration

The maximum number of field devices on one RS-485 communications bus is 32. Communication cables for RS-485 should be laid out in a "multi-drop topology". This means that there should only be two ends to the line and devices should be located directly along this line. The RI2MS can be located at any point along the line. Long stubs (T connection) and Star Topology will cause communication problems and must be avoided. Each field device must have a unique address, and all the devices must use the same baud rate. All devices on the RS-485 bus must be communicating with the same protocol.

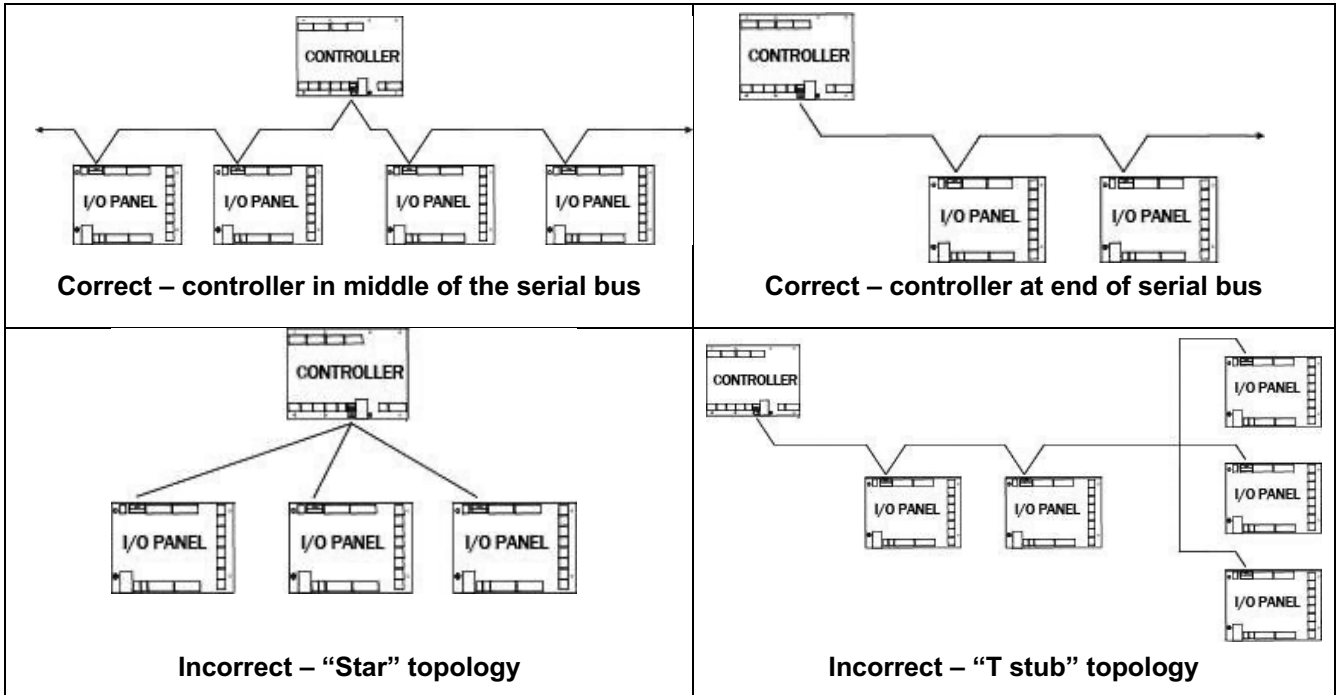

Figure 3.2: RS-485 Bus Topologies

3.2.3 Termination

For the most reliable communications, the RS-485 bus must be terminated at both ends. The terminators are integrated on the board and are engaged via user installed jumpers. Never engage termination of devices in the middle of the communication bus.

3.2.4 Signal Ground (SG)

When devices are powered from different power supplies, a common ground reference must be established on the RS-485 bus. This is the ground (GND) connection on the Serial port connector. Failure to have a common ground between devices may cause communication errors. If connecting the RS-485 bus with shielded wire, the shielding can be used as the signal ground connection. Or, if the environment is known to be electrically noisy, the wire's shield can be connected to safety/chassis/Earth ground and a separate wire can be used for signal ground.

Grounding Potential Difference Checks Before Connecting

Before a device is connected to an RS-485 subsystem, it must be checked for ground fault. Ground faults can damage all devices connected to the RS-485 communication line. To check if there is ground fault for a new unit, follow the steps below:

1. Apply power to all devices already successfully connected to the RS-485 line.
2. Power up the new unit, but DO NOT connect it to the RS-485 line.
3. Connect the signal ground (SG) of the RS-485 line through a 10k limiting resistor.
4. Measure the AC and DC voltage across the resistor. There should NOT be more than 1 volt across the resistor. Otherwise find and clear the fault.
5. Connect the new unit to the RS-485 line only if no ground fault is found.

3.3 Unsupervised Cabinet Tamper & Power Fault (TB8)

The RI2MS provides two dedicated, unsupervised alarm inputs; cabinet tamper and power fault. Use a twisted pair of 24 AWG wires. These are typically Normally Closed inputs. When not in use, a jumper wire should be used to short the contacts together created a closed circuit. This will prevent inadvertent alarms being reported to the Host.

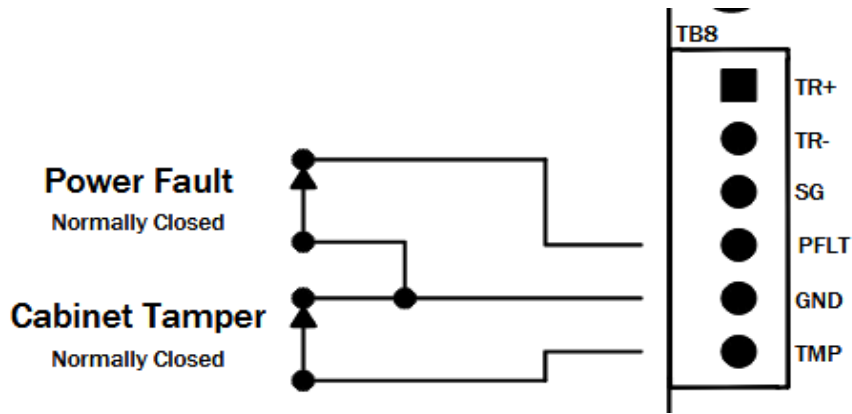

Figure 3.3: Cabinet Tamper & Power Fault Wiring

Note: Even though PFLT and TMP share a GND connection, both inputs will report separately during normal operation. However, if the shared GND connection comes loose, both a PFLT and TMP alarm will be reported simultaneously.

Cabinet Tamper – This input is designed to be connected to the system’s enclosure door and will send an alarm signal when the enclosure is opened/tampered with.

Power Fault – This input is designed to be connected to an output on a power supply that supports power fault alerts. When a power supply problem is detected, the output signal will become “Open”. A power fault alarm should activate any backup power available.

3.4 Reader Ports (TB6 & TB7)

The RI2MS has two onboard reader ports that support both TTL (Wiegand, Clock & Data, etc) and RS-485 (OSDP) readers. The RS-485 reader bus is a true RS-485 port, meeting all requirements of the electrical standard.

PIN	DESCRIPTION
GND	Ground connection for the reader
DAT/D0 & CLK/D1	TTL or RS-485 reader data connections (see 3.5.1 and 3.5.2 below).
BZR	Open-collector buzzer output. Can also be used for 2-wire LED control
LED	LED control signal
RVO	12VDC VIN passthrough or to power reader

3.4.1 TTL Readers

Each reader port on the RI2MS can support one TTL reader. TTL reader types include Wiegand, magnetic stripe, proximity, bar code, smart card, biometric, keypad, etc. A different type of reader can go on each port.

TTL readers usually utilize all pins on the reader port. The wiring to a TTL reader should be made using 24 AWG minimum, shielded cable with 6 conductors (Belden 9536 or equivalent). Do not exceed 500 feet (152 m) between the RI2MS and reader. 18 AWG cable may be required for long cable lengths or for large current requirements. If twisted pair cable is used, do not wire Data 1/Clock and Data 0/Data in the same pair. Connect the shield drain wire of the cable at the GND terminal of the appropriate reader connector on the RI2MS. Carefully insulate the drain wire with sleeving for a reliable installation.

Power for each reader port is provided through the “RVO” pins. Power supplied on RVO is a passthrough of VIN (12 VDC). Each reader port can supply 500mA. If the readers have a greater total power requirement, or if there are other wiring concerns, external power supplies should be used to power the readers. In this case, only connect the reader power lines to the external power supply; do not connect the reader to two power supplies.

For basic operation of the reader, at a minimum the Data 1/Clock and Data 0/Data wires must be connected from the reader to the RI2MS and power supplied to the reader. LED and beeper control lines do not have to be connected, but in this case, the LED and beeper may not function on the reader.

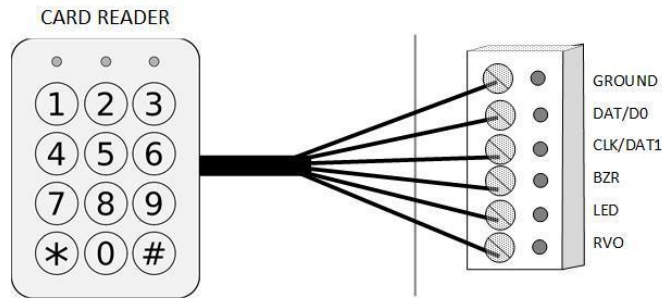

Figure 3.4: TTL Reader Wiring

3.4.2 RS-485 (OSDP) Readers

Both reader ports on the RI2MS can communicate with RS-485 readers; OSDP being the most popular. The Reader Port is a true RS-485 port meeting TIA-485-A. Currently only one OSDP reader is supported on each reader port with the address of 0 (zero) and a 9600 baud rate.

As of firmware version 1.25, the address and baud rate to the connected readers are configurable and readers can also be configured to use OSDP Secure Channel encryption.

RS485 readers (OSDP) use a 2-wire interface (transmit and receive on same wires). Always observe polarity of the lines; connecting positive (TR+) to D1 and negative (TR-) to D0. When powering the reader from an external power supply, it is still required to connect the reader's Ground or Signal Ground to the GND connection on the reader port for reliable communications. “Star” wiring or “T stubs” longer than 10ft must never be used!

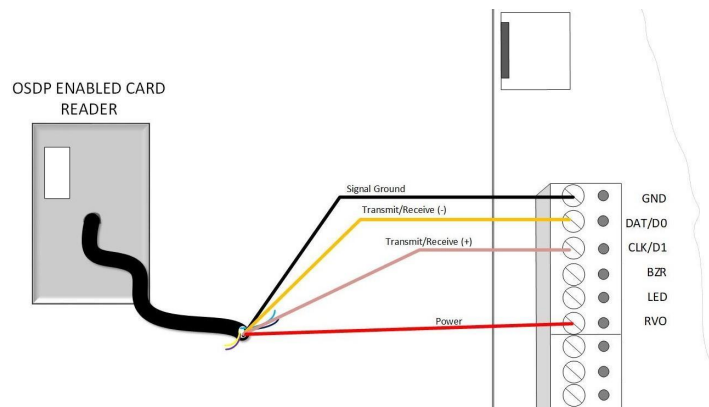

Figure 3.5: OSDP Wiring

3.5 Supervised Alarm Inputs (TB1 & TB2)

The RI2MS has 6 Supervised Alarm Inputs. These inputs are multi-purpose and are configured with the Host software. Any input can be assigned as a door contact, REX, or auxiliary alarm input (i.e. motion or glass-

break sensors). With the use of end-of-line termination resistors, the alarms are monitored for not only secure and alarm states, but also the detection of fault conditions from tampering and accidental damage.

The inputs of the RI2MS are monitored to detect a change of state. The inputs can be set to be “Normally Open” or “Normally Closed”. There are two input modes...

Supervised: With the use of end-of-line termination resistors, the alarms are monitored for not only secure and alarm states, but also the detection of fault conditions from tampering or accidental damage.

Unsupervised: Two states (alarm and secure) are monitored by the RI2MS by checking for an open or closed-circuit input signal. Because tampering or damage can go undetected, this is the least secure input configuration and should not be used for important sensors. See Figure 3.6.1 for wiring example.

For cabling recommendations, see the Specifications section.

3.5.1 End of Line (EOL) Termination Resistors

Using two End-of-Line (EOL) termination resistors, the Supervised mode can detect fault conditions resulting from accidental damage or tampering. The RI2MS will not confuse this condition with a valid secure or alarm condition. For maximum security, the end-of-line termination resistors should be placed at the END of the cable, farthest away from the RI2MS.

There are multiple EOL options, ranging from ready-made terminal block connectors to individual, hand-placed resistors. The EOL resistor values is configured in the Host software. The pre-defined EOL options are as follows...

- 300 / 10K Ohms
- 1K / 2K Ohms
- 3.4K / 4K Ohms

The following wiring diagram shows some of the pre-defined termination resistor configurations. For ease of installation, pre-assembled resistor packs for termination are available; the ATM-30 is 300/10K Ohms & ATM-3D is 3K/4.5K Ohms.

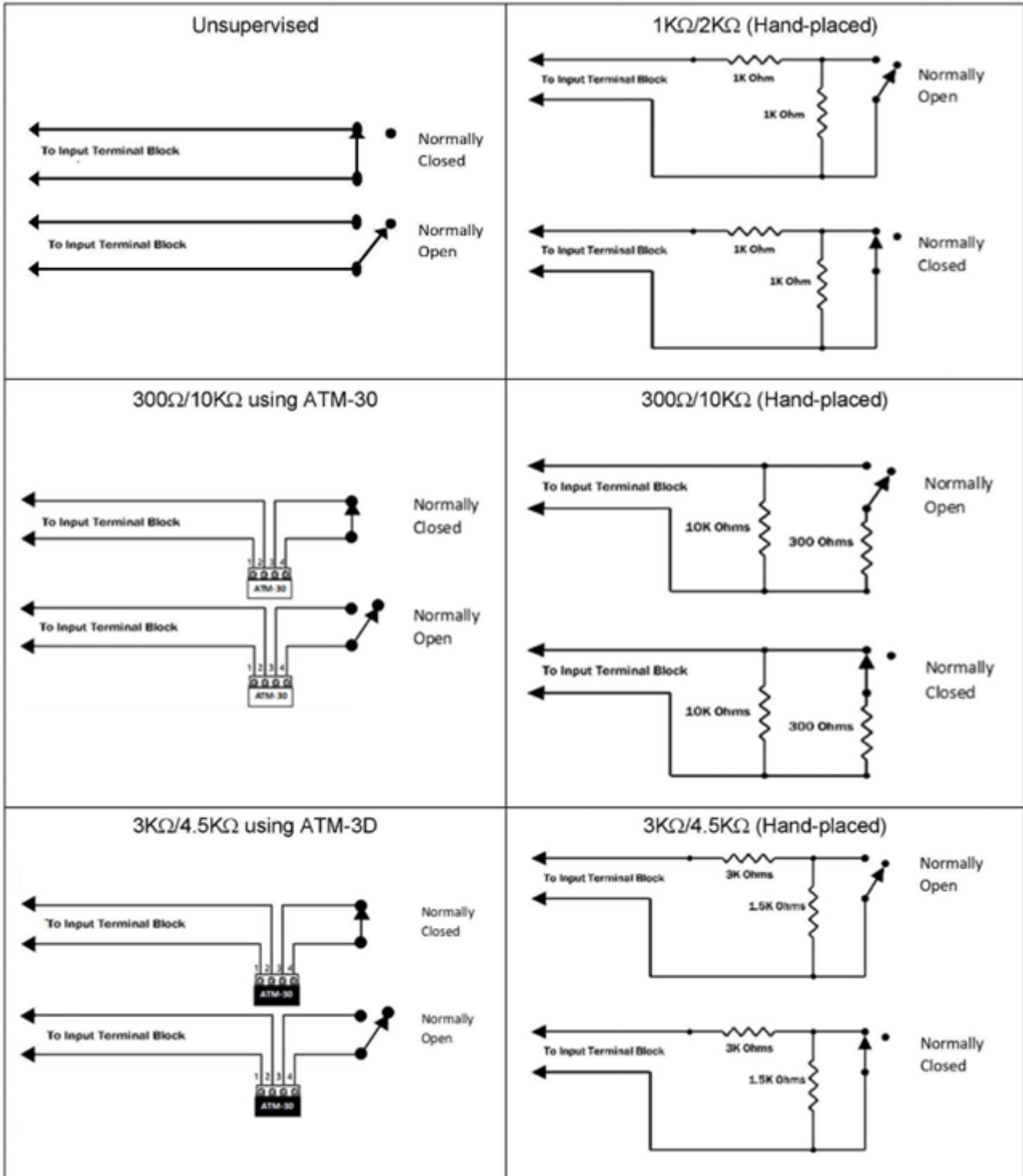

Figure 3.6: Input Supervision

3.6 Output Relays (TB4 & TB5)

The RI2MS has four output relays onboard. These relays can either control a door strike (lock) or other electrical device connections or other miscellaneous output control. Relay functions are defined in the Host software. The onboard relays can switch up to 2A @ 30VDC or 0.5A @ 120VAC.

3.6.1 Door Strike Wiring

A typical electric door strike (lock) will require around 250mA (0.25 Amps) to operate. If the locking device requires more than 2 Amps to control, another external power-switching device/relay of adequate power rating must be used. Some strikes such as magnetic strikes are inductive loads, in which case is recommended to derate the relay's rated current by 50%.

Wiring between the strike power supply, strike relay (internal or external) and the electric lock should be of sufficient gauge (16 to 18 AWG recommended) to prevent excessive voltage drop under all circumstances.

The strike can be wired in a fail-safe (door unlocks on power outage) or fail-secure (door locks on power outage) manner by using either the Normally Closed (NC) or Normally Open (NO) relay contacts.

3.6.2 Auxiliary Output Relay

Aside from controlling door strikes, relay outputs can be used for controlling other audible and visual devices. Auxiliary relay functionality is configured via the Host software.

3.6.3 Voltage Spike Suppression

Due to inductive nature of a door strike, energizing and deenergizing of the relay can cause voltage spikes across the relay contacts. If no suppression is used to defend against these voltage spikes, communication problems and permanent damage to the hardware may occur.

Strike Type	Suppression Method
DC Strike	Reverse-biased DIODE with a continuous current rating of at least 1x the strike current and a breakdown voltage (Vbr) rating of at least 2x the strike voltage. Usually a 1N4001 – 1N4006 will work.
AC Strike	A Metal Oxide Varistor (MOV) will usually be included with the strike. If a MOV does not come with the strike, contact the strike manufacturer for the appropriate MOV ratings. Be sure to use a UL approved MOV.

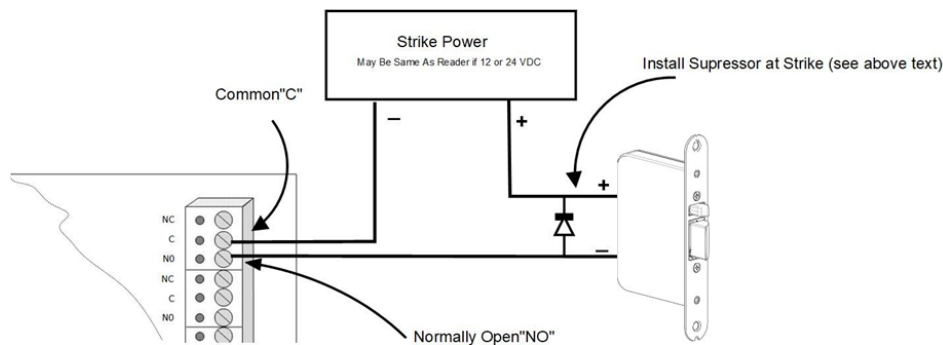
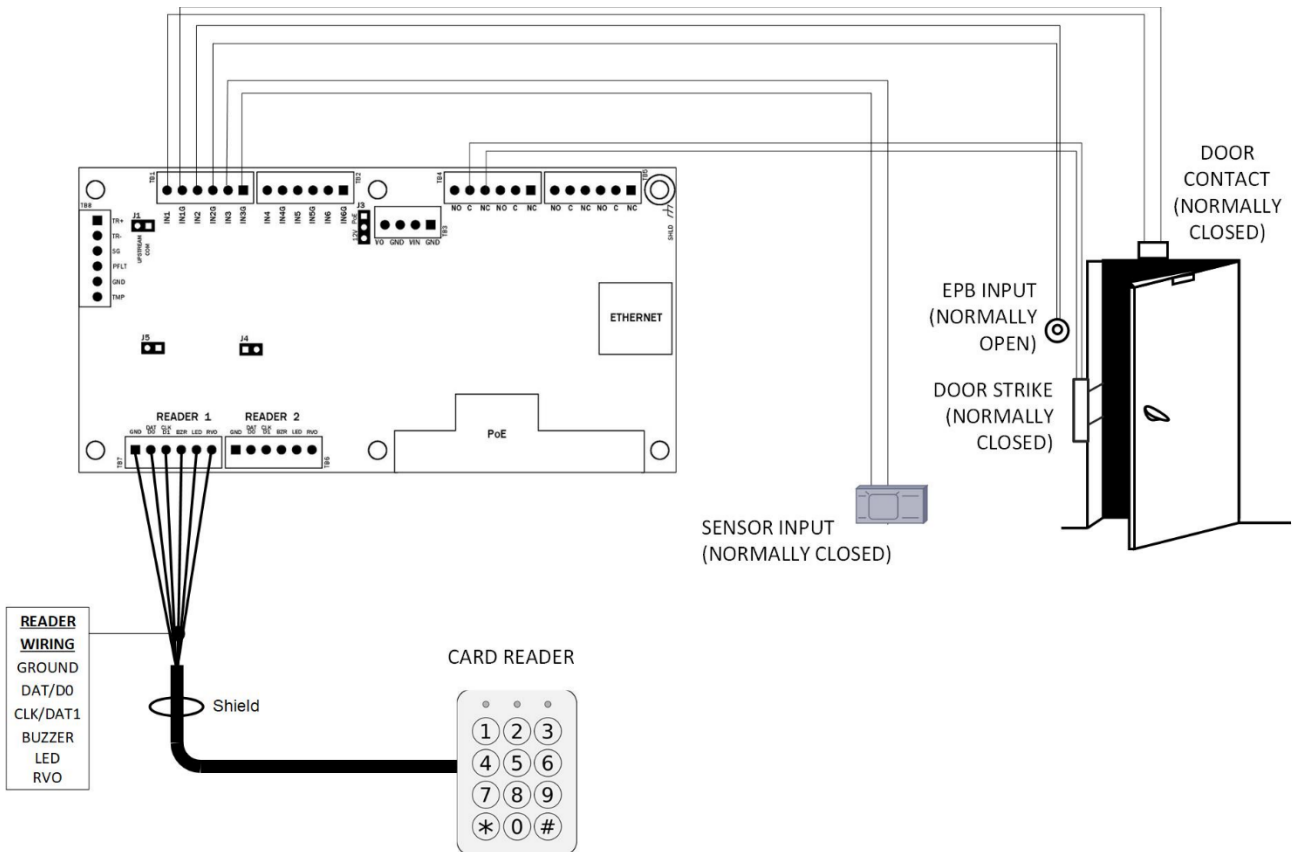

Figure 3.7: Strike Wiring Diagram (DC w/ Diode)

Both DC or AC suppression components are placed across the output device's electrical terminals.

3.7 Door / Access Point Setup

An Access Point (sometimes referred to simply as "Door") is the grouping of at least one reader, supervised inputs, and relay outputs to yield full control and monitoring of a door/entryway. A "complete" Access Point consists of at least one reader, two supervised inputs (for door contact and REX), and one relay output controlling the door strike. The RI2MS supports 2 complete Access Points with onboard interfaces. Configuration and assignment of the Access Point's interfaces is done through the Host software. Recommended connections are listed in the Terminal Block table in section 2.



Part IV

Operation

4 Operation

4.1 Firmware

Firmware can be updated in the field via the Host and controller, or with the “Debug Tool” desktop application.

4.1.1 Gen2 vs Gen3

The firmware file that can be loaded to the board depends on the “Generation” of the board which is related to the board revision. Board revisions A through C are considered Gen 2 and board revisions D and later are considered Gen 3. The board Generation is reported in the “Model” field in the ID Report. If the incorrect Generation firmware is sent, it will be rejected. Firmware features are consistent for both generations.

Gen 2 – Does not support TLS or HTTPS and must rely on OSDP Secure Channel for encrypted coms

4.1.2 Bootloader

Underneath the application firmware is the bootloader that handles firmware updates. When the board is running in the bootloader, the TMP and PFLT LEDs will alternate blinking. If a firmware download fails, the board will continue running in the bootloader until firmware can successfully be downloaded and applied.

As of bootloader version 1.25, baud and address set during application runtime will persist in the bootloader.

4.2 Serial COM Configuration

The address and baud rate can be set with DIP switches or with OSDP commands via software. DIP switch 8 turned OFF will use OSDP command settings, and DIP 8 ON will use the DIP switch settings.

As of firmware version 1.25 the baud rate of 230400 is supported for communicating with the controller, but can only be set with software command, not DIP switches.

DIP switches 1-5 to set the Physical Address and 6 & 7 to set the Baud Rate. After switching to DIP switch-set address and baud rate, a previous software-set address and baud rate will be retained and used if DIP switch 8 is turned back OFF (see DIP function table in section 2.4).

Note: All devices on the serial bus must use the same baud rate. Each device needs to have a unique address.

4.2.1 Serial COM Encryption

Serial communications to the controllers can be encrypted using OSDP Secure Channel (AES). Both default keys and custom keys are supported. Once an encryption key is sent to the device, encrypted communications are automatically enabled.

As of Firmware 1.25, Secure Channel with custom keys can be used to encrypt communication to attached OSDP readers.

If communication is broken to the controller due to a controller resetting and losing the encryption key, the encryption key can be cleared using DIP switch 11 (see DIP function table in section 2.4). Note that using DIP 11 will also clear custom keys used to communicate with the OSDP readers.

4.3 Offline Mode (Firmware 1.23)

When the RI2MS cannot communicate with the controller, it can still operate in “Offline Mode” with limited access control functionality. Offline Mode is configurable and uses local hardware interfaces that are linked together.

4.3.1 Offline Events

Events that occur locally while the RI2MS is not communicating with the controller are stored and then reported to the controller when communications are restored. Events are stored in non-volatile memory, so loss of power to the board will result in a loss of the stored offline events.

4.3.2 Configurable Offline Modes

ANY CARD MODE: Any readable card presented to the reader will unlock the assigned strike.

FACILITY CODE MODE (Firmware 1.24): Cards presented to the reader with the authorized facility code will unlock the assigned strike.

UNLOCK or LOCK MODE: A strike can be configured to be permanently locked or unlocked when offline.

REX UNLOCK: Activating the "REX" input will unlock the assigned strike

PART V

Troubleshooting

5 Troubleshooting

5.1 Serial RS-485

- Verify DIP switch setting for baud rate and communication address:
 - All devices on the communication port **MUST** use the same baud rate
 - Each device on the communication port **MUST** have a unique address
- Check proper voltage on the RS-485 line (-7 to +12VDC). If values are out of range, check termination and grounding.
- If a serial communication encryption key has been sent, automatically encrypting communications, losing the communication key on the controller will require clearing the encryption key with the DIP switch on the board (see section 2.4). Very few messages can be received unencrypted when encryption is activated.

5.2 Alarm Device Input

If zones report fault (in supervised mode), check the resistance of the line. The resistance should not exceed +/- 15% of the EOL value used. The entire loop wiring resistance must not exceed 30 ohms. Improper wire gauge may create increased resistance and therefore false faults on the line.

5.3 Output Relays

If the device attached to the relay is producing the opposite result than expected (e.g., siren turns off when should turn on), wire the device to the opposite pole than which it is currently connected (NC to NO). If relays are not switching properly, check the power load which is not to exceed 2A @ 30Vdc. Check the polarity of the suppression diode.

PART VI

Specifications

6 Specifications

Specifications are subject to change without notice.

Primary Power (VIN)	<p>DC/DC: 12VDC \pm 10%</p> <ul style="list-style-type: none"> Board operating current: 190mA max Full-load (powering VOUT & RVOs) current: 2.19 Amps max
Auxiliary Power (VOUT)	VIN Passthrough 12VDC; 1000mA (1 Amp) max. Add to VIN current
Reader Power (RVO)	VIN Passthrough 12VDC; 500mA max each port. Add to VIN current
Network Com (x1)	10BaseT/100Base-TX Ethernet
Upstream Serial Com (x1)	RS-485; 2-wire (half-duplex), 9600 to 115200 baud; 32 available addresses
Tamper & Power Fault	Unsupervised digital inputs for cabinet tamper and power supply failure
Alarm Inputs (x6)	Unsupervised or Supervised, configurable End-Of-Line resistor values. 1K/2K, 3K/4.5K, 300/10K are default, custom values available. Use 1%, ¼ Watt resistors
Output Relays (x4)	<p>Dry, Form-C contacts; 2A @ 30VDC / 0.5A @ 120VAC max</p> <p>Note: When connecting an inductive load like a magnetic strike, it is recommended to derate the relay's current rating by 50%</p>
Reader Ports (x2)	<p>Reader Power: See "Reader Power (RVO)" above</p> <p>Data Input: Supports F/2F, TTL (Wiegand or Clock/Data), and 2-wire RS-485 (9,600 to 115,200 baud) for OSDP readers.</p> <p>Buzzer Output: Open collector; 18 VDC max; sink 50mA max.</p> <p>LED Output: Tri-State LED output; Active Low; 20mA source or sink max; TTL logic levels (High > 3V & Low < 0.5V)</p>

Cable Requirements	<p>DC Power: 18 AWG minimum; 1 twisted pair</p> <p>RS-485: 24 AWG; 1 shielded twisted pair; 4000 ft. (1,219m) max @ 9600 baud; Belden 9841 or equivalent cable</p> <p>Reader Data (TTL): 4 to 6 wires; 500 ft. (152 m) max; 18 to 22 AWG depending on cable length; non-twisted pairs. For 6-conductor wiring, Belden 9536 or equivalent is recommended.</p> <p>Inputs: 1 twisted pair; 30 Ω max loop resistance; 24 AWG for 0-500ft loop, 22 AWG for 500-1000ft, 20 AWG for 1000-2000ft</p> <p>Relay outputs: 16 to 18 AWG. Use sufficient gauge to avoid voltage loss.</p>
Environmental	<p>Temperature: -40 to 85°C operating and storage; Indoors</p> <p>Humidity: 5 to 95% RHNC.</p>
Mechanical	<p>Dimensions: 5.4 in. (137.16 mm) W x 2.75 in. (69.85 mm) L x 0.75 in. (19.05 mm) H</p> <p>Weight: 0.28 lbs. (126 grams)</p>

PART VII

Revision History

7 Revision History

Rev	Date	Description of changes	Editor
A1	3/28/2022	Initial draft	Evan Z
A2	5/18/2022	Pre-release content update and formatting fixes. Fix baud rate DIP table.	Evan Z
A3	6/10/2022	Fix spec of number of readers allowed on each reader port	Evan Z
A4	6/30/2022	Update images and update OSDP reader section	Evan Z
A5	8/4/2023	Release of new board revision using new MCU <ul style="list-style-type: none"> • Update image of board layout with new board revision • Add serial bus device wiring diagram Fig 3.1 • Update FACTORY RESET DIP switch operation • OPERATION <ul style="list-style-type: none"> • Describe bootloader function and LED indication • Specify difference between previous MCU and newer revision MCU firmware • Update web server information • OSDP Secure Channel • Offline Mode • Network encryption with OSDP Secure Channel • Remove UDP Host List – no longer supported • TROUBLESHOOTING <ul style="list-style-type: none"> • Recover from loss of OSDP Secure Channel encryption key • Update specifications table 	Evan Z
A6	5/8/2024	Update for firmware 1.25 <ul style="list-style-type: none"> • Attached OSDP readers' address and baud rate are configurable • OSDP Secure Channel with custom keys supported for communicating with attached OSDP readers • Bootloader retains application-set baud rate and address • Support for 230400 baud using config command 	Evan Z
A7	???	Update for firmware 1.26 <ul style="list-style-type: none"> • Update topology diagram • OSDP Verified to Secure Profile • NETWORK (section 4.3) <ul style="list-style-type: none"> • New web server layout • DHCP and DNS now supported • Incoming and outgoing connections • Gen 3 boards support TLS 1.3 with custom certificates • Gen 3 boards support HTTPS web server connections • Section 6 – Add total power budget @ 12VDC 	Evan Z