



M12 POE Switch 24VDC User Manual

Table of Contents

FCC Marking.....	2
CE Marking.....	2
Trademarks.....	2
Introduction.....	3
Features.....	3
Housing Dimension.....	3
Installation package.....	4
Power connection.....	4
LED indicator.....	5
Specification:.....	6

FCC Marking

This Equipment has been tested and found to comply with the limits for a Class A digital device, pursuant to part 15 of the FCC Rules. These limits are designed to provide reasonable protection against harmful interference when the equipment is operated in a commercial environment. This equipment generates, uses, and can radiate radio frequency energy and, if not installed and used in accordance with the instruction manual, may cause harmful interference to radio communications. Operation of this equipment in a residential area is likely to cause harmful interference in which case the user will be required to correct the interference at his own expense.

This device complies with Part 15 of the FCC Rules. Operation is subject to the following two conditions: (1) this device may not cause harmful interference, and (2) this device must accept any interference received; including interference that may cause undesired operation.

CE Marking

This equipment complies with the requirements relating to electromagnetic compatibility, EN 55032/24 class A for ITE, the essential protection requirement of Council Directive 2014/30/EU on the approximation of the laws of the Member States relating to electromagnetic compatibility.

Company has an on-going policy of upgrading its products and it may be possible that information in this document is not up-to-date. Please check with your local distributors for the latest information. No part of this document can be copied or reproduced in any form without written consent from the company.

Trademarks

All trade names and trademarks are the properties of their respective companies. Copyright © 2018, All Rights Reserved.

Introduction

This rugged designed M12 Industrial Ethernet POE switch has passed many rigorous environmental tests. It comes with 8 x M12 connectors for Power, Relay, Data and POE. It is exclusively designed for Transportation environment to enhance your security application. With a built-in voltage booster feature, it can be power up with 24VDC input in -40°C to 75°C harsh environment.

Features

- M12 Rugged Industrial 6 port 10/100M POE switch
- With 4 x 10/100M M12 PSE (IEEE802.af/at 30W) + 2x10/100M M12 (data)
- Power input VDC 24-56 with voltage booster
- Operating temp: -40°C to +75°C

Housing Dimension

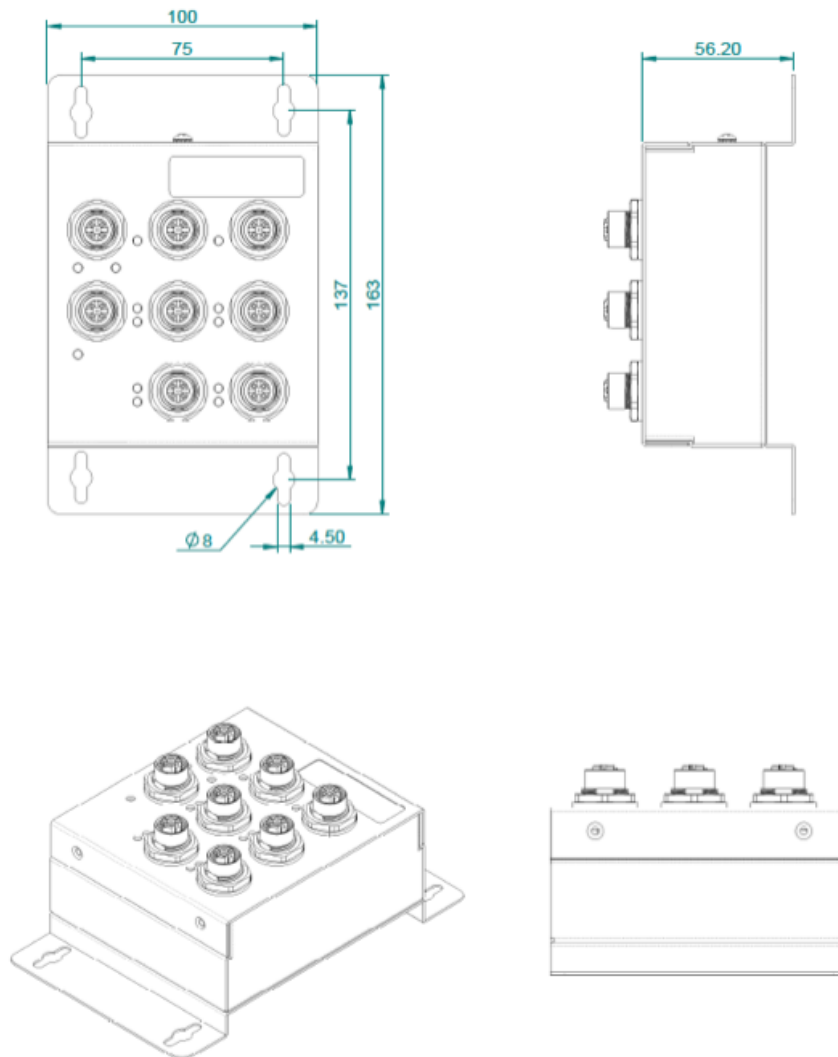

NOTE:

Housing dimension is for purpose of showing product Length, Width, Height, din-rail, and terminal block's position and dimension. Please refer to the LED Indicator Page for correct port order.

Installation package



Power connection

This M12 POE switch needs M12 power connector to power up this device. When connecting with power source, make sure the polarities are correct to match the voltage definition as below:

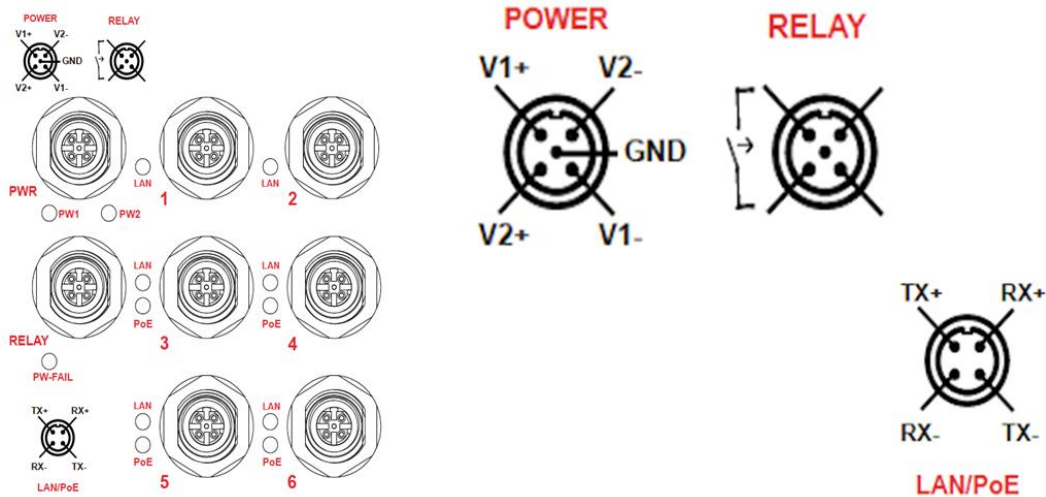

This unit is equipped with voltage booster feature. Its POE power can be operated with 24VDC input (24 - 56VDC range). Always make sure your input voltage is within this supported voltage range for this unit.

WARNING – any exceeded input voltage will not make this unit function and may damage this unit.

To make power connection – Follow the printed polarity for V1+, V1-, V2+, V2-, and ground. Connect positive wire to V +, connect negative wire to V-, also connect neutral wire to the ground as shown .

Relay -- You may use 24V@1A relay connection to your external device for special purpose. When 2 powers are connected, the relay is in OPEN mode. The PW-FAIL LED will stays "OFF". When only 1 power source is connected, the PW-FAIL LED will stays "ON".

WARNING:

Always ground the power source to maintain a clean power input. Cheaply made power supplies create too much noise and will cause the power input to fluctuate when connected to this unit. To avoid this, always ground the power source to maintain a clean power input.

LED indicator

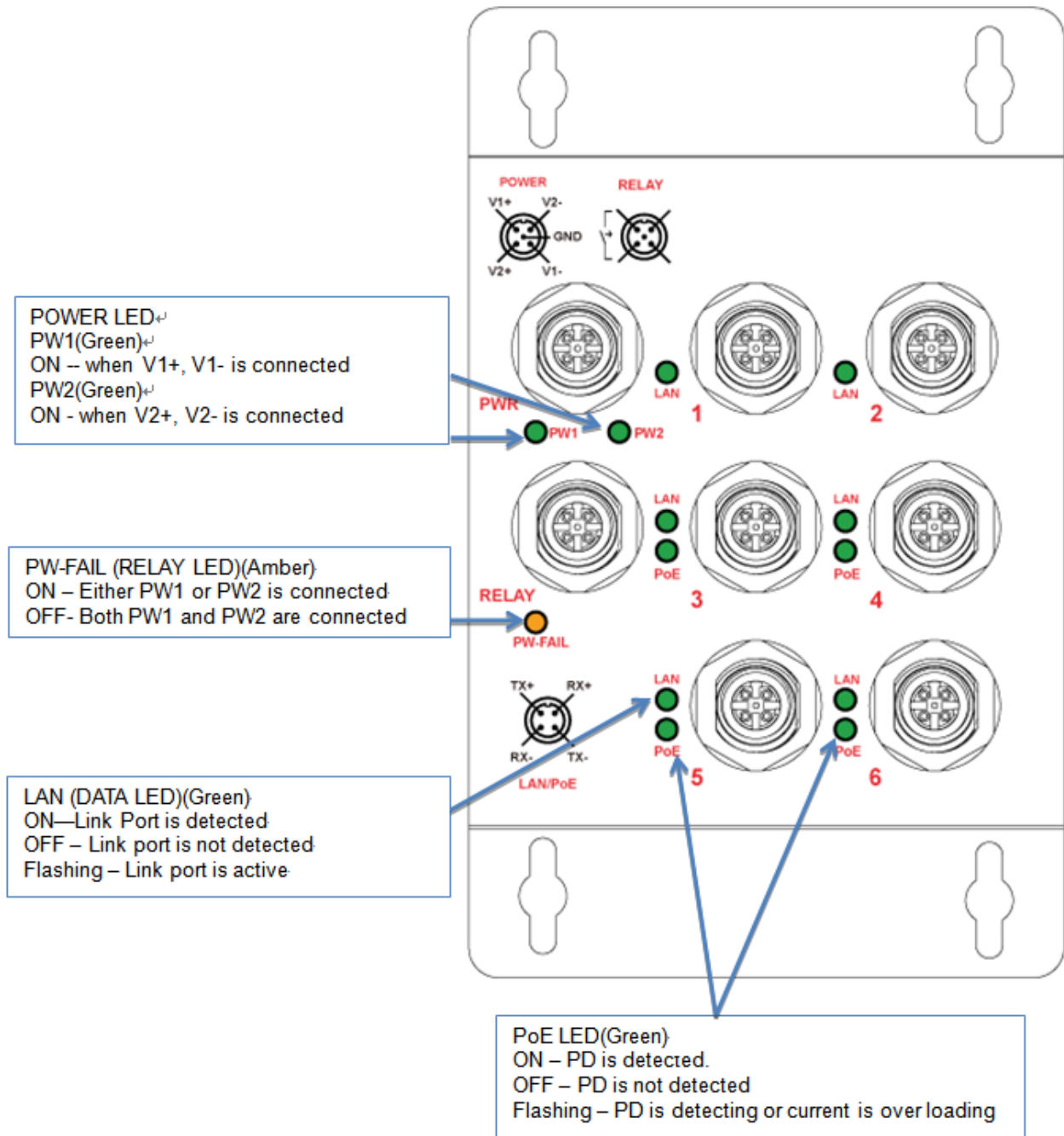

Specification:

IEEE Standard	IEEE 802.3 10Base-T Ethernet with M12 connector IEEE 802.3u 100Base-TX Fast Ethernet with M12 connector IEEE802.3x Flow Control and Back Pressure, IEEE802.3af for POE IEEE802.3at for POE+
Switch Architecture	Back-plane (Switching Fabric): 1.2Gbps
Data Processing	Store and Forward
Flow Control:	IEEE 802.3x Flow Control and Back Pressure
MAC address Table Size	1K
Packet Buffer Size	1M
Network Interface	6xM12 10/100BaseT(X) auto negotiation, 4 x M12 10/100M POE+ 802.3at/af PSE port, 2 x M12 10/100M port Auto MDI/MDI-X function, Full/Half duplex
Network Cable	UTP/STP Cat.5e or above Cable
	EIA/TIA-568 10-ohm (100m)
Protocol	CSMA/CD
LED	M12 PW1(Power 1) Green, M12 PW2(Power 2) Green, RLY(Relay) Amber,
	M12 port: Green --- LAN (Link/Active) Green --- POE link
Reserve polarity protection	Present
Overload current protection	Present
Power Supply	Redundant Dual DC 24V-56V Power Input,
Power Consumption	3.76W@48 VDC full load, Without POE 30Watts per POE port, Max 126W @ 24VDC full load with POE
Alarm Relay Contact	Relay outputs with current carrying capacity of 1 A @24VDC, Relay in open circuit mode when 2 powers are connected. In short circuit mode when only one power supply is connected
POE power	Input Voltage 24VDC-56VDC.
Operating Temperature	-40°C to 75°C

Operating Humidity	5% to 95% (Non-condensing)
Storage Temperature	-40°C to 85°C
MTBF (mean time between failure)	510,304 hours (MIL-HDBK-217F) at 25°C
Housing	Rugged Metal, IP40 Protection
Case Dimension (L x W x D)	163 x 100 x 56.2 mm (L x W x D)
Installation mounting	Wall Mount included
Certification	
Safety	LVD(EN60950-1)
EMC	CE, FCC, EN 55032/24
EMI	CISPR 32, FCC Part 15B Class A
EMS	IEC 61000-4-2 ESD: Contact: 6KV; Air: 8KV IEC 61000-4-4 EFT: Power: 2KV; Signal: 2KV IEC 61000-4-5 Surge: Power: 2KV; Signal: 2KV
Vibration	EN 60068-2-6
Shock	EN 60068-2-27
Free Fall	EN 60068-2-32
Railroad	EN 50155 / EN 50121-3-2
Railroad	EN 50155 / EN 50121-4