

Quick Start Guide

(8200-2007-01_E)

Illustra Pro Gen4 2MP & 8MP IR PTZ Outdoor camera
(P/N IPS02-P24-OI04 & IPS08-P25-OI04)

In the box

- 1 x Illustra IR PTZ Camera
- 1 x Printed Quick Start Guide
- 1 x Printed Regulatory Document
- 1 x NTSC/PAL output female BNC cable
- 1 x 2-pin European style terminal block
- 1 x Torx 20 security L-Key & 1 x Torx 10 security L-Key
- 1 x 12-pin terminal connector for I/O function
- 1 x Safety cable (Pre-attached to the camera)
- 1 x Mount adaptor
- 3 x ¼ 20 UNC security screws
- 1 x Rubber grommet
- 1 x RJ45 Insert tool

Installation tools

- 1 x Screw driver
- 1 x Torx 20 security L-Key & 1 x Torx 20 security L-Key
- 1 x Drill
- 1 x Wire cutters



Table 1: Camera part descriptions

Number	Description
1	NPT Pendant Cap
2	Screw (x2) to open and lock the top cover
3	Top cover
4	SD Card Cover
5	Camera lens
6	Camera head

Quick reference

- Default IP: 192.168.1.168 (DHCP enabled)
- Default Username / Password: admin / admin
- Power: PoE 802.3bt 90w or AC 24V

Note: Before you power up the camera; please ensure that all packaging has been removed, including packaging located inside the bubble assembly. As part of the start-up sequence the camera runs motor calibration, this includes a 15 second 'shake' procedure.

Table 2: Camera interior buttons / connections descriptions

Buttons / Connectors	Description
	AC24V Power connector
	PoE Ethernet port
	Analog out port
	Audio and Alarm pins (See Figure 3 for descriptions)
	Reset to factory default (Hold for 5 seconds and then release)
	Power LED indicator
	Reboots the camera

Figure 1: PG4 IR PTZ camera parts

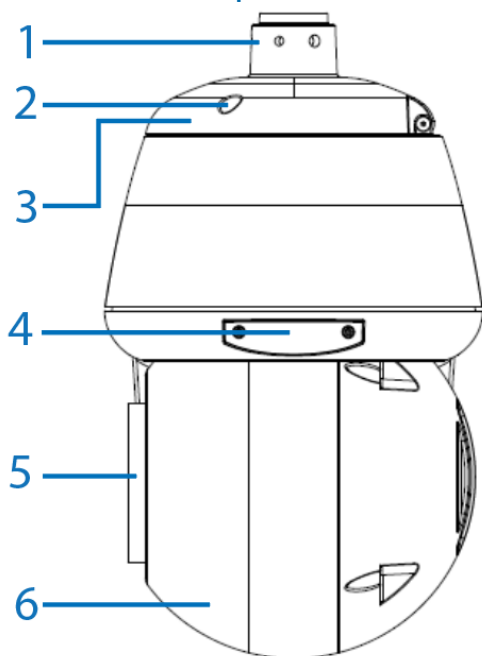

Figure 1

Accessing the camera interior buttons / connections

1. Use the Torx security L-Key to remove the two screws on the camera top cover (1) (Figure 2).



Figure 2

Figure 3: Audio and alarm pin descriptions

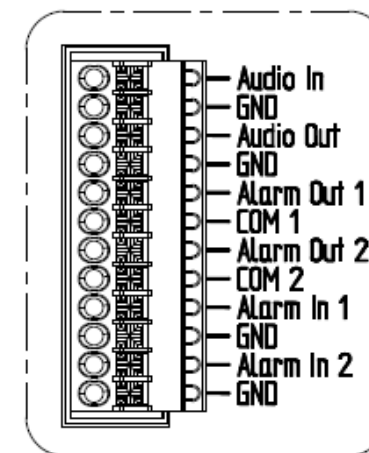

Figure 3

Mounting the camera

Refer to the Illustra mounting accessories webpage <https://www.illustracameras.com/products/accessories/mounts> for assistance. The following mount accessory part numbers are applicable with the Illustra Pro Gen4 2MP and 8MP IR PTZ camera: RHOSW, RHOLW, RHOTR, ROTRF, RHOWCA, ROENDC.

Mounting the camera to the RHOSW accessory

1. Hold the large loop on the safety lanyard (2) (Figure 4) up next to the mounting arm (1) (Figure 4).
2. Ensure that the smaller loop on the safety lanyard is placed around the mounting arm and then through the hole in the larger loop so that the safety lanyard is securely attached to the mounting arm.
3. Remove the safety lanyard screw (3) (Figure 4) on the camera.
4. Place the smaller loop on the safety lanyard around the screw hole on the camera and then insert the screw to securely attach the safety lanyard to the camera.

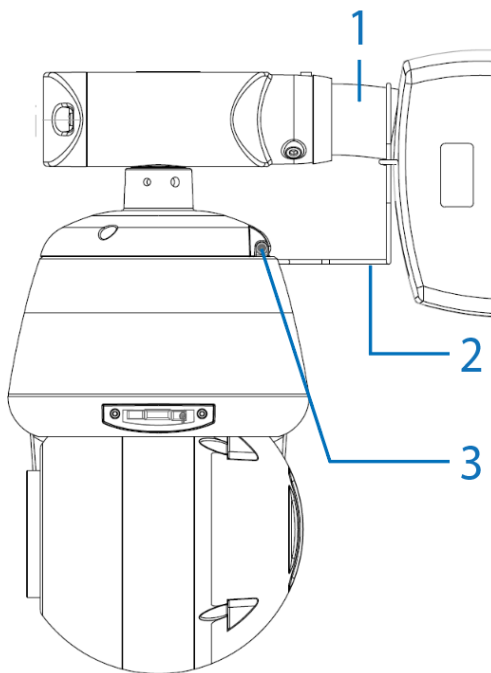

Figure 4

Inserting or removing the micro SD card

1. Remove the two screws located on the micro SD card cover (4) (Figure 1).

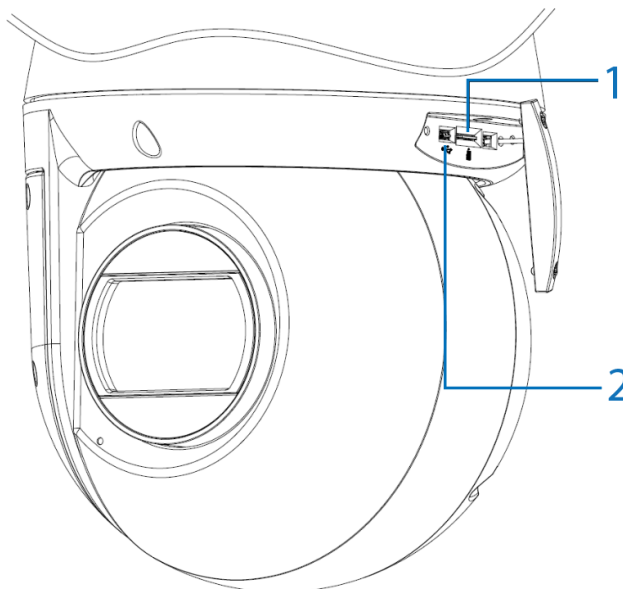

Figure 5

Inserting or removing the micro SD card (continued)

2. Carefully pull open the cover to access the SD card slot (1) (Figure 5) and insert (or remove) the micro SD card into (or from) the camera.
Note: It is advised that you reboot the camera after inserting the micro SD card.
3. Secure the two screws located on the micro SD card cover.
Note: The USB cable connection slot (2) (Figure 5) for Wi-Fi configuration is also located under the micro SD card cover. The Wi-Fi option allows wireless configuration of the camera at the point of install in conjunction with the Illustra Tools app (Illustra Wi-Fi dongle required).

Connecting the wires

This unit supports one of the following options as power supply:

1. Connect a power source.
 - AC24V wired to connector and separate RJ45 Ethernet.
 - OR**
 - PoE through RJ45 connector. The Outdoor unit operates with IEEE 802.3bt (71W max).
2. Connect any optional audio or digital inputs or outputs.
Note: After connecting all cables ensure that the two screws on the top cover are securely attached to maintain the waterproof seal.

Installing the rubber cable seal in to the NPT pendant cap

1. Securely place the rubber cable seal (2) (Figure 5) into the pendant cap (3) (Figure 6).

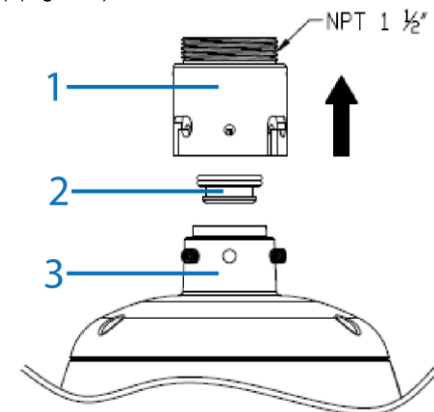

Figure 6

2. Place the mount adaptor (1) (Figure 6) on to the NPT pendant cap (3) (Figure 6) and align the holes on the mount adaptor with the holes on the NPT pendant cap.
3. Insert the three security screws into the three holes and use the Torx security L-Key to securely attach the screws and the mount adaptor to the NPT cap.

Mounting the camera to the RHOSW accessory (continued)

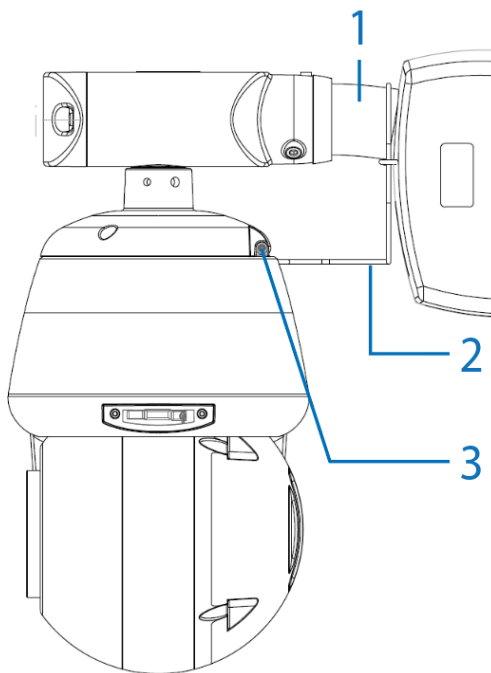

Figure 4

Inserting or removing the micro SD card (continued)

2. Carefully pull open the cover to access the SD card slot (1) (Figure 5) and insert (or remove) the micro SD card into (or from) the camera.
Note: It is advised that you reboot the camera after inserting the micro SD card.
3. Secure the two screws located on the micro SD card cover.
Note: The USB cable connection slot (2) (Figure 5) for Wi-Fi configuration is also located under the micro SD card cover. The Wi-Fi option allows wireless configuration of the camera at the point of install in conjunction with the Illustra Tools app (Illustra Wi-Fi dongle required).

Connecting the wires

This unit supports one of the following options as power supply:

1. Connect a power source.
 - AC24V wired to connector and separate RJ45 Ethernet.
 - OR**
 - PoE through RJ45 connector. The Outdoor unit operates with IEEE 802.3bt (71W max).
2. Connect any optional audio or digital inputs or outputs.
Note: After connecting all cables ensure that the two screws on the top cover are securely attached to maintain the waterproof seal.

Installing the mount adaptor on to the NPT pendant cap (continued)

Note: To maintain the waterproof seal only pierce holes that are required for the installation.

Passing the RJ45 connector through the grommet

1. Remove the plug from the grommet (1) (Figure 7) by pulling the stub (2) (Figure 7) to create a hole in the grommet.

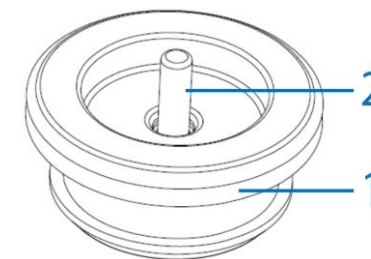

Figure 7

2. Insert the RJ45 cable connector (1) (Figure 8) into the insert tool (2) (Figure 8).
3. Push the insert tool and cable through the grommet hole (3) (Figure 8).
4. Remove the insert tool from the RJ45 connector and pass the cable through the NPT cap (4) (Figure 8).

Passing the RJ45 connector through the grommet (continued)

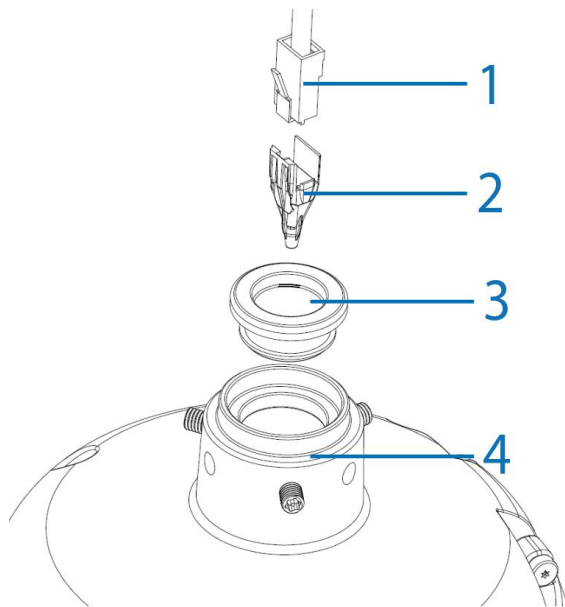

Figure 8

Warnings

1. **Before you power up the camera; please ensure that all packaging has been removed, including packaging located inside the bubble assembly.**
2. Installation and service should be performed only by qualified and experienced technicians and comply with all local codes and rules to maintain your warranty.
3. Wipe the camera with a dry soft cloth. For tough stains, slightly apply with diluted neutral detergent and wipe with a dry soft cloth.
4. Do not apply benzene or thinner to the camera, which may cause the surface of the unit to be melted or lens to be fogged.
5. To meet EU EMC immunity requirements for security equipment the mains power for equipment powering this unit should be backed up by an uninterruptible power supply.
6. When the camera is powered up and not attached to a mount, or unsupported mounts, or if the camera is loose in / on a mount then this may result in motor calibration failure or camera vibration. Motor calibration runs when the camera boots up.
7. Avoid operating or storing the unit in the following locations:
 - a. Near fluorescent lamps or objects with reflections.
 - b. Under unstable or flickering light sources.