

Parapet Mount

SBP-156LMW



Product Features

- ENG** This is a mount used for installing the WN7 Wiper IR PTZ Camera to the surface of a rooftop wall or vertical wall.
(For compatible models, please visit our website.)
- FRA** Il s'agit d'un support utilisé pour installer la caméra WN7 Wiper IR PTZ sur le mur du toit ou sur un mur vertical.
(Visitez notre site Internet, pour les modèles compatibles.)
- GER** Dies ist eine Halterung, mit der die WN7 Wiper IR PTZ-Kamera an der Oberfläche einer Dachwand oder einer vertikalen Wand installiert wird.
(Besuchen Sie für kompatible Modelle, bitte unsere Website)
- SPA** Este soporte sirve para instalar la cámara WN7 Wiper IR PTZ a la superficie de un tejado o pared vertical.
(Para modelos compatibles, por favor visite nuestro sitio web).
- ITA** Questo è un supporto utilizzato per l'installazione della telecamera WN7 Wiper IR PTZ sulla superficie di una parete del tetto o di una parete verticale.
(Per i modelli compatibili, visitare il nostro sito web.)
- RUS** Это крепление для установки камеры WN7 Wiper IR PTZ на стене крыши или иной вертикальной стене.
(Совместимые режимы, см. на нашем сайте.)
- POL** To jest uchwyt przeznaczony do instalacji kamery WN7 Wiper IR PTZ na murze lub ścianie pionowej.
(Wizyta kompatybilnych modelach, proszę odwiedzić naszą stronę internetową)
- TUR** Bu, WN7 Wiper IR PTZ Kamerayı bir çatı katı duvarının ya da dikey duvarın yüzeyine monte etmek için kullanılan bir montaj askıdır.
(Uyumlu modeller için, lütfen web sitemizi ziyaret edin.)
- CZ** Tento montážní úchyt je určen k upevnění kamery WN7 Wiper IR PTZ na povrch střešní nebo svislé stěny.
(Pokud chcete zjistit kompatibilní modely, navštivte naši webovou stránku.)
- JAP** 本製品はWN7 Wiper IR PTZカメラを屋上の壁または垂直の壁に設置する時に使用するマウントです。
(互換性のあるモデルについては、当社ウェブサイトをご確認ください。)
- CHI** 本产品是將WN7 Wiper IR PTZ摄像机安装在屋顶墙壁或垂直墙壁上时使用的安装组件。
(有关兼容型号的信息, 请访问我们的网站。)
- KOR** 본 제품은 WN7 Wiper IR PTZ 카메라를 옥상 벽면 또는 수직 벽면에 설치 시 사용하는 마운트입니다.
(호환 가능 모델은 당사 웹페이지를 참고 바랍니다.)

- W przypadku montażu produktu na zewnątrz należy używać blokad ze stali nierdzewnej.

- Montaj yerinin, Korkuluğa Montaj Dirseği ve Kameranın toplam ağırlığının en az 4 katına dayanabileceğinden emin olun.
- Bu ürün, M8 ankraj civatalarıyla (somunlar) birlikte kullanılmak için tasarlanmıştır.
- Her ankraj civatası, 700 kg güce dayanabilmektedir.
- Ürünü dış mekana kurarken, paslanmaz çelikten yapılmış iç kilit mekanizmaları kullanın.
- Ujistěte se, zda montážní místo unese alespoň čtyřikrát tolik, kolik váží montážní úchyt na parapet a kamera.
- Tento produkt je navržen pro použití kotvevních šroubů a matic M8 při instalaci.
- Každý kotvevní šroub musí být schopen odolat tahu 700 kg.
- Při instalaci produktu ve venkovních prostorách použijte zajišťovací prvky z nerezové oceli.

- 設置場所がパラペットマウント、カメラの総重量の4倍以上を十分耐えられるところに設置してください。
- この製品は、M8アンカー・ボルト(ナット)を使用して設置します。
- 各アンカー・ボルトは、700kgの抜去力に耐えられます。
- この製品を屋外に設置する場合は、ステンレス製の連動装置を使用してください

- 將其安装在可承受栏杆安装组件和摄像机总重量四倍以上的安装地点。
- 本产品设计为使用 M8 固定螺丝(螺母)进行安装。
- 每个固定螺丝都必须能够抵抗 700 公斤拔出力度。
- 在室外安装产品时, 请使用不锈钢制作的联锁装置。

- 설치장소가 파라펫 마운트, 카메라의 총중량의 4배 이상을 충분히 견딜 수 있는 곳에 설치하세요.
- 이 제품은 M8의 양카 볼트(너트)를 사용하도록 설계되어 있습니다.
- 설치된 각각의 양카 볼트는 700kg의 발거력에 견디어야 합니다.
- 옥외에 설치 시 체결류는 스테인레스 재질을 사용하세요.

Package

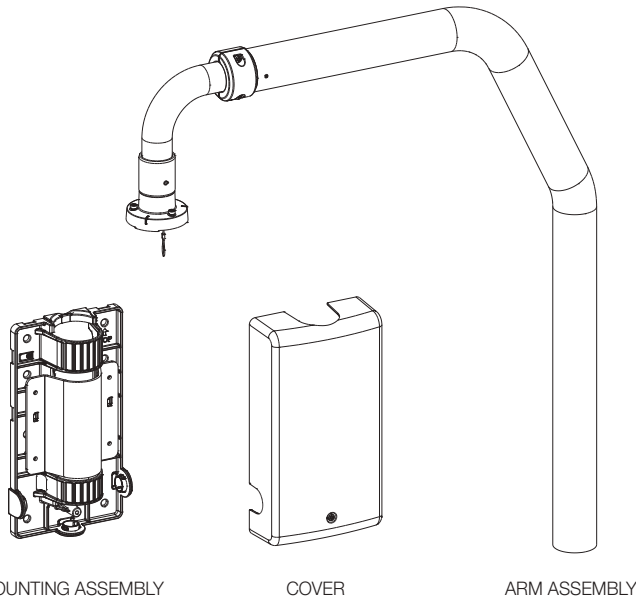

MOUNTING ASSEMBLY

COVER

ARM ASSEMBLY

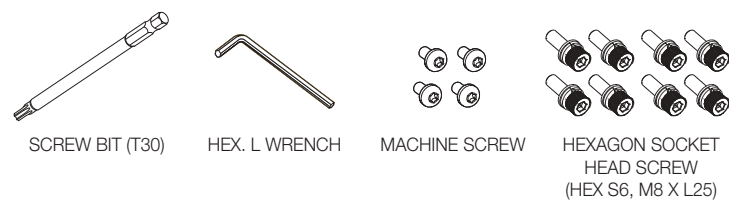

SCREW BIT (T30)

HEX. L WRENCH

MACHINE SCREW

HEXAGON SOCKET HEAD SCREW (HEX S6, M8 X L25)

Installation Precautions

- Make sure that the installation place can endure at least 4 times of the total weight of the Parapet Mount and Camera.
- This product is designed to use M8 Anchor Bolts (Nuts) for the installation.
- Each anchor bolt must be capable of withstanding an extraction force of 700 kg.
- When installing the product outdoors, use interlocking devices made of stainless steel.

- Assurez-vous que le lieu d'installation peut supporter au moins 4 fois le poids total du support de fixation du parapet et de la caméra.
- Pour installer ce produit, vous avez besoin de boulons d'ancrage M8 (écrous à river).
- Chaque boulon doit pouvoir résister à une force d'extraction de 700 kg.
- Si vous installez le produit à l'extérieur, utilisez des dispositifs de verrouillage en acier inoxydable.

- Bitte stellen Sie sicher, dass der Ort der Installation mindestens das Vierfache des Gesamtgewichts von Brüstungshalterung und Kamera aushalten kann.
- Bei der Montage dieses Produkts benötigt man Ankerbolzen und Muttern (M8).
- Jeder Ankerbolzen muss einer Ausziehungskraft von 700 kg standhalten können.
- Wenn das Produkt im Freien montiert wird, müssen Verriegelungseinrichtungen aus Edelstahl verwendet werden.

- Asegúrese de que el lugar de instalación pueda soportar al menos 4 veces el peso total del soporte para barandilla y de la cámara.
- Este producto se ha diseñado para utilizar tornillos de anclaje M8 (tuercas) para la instalación.
- Cada perno de anclaje debe tener la capacidad de soportar una fuerza de extracción de 700 kg.
- Al instalar el producto en exteriores, utilice dispositivos de interbloqueo de acero inoxidable.

- Assicurarsi che il luogo di installazione possa sopportare almeno 4 volte il peso totale della staffa per montaggio sulla balaustra e della telecamera.
- Questo prodotto è progettato per utilizzare bulloni di ancoraggio M8 (dadi) per l'installazione.
- Ogni bullone di ancoraggio deve poter resistere ad una forza di estrazione di 700 kg.
- Per installare il prodotto all'aperto, utilizzare dispositivi di ancoraggio in acciaio inossidabile.

- Убедитесь, что место установки может выдержать вес, не менее чем в 4 раза превышающий общий вес крепления для парапета и камеры.
- Для установки этого продукта необходимо использовать крепежные болты (гайки) M8.
- Необходимо, чтобы каждый крепежный болт мог выдержать силовую отдачу в 700 кг.
- Если продукт устанавливается вне помещения, необходимо использовать устройство блокировки из нержавеющей стали.

- Miejsce montażu powinno wytrzymać co najmniej 4 razy większe obciążenie niż całkowita waga uchwytu parapetowego i kamery.
- Produkt ten należy montować za pomocą kotew (nakrętek) M8.
- Każda kotwa musi mieć zdolność wytrzymania siły wyciągania 700 kg.

Installation

- 1 Peel off the 2 tapes fixing the Mounting Assembly.
- 2 Detach the Fixing bracket from of the Mount Plate.

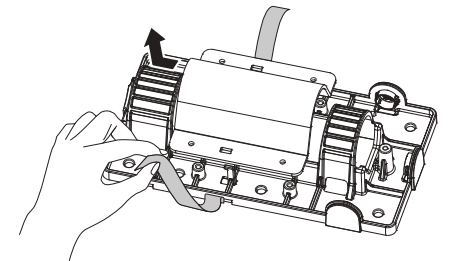

- 3 Install the mount plate on a wall using the hexagon socket head screw (8 pcs) included.

- When installing the product on a wall, mark and drill 8 holes into the Mount Plate and insert the Hexagon socket head screws before installation.
- Depending on some installation conditions, this product can be connected to 0.75" PF which is a screw peak processed pipe. There are three directions available for inserting the pipe.

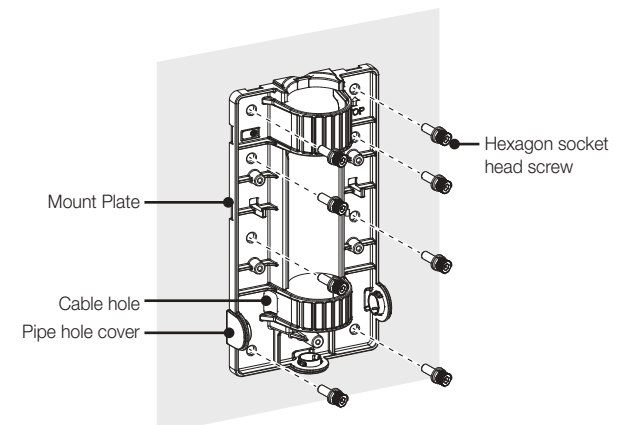

- 4** Insert the Arm Assembly in the Mount Plate and turn it toward the direction you want.

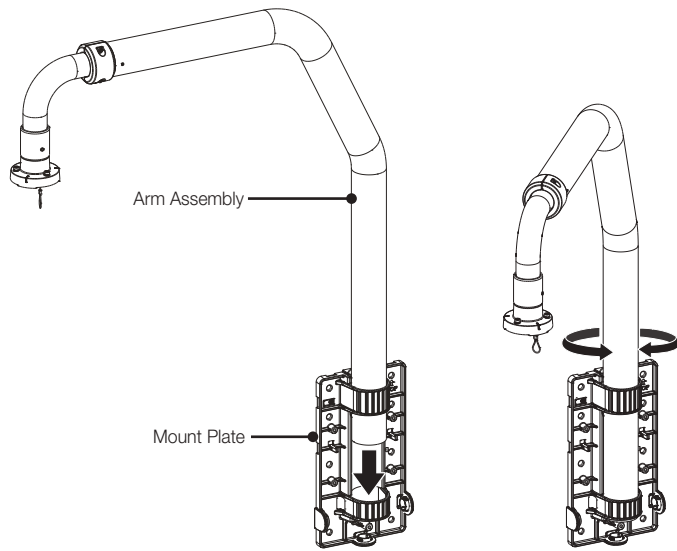

- 5** Using the given 4 Machine Screws, join the Fixing Bracket to the Mount Plate.

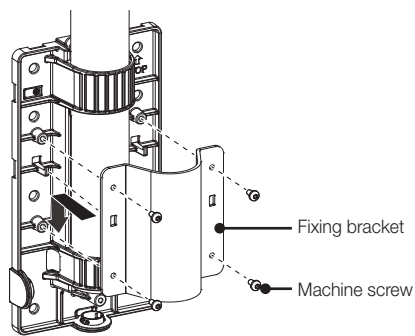

- 6** Loosen the 2 screws shown in the figure below to adjust the arm length of the Arm Assembly.

- After adjusting the length, tightly fasten the screw to secure it.

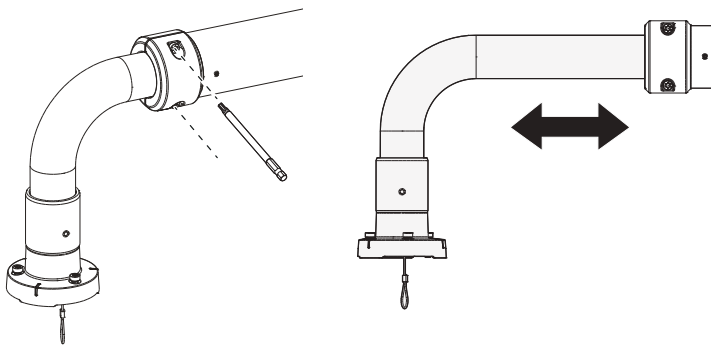

- 7** Take out the Rubber Holder from the inside of the bottom of the Arm Assembly.

- 8** After separating the Rubber Holder from the Cap Installer, plug the Network Cable in the Cap Installer.

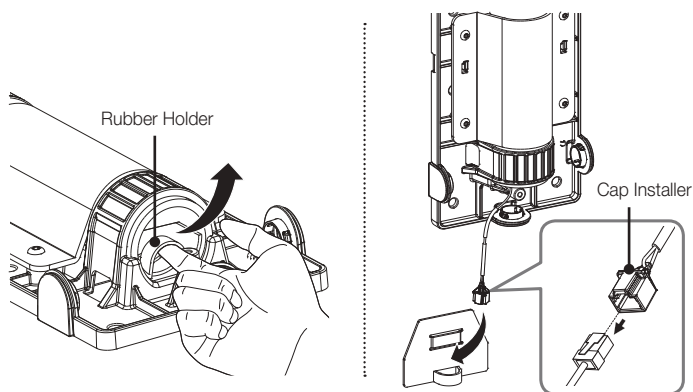

- 9** Peel off the tape that holds the cable to the top part of the Arm Assembly, and then pull the cable to drag the Network Cable.

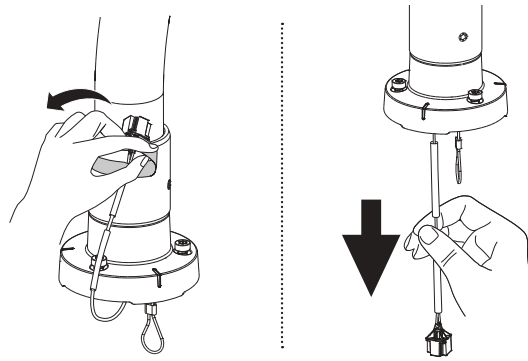

- 10** After aligning the installation direction guides of the camera and Parapet Mount, push the main cover upward and turn it counterclockwise until it is secured.

- Install the camera according to the camera's installation guide.

- 11** Tightly fasten the 3 mounting screws on the Parapet Mount.

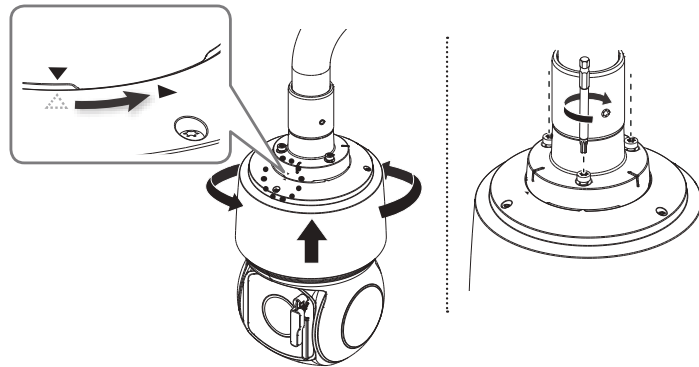

- 12** Using the Hex. L Wrench, loosen the screw shown in the figure below to adjust the direction of the camera.

- After adjusting the direction, tightly fasten the screw to secure it.

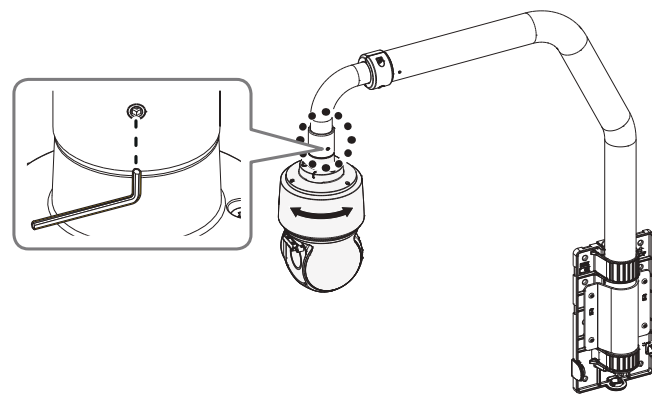

- 13** Join the cover of the Parapet mount using the screw bit included.

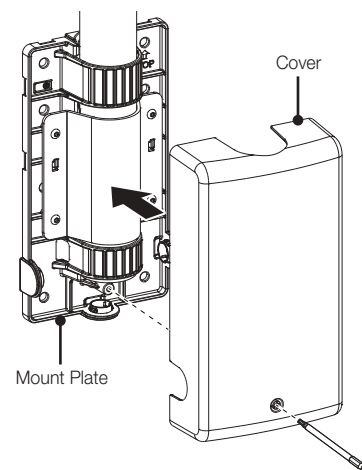

* The Parapet Mount contains a Hanging Mount. You can remove the Hanging Mount to use it separately, or you can install another mount or camera that has a screw thread of 1.5" PF to the Parapet Mount.

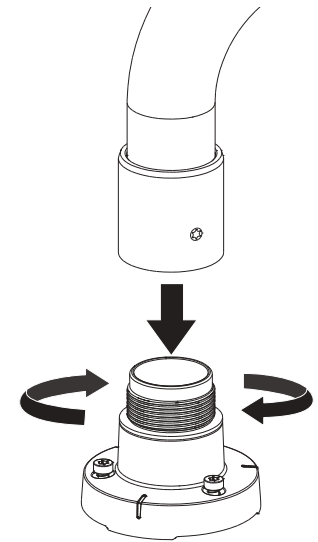

Product Specifications

Product Name	SBP-156LMW
Supported product	XNP-9300RW / XNP-8300RW / XNP-6400RW * models can be added without notice
Color / Material	White / Aluminum
RAL Code	RAL9003
Product dimensions (WxHxD) / weight	1,116(Max.) x 1,000 x 95 (43.9(Max.) x 39.4 x 3.8") / 7.1 kg (15.7 lb)

Product Overview

mm[inch]

