

SHB-V-3200HPR

Quick Guide

Outdoor Enclosure Kit
for Box Cameras



Outdoor Enclosure Kit for Box Cameras

Quick Guide

Copyright

©2023 Hanwha Vision Co., Ltd. All rights reserved.

Trademark

Each of trademarks herein is registered. The name of this product and other trademarks mentioned in this manual are the registered trademark of their respective company.

Restriction

Copyright of this document is reserved. Under no circumstances, this document shall be reproduced, distributed or changed, partially or wholly, without formal authorization.

Disclaimer

Hanwha Technin makes the best to verify the integrity and correctness of the contents in this document, but no formal guarantee shall be provided. Use of this document and the subsequent results shall be entirely on the user's own responsibility. Hanwha Technin reserves the right to change the contents of this document without prior notice.

❖ Design and specifications are subject to change without prior notice.

CONTENTS

OVERVIEW 4 What's Included





4

INSTALLATION & CONNECTION 5 Installation

5

WHAT'S INCLUDED

Please check if your camera and accessories are all included in the product package. Each item may be package in its' own box.

Appearance	Item Name	Quantity
	HOV32K2A700 OUTDOOR HOUSING WITH POE/HPOE	1
	WBJA WALL BRACKET WITH BALL JOINT	1
	IRH30L IR ILLUMINATOR	1
	OSUPPIR BRACKET FOR IR ILLUMINATOR	1

Note: A PoE/PoE+ switch or injector is required, not included.

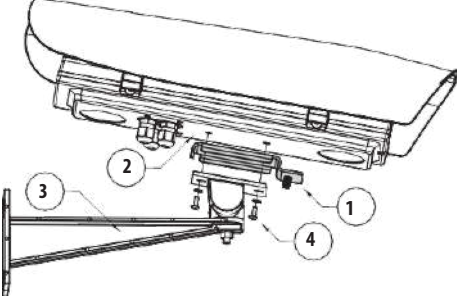
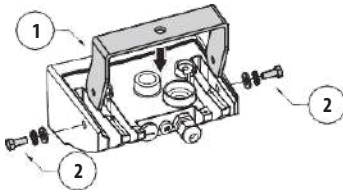
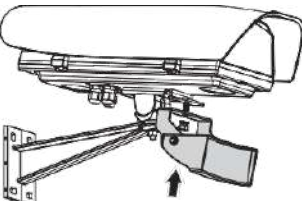
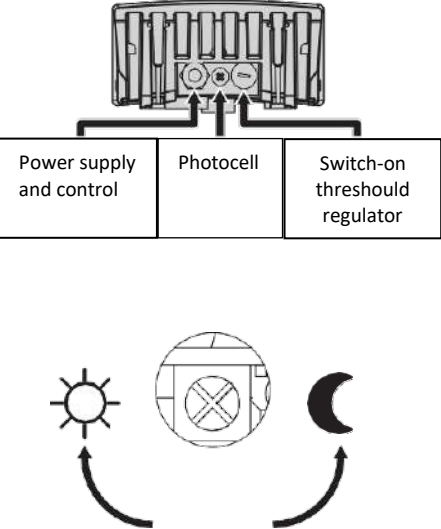
<p>Quick Installation of housing, wall mount, and illuminator:</p> <p>Fasten the plate (1) between the bottom of the housing (2) and the bracket (3) using the supplied screws (4).</p>	
<p>Fasten the top bracket (1) to the illuminator using the screws and washers (2) supplied.</p>	
<p>Fasten the illuminator and bracket using the nut and the washer.</p> <p>Set the vertical and horizontal angle, checking the resulting illumination range on the screen. Tighten all the screws.</p>	
<p>Twilight sensor activation threshold adjustment</p> <p>The illuminator has an integrated twilight sensor that allows its automatic activation and deactivation at predefined luminous conditions.</p> <p>The twilight sensor is set in the factory at a predetermined luminous level, suitable for most installations (approximately 50lx). If you want to adjust the threshold, loosen the plug on the illuminator rear and make adjustments with a screwdriver.</p> <p>By rotating the trimmer clockwise, the night mode changeover occurs at a greater luminous value. By rotating the trimmer counter-clockwise, the night mode changeover is delayed to a lower luminous value.</p> <p>Wait for appropriate brightness before switching on the illuminator. Rotate the trimmer slowly until the LED on the side of the trimmer switches on. Once the intervention threshold has been surpassed (LED on), rotate it slightly in the opposite direction.</p>	

Opening the housing

Loosen the 2 screws on the side of the housing, allowing the cover and the upper half of the body to pivot open on the hinge.

Slide removal

To remove the slide it is necessary to partially unscrew the fixing screws as shown in the figure.

Move the slide by sliding it until the holes coincide with the slide locking screws.

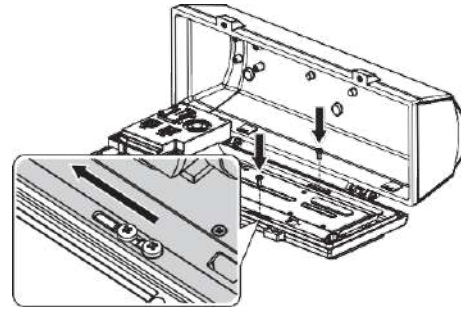

Installation of cable glands

Inside the supply are 3 cable glands that must be installed at the bottom of the housing as shown in the figure. The cable glands that are not used must be sealed with a cap to avoid water entering the housing.

1.1.1 Ethernet cable installation

Insert the Ethernet cable in the gasket and block it as shown in the figure.

Fit the gasket (1) to the cable gland M20 (2). Fasten the cable gland to the bottom of the housing (3) using the M20 nut.

 Pay attention to the fixing. Tightening torque: 7Nm.

Pass the cable with RJ45 connector (5) through the M20 cable gland (2). Tighten the cable gland cap (6).

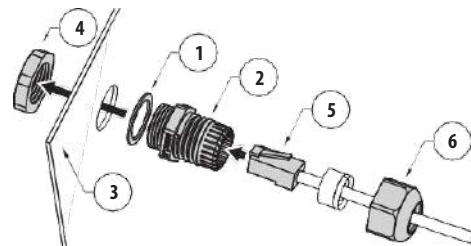
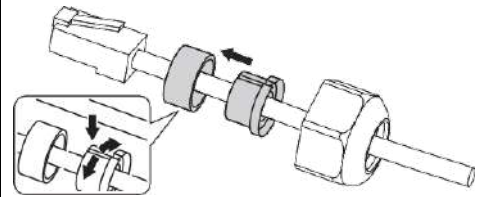

How to install the camera (not included)

The correct operation of the equipment, within the temperature range indicated, is guaranteed only if you use a camera and lens with temperature limits equal to at least -10°C and +60°C (14°F to 140°F)

Mount the camera (not included) using the supplied screws (1) and spacers (2).

Apply at least one spacer to guarantee electrical isolation between the slide and the camera.

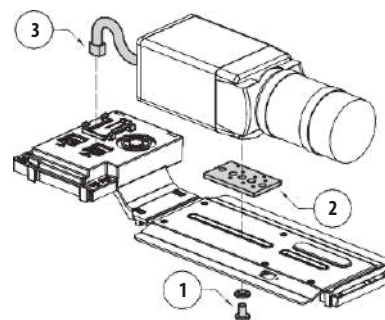

Position the camera lens (not included) close to the glass to avoid visual interference or optical reflections.
Connect the camera to the J2 connector (3) (PoE+ OUT)

Refit the slide in its housing and fix the previously loosened screws.

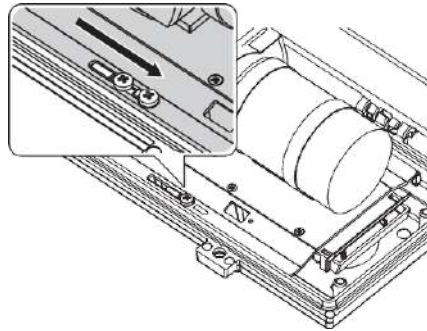

Connection of the illuminator

Connect the illuminator to the J6 terminal as described in the diagram below.

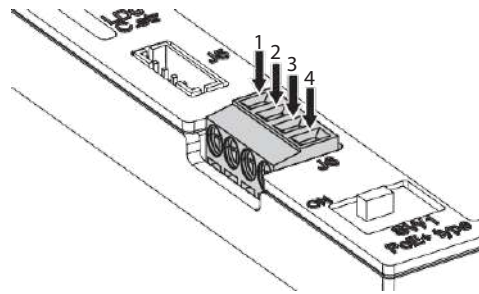

CONNECTION OF THE ILLUMINATOR

Illuminator	Terminal J6
Green (telemetry)	1
Red (telemetry)	2
White (power supply)	3
Black (power supply)	4

PoE+ cable connection

Connect the PoE+ cable from the Power Injector to the J1 connector.

Before powering the device, you must set the maximum power consumption of the housing operating on dip switch SW1, below.

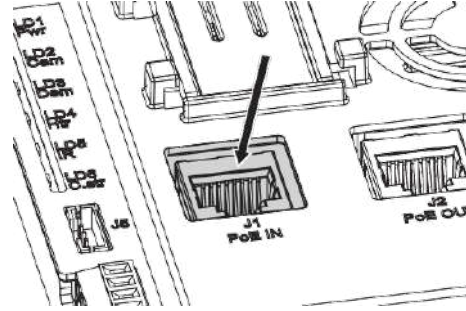

Configuration

Before powering the device, you must set the maximum power consumption of the housing to ON for PoE+ class 4 (25.5W maximum output) operating on dip switch SW1. PoE+ is required due to the use of the illuminator, defroster, & PoE+ camera.

POWER CONSUMPTION CONFIGURATION

SW1	Maximum power
ON	PoE+ Class 4 (25.5W max)

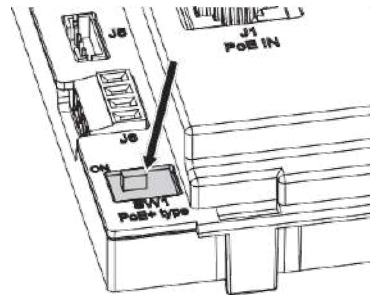

Switching on

i *The automatic pre-heating (De-Ice) process can start whenever the device is switched on and the ambient temperature is below 0°C (+32°F). The procedure is necessary to guarantee correct operation of the devices even at low temperatures.*

The duration ranges depending on environmental conditions (from 60 minutes up to 120 minutes).

During power on and boot up the device reads the status of the dip switch and automatically detects all of the connected options for the correct power management of the housing.

The LEDs shown in the figure allow you to check the product's operating status.

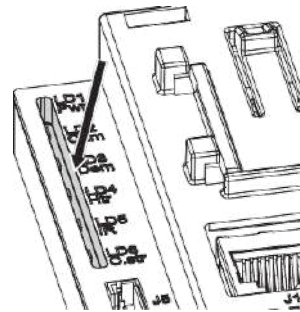

The LEDs shown in the figure allow you to check the product's operating status.

OPERATING STATUS		
LED	LED Status	Apparatus Status
LD1 (Power supply)	Off	The device is not powered
	On	The device is correctly powered
LD2 (Camera)	Off	The camera is not connected or Cold Start is active
	On	The camera is correctly powered
	1 flashing	The camera has a low identification resistance
	2 flashings	The camera has a high identification resistance
	5 flashings	The camera has an excessive power consumption
	9 flashings	The camera requires more power than the available
LD3 (Demisting)	Off	Demisting was not correctly detected
	1 flashing	Standard demisting is inactive
	2 flashings	The anti-ice system (optional) is inactive
	On	Demisting, or anti-ice system, is in operation
LD4 (Heater)	Off	Heating is not available or power available is not sufficient
	1 flashing	Heating is inactive
	On	Heating is active
LD5 (Illuminator)	Off	The illuminator (optional) is not detected or the available power is not sufficient
	1 flashing	The illuminator is correctly powered (illuminator activation is controlled by the photocell)
LD6 (Delayed activation)	Off	Heating is not available
	1 flashing	The pre-heating procedure is inactive
	On	The pre-heating procedure is underway

Procedure to assemble the camera with the lens. (Note: Camera and Lens are not included with the housing.)

Carefully insert the lens screw threads into the camera body and fully tighten. Attach the lens iris cable into the camera body connector. Adjust the lens zoom / focus levers. You may need to perform a Focus Initialization to adjust the sensor position after installation. Then perform a Simple Focus.

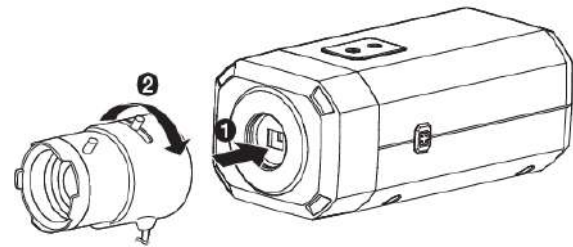

Please consult the camera user manual and Quick Guide for additional configuration steps that may be necessary, such as configuring a password and IP addressing.

Please note that camera and lens are to be purchased separately. Refer to mount selection tool for camera compatibility

Hanwha Vision America

500 Frank W. Burr Blvd. Suite 43 Teaneck, NJ 07666

Toll Free +1.877.213.1222 Direct +1.201.325.6920

Fax +1.201.373.0124

www.hanwhavisionamerica.com

