

ACTI CORPORATION

TEST REPORT

SCOPE OF WORK

IP66 OF IEC 60529:1989 + A1:1999 + A2:2013 DEGREES OF PROTECTION PROVIDED BY ENCLOSURES (IP CODE) – OUTDOOR SPEED DOME WITH D/N - [MODEL Z958]

REPORT NUMBER

240600093TPE-001

ISSUE DATE

26-June-2024

[REVISED DATE]

[none]

PAGES

15

DOCUMENT CONTROL NUMBER

GFT-OP-10h (03-Oct-2023)

© 2024 INTERTEK



TEST REPORT

Issued: 26-June-2024

Intertek Report No. 240600093TPE-001

Intertek Project No. TWJ24060215

Katy Chen, Ph: +886 2 2656 2588
Acti Corporation
7F., No. 1, Alley 20, Lane 407, Sec. 2, Tiding Blvd., Neihu District, Taipei 114, Taiwan, R.O.C.
email: katy.Chen@acti.com

Subject: IP66 of IEC 60529:1989 + A1:1999 + A2:2013 Degrees of protection provided by enclosures (IP Code) of the Outdoor Speed Dome with D/N, model Z958.

Dear Ms. Katy Chen,

This test report for Outdoor Speed Dome with D/N, model Z958 represent the result of our evaluation of the above referenced product(s) to the requirements contained in the following standards:

METHODS PER ISO/IEC 17025:2017 7.8.2.1f

DESCRIPTION OF TEST METHODS AND STANDARDS

IP6x Test (sub-clauses 12.2, 12.3, 13.4 and 13.6 of IEC 60529)

IPx6 Test (sub-clauses 14.2.6 and 14.3)

SAMPLES PROVIDED PER ISO/IEC 17025:2017 7.8.2.1h & i

SAMPLE #	SAMPLE RECEIVED	SERIEL #	DATE	CONDITION
P240600065	Z958	S240600233	2024/06/12	IP66

TESTED <13-June-2024 to 20-June-2024>

This report is for the exclusive use of Intertek's Client and is provided pursuant to the agreement between Intertek and its Client. Intertek's responsibility and liability are limited to the terms and conditions of the agreement. Intertek assumes no liability to any party, other than to the Client in accordance with the agreement, for any loss, expense or damage occasioned by the use of this report. Only the Client is authorized to permit copying or distribution of this report and then only in its entirety. Any use of the Intertek name or one of its marks for the sale or advertisement of the tested material, product or service must first be approved in writing by Intertek. The observations and test results in this report are relevant only to the sample tested. This report by itself does not imply that the material, product, or service is or has ever been under an Intertek certification program.

TEST REPORT**SCOPE OF RESULTS PER ISO/IEC 17025:2017 7.8.2.1l**

The observations and test results in this report are relevant only to the sample tested. This report by itself does not imply that the material, product, or service is or has ever been under an Intertek certification program.

ADDITIONAL TEST METHOD INFORMATION PER ISO/IEC 17025:2017 7.8.3.1a & 7.8.2.1n

There were no deviations from the test methods.

RESULTS PER ISO/IEC 17025:2017 7.8.2.1m

Compliant with the Requirement, refer to appendix for details.

MEASUREMENT UNCERTAINTY PER ISO/IEC 17025:2017 7.8.3.1c

Per ISO 17025 7.6.3, NOTE 1 a well-recognized test method was used that specifies the limits on major sources of uncertainty and controls the presentation and calculation of results.

REPORTING STATEMENTS OF CONFORMITY REQUIRED PER ISO/IEC 17025:2017 7.8.6

Please note that the test results with statement of conformity, the decision rules which are based on:
Safety Testing: the specification, standard or IEC Guide 115.
Other Testing: the specification, standard and not taking into account the measurement uncertainty.

REPORT AUTHORIZED PER ISO/IEC 17025:2017 7.8.2.1o

When signed with physical or electronic signature, the contents of this report have been prepared and approved per Intertek's quality process in accordance with ISO 17025.



Engineer



Reviewer

TEST REPORT

REPORT REVISIONS

Date/ Proj#	Project Handler/ Reviewer	Description of Change
2024-06-26 / TWJ24060215	Kelen Chen / Anton Chen	Original

TEST REPORT

IP6X Test (sub-clause 12.2 and 12.3 of IEC 60529):

Test Method:

Access probe below to test the protection of persons against access to hazardous parts.

First numeral	Addit. letter	Access probe	Test force
4, 5, 6	D	<p>Test wire 1,0 mm diameter, 100 mm long</p> <p>Approx. 100</p> <p>Sphere $35 \pm 0,2$</p> <p>$100 \pm 0,2$</p> <p>$\varnothing 10$</p> <p>Handle (Insulating material)</p> <p>Stop face (Insulating material)</p> <p>Rigid test wire (Metal)</p> <p>Edges free from burrs</p> <p>$\varnothing 1,0 \pm 0,05$</p> <p>IEC 276/01</p>	1 N ± 10 %

Compliance criteria:

The protection is satisfactory if adequate clearance is kept between the access probe and hazardous parts.

The access probe shall not touch hazardous live parts.

If adequate clearance is verified by a signal circuit between the probe and hazardous parts, the lamp shall not light.

Test Result:

12.3	IP6x Test	Pass
Result		
The access probe did not touch hazardous live parts.		

TEST REPORT

IP6X Test (sub-clause 13.4 and 13.6 of IEC 60529):

Test Method:

The test is made using a dust chamber incorporating the basic principles shown in figure 2 whereby the powder circulation pump may be replaced by other means suitable to maintain the talcum powder in suspension in a closed test chamber. The talcum powder used shall be able to pass through a square-meshed sieve the nominal wire diameter of which is 50 μm and the nominal width of a gap between wires 75 μm . The amount of talcum powder to be used is 2 kg per cubic metre of the test chamber volume. It shall not have been used for more than 20 tests.

NOTE Health and safety regulations should be observed in selecting the type of talcum powder and its use.

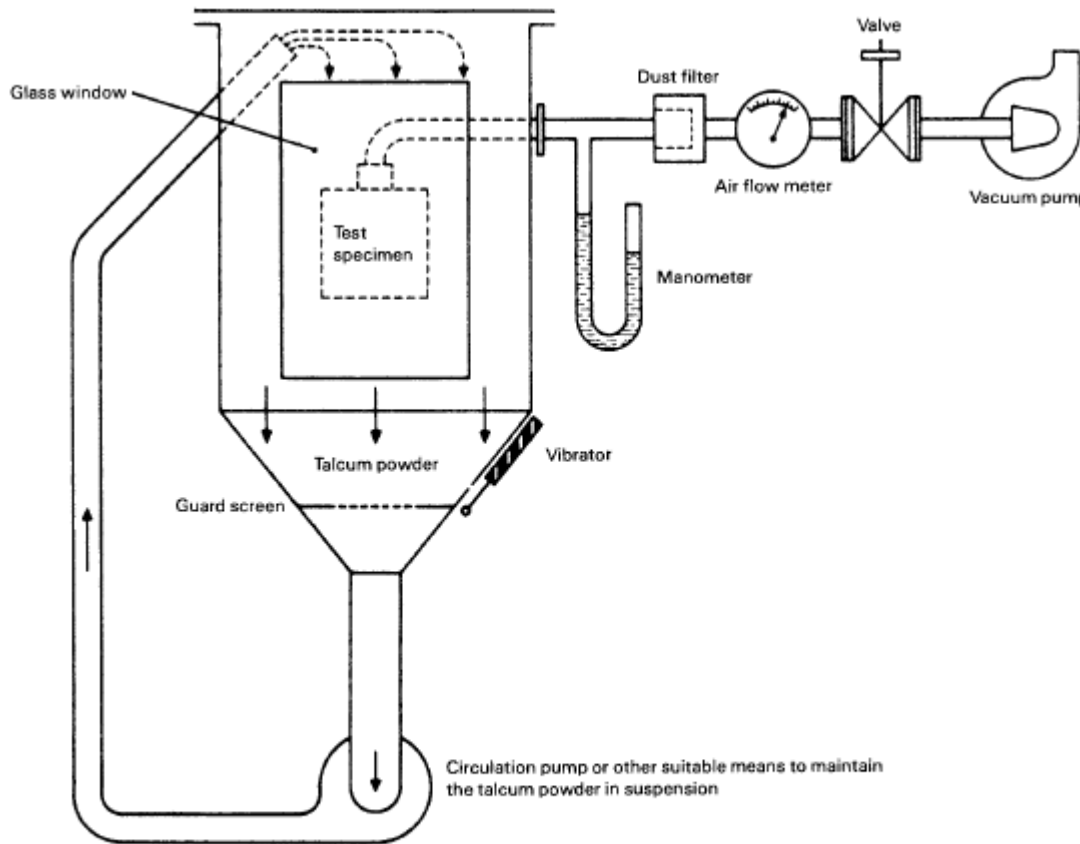

IEC 280/01

NOTE See IEC 60068-2-68, figure 2 valid for La2 only.

Figure 2 – Test device to verify protection against dust (dust chamber)

TEST REPORT

IP6X Test (sub-clause 13.4 and 13.6 of IEC 60529) (cont'):

Enclosures are of necessity in category 1:

Category 1: Enclosures where the normal working cycle of the equipment causes reductions in air pressure within the enclosure below that of the surrounding air, for example, due to thermal cycling effects.

Category 1 enclosures:

The enclosure under test is supported inside the test chamber and the pressure inside the enclosure is maintained below the surrounding atmospheric pressure by a vacuum pump. The suction connection shall be made to a hole specially provided for this test. If not otherwise specified in the relevant product standard, this hole shall be in the vicinity of the vulnerable parts.

If it is impracticable to make a special hole, the suction connection shall be made to the cable inlet hole. If there are other holes (for example, more cable inlet holes or drain-holes) these shall be treated as intended for normal use on site.

The object of the test is to draw into the enclosure, by means of depression, a volume of air 80 times the volume of the sample enclosure tested without exceeding the extraction rate of 60 volumes per hour. In no event shall the depression exceed 2 kPa (20 mbar) on the manometer shown in figure 2.

If an extraction rate of 40 to 60 volumes per hour is obtained the duration of the test is 2 h.

If, with a maximum depression of 2 kPa (20 mbar), the extraction rate is less than 40 volumes per hour, the test is continued until 80 volumes have been drawn through, or a period of 8 h has elapsed.

If it is impracticable to test the complete enclosure in the test chamber, one of the following procedures shall be applied:

- testing of individually enclosed sections of the enclosure;
- testing of representative parts of the enclosure, comprising components such as doors, ventilation openings, joints, shaft seals, etc., in position during test;
- testing of a smaller enclosure having the same full-scale design details.

In the last two cases, the volume of air to be drawn through the enclosure under test shall be the same as for the whole enclosure in full scale.

Compliance criteria:

The protection is satisfactory if no deposit of dust is observable inside the enclosure at the end of the test.

TEST REPORT

IP6X Test (sub-clause 13.4 and 13.6 of IEC 60529) (cont'):

Test Result:

13.4, 13.6	IP6x Test	Pass
Result		
No deposit of dust is observable inside the enclosure at the end of the test.		

TEST REPORT

IPX6 Test (sub-clause 14.2.6 and 14.3 of IEC 60529):

Test Method:

1. 14.2.6 Test for second characteristic numeral 6 with the 12,5 mm nozzle
2. The test is made by spraying the enclosure from all practicable directions with a stream of water from a standard test nozzle as shown in figure 6.
3. The conditions to be observed are as follows:
 - internal diameter of the nozzle: 12,5 mm;
 - delivery rate: 100 l/min \pm 5 %;
 - water pressure: to be adjusted to achieve the specified delivery rate;
 - core of the substantial stream: circle of approximately 120 mm diameter at 2,5 m distance from nozzle;
 - test duration per square metre of enclosure surface area likely to be sprayed: 1 min;
 - minimum test duration: 3 min;
 - distance from nozzle to enclosure surface: between 2,5 m and 3 m.

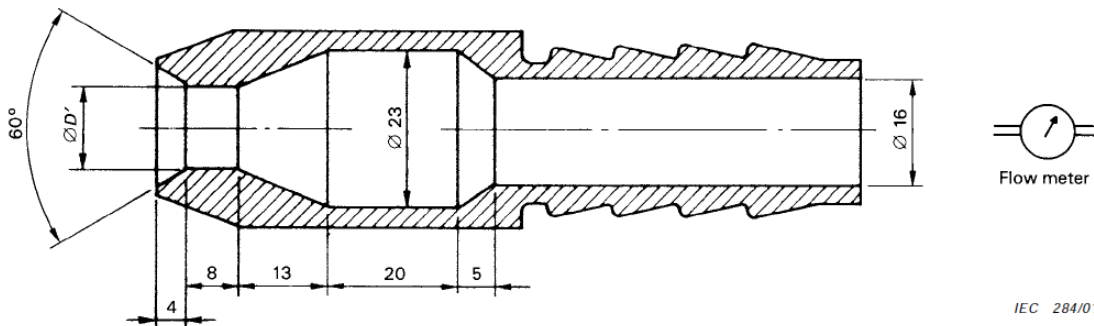

Dimensions in millimetres

$D' = 6,3$ for the test of 14.2.5 (second characteristic numeral 5)

$D' = 12,5$ for the test of 14.2.6 (second characteristic numeral 6)

Figure 6 – Test device to verify protection against water jets (hose nozzle)

TEST REPORT

IPX6 Test (sub-clause 14.2.6 and 14.3 of IEC 60529) (cont'):

Compliance criteria:

After the test, the enclosure shall be inspected for ingress of water.

In general, if any water has entered, it shall not:

- be sufficient to interfere with the correct operation of the equipment or impair safety;
- deposit on insulation parts where it could lead to tracking along the creepage distances;
- reach live parts or windings not designed to operate when wet;
- accumulate near the cable end or enter the cable if any.

If the enclosure is provided with drain-holes, it should be proved by inspection that any water which enters does not accumulate and that it drains away without doing any harm to the equipment.

For enclosures without drain-holes, the relevant product standard shall specify the acceptance conditions if water can accumulate to reach live parts.

Test Result:

14.2.5, 14.3	IPx6 Test	Pass
Result		
After the test, the inside of the EUT did not have water entered.		

TEST REPORT

APPENDIX1:

Photo of EUT before water test



TEST REPORT

Photo of EUT during water test

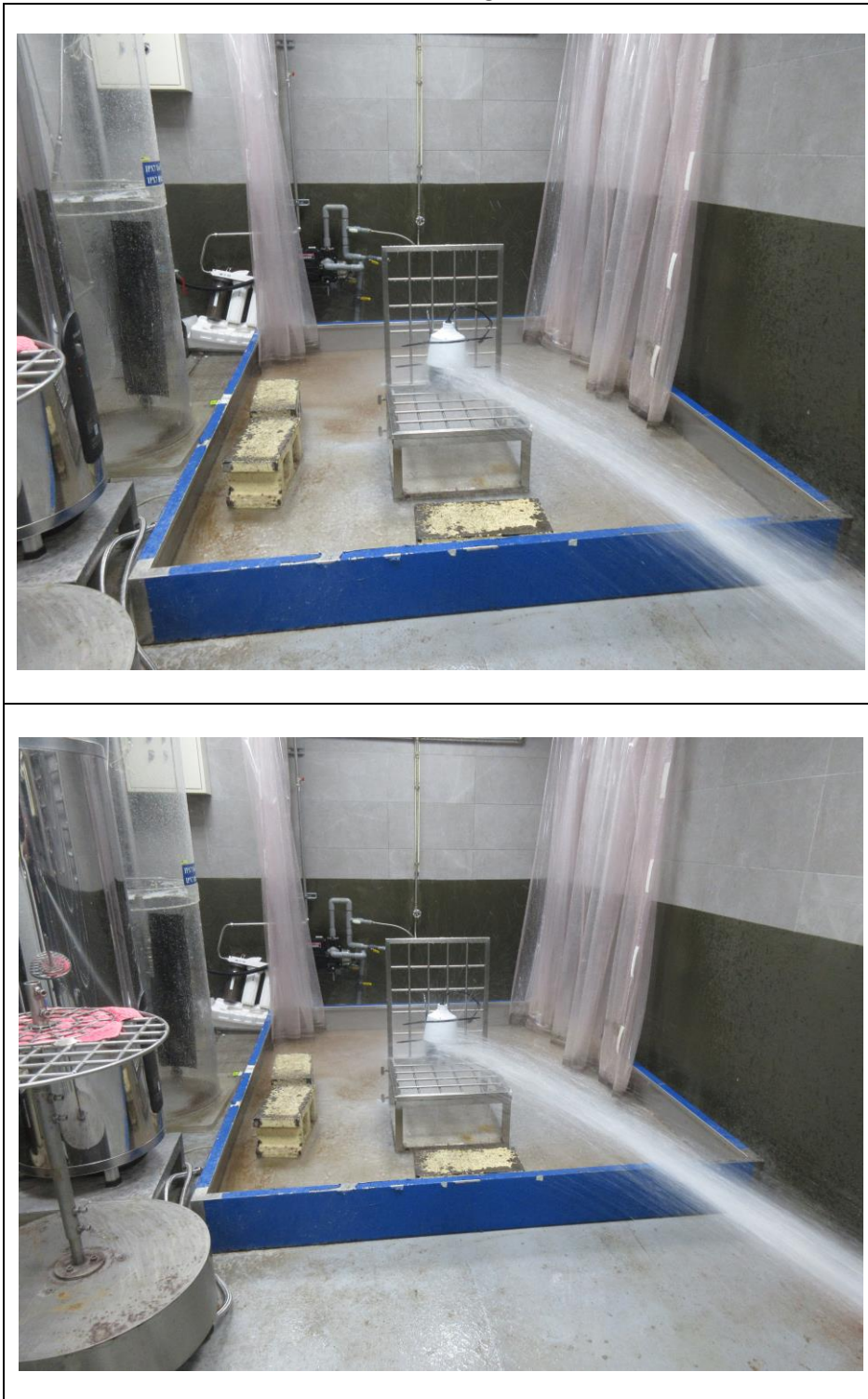

TEST REPORT

Photo of EUT after water test

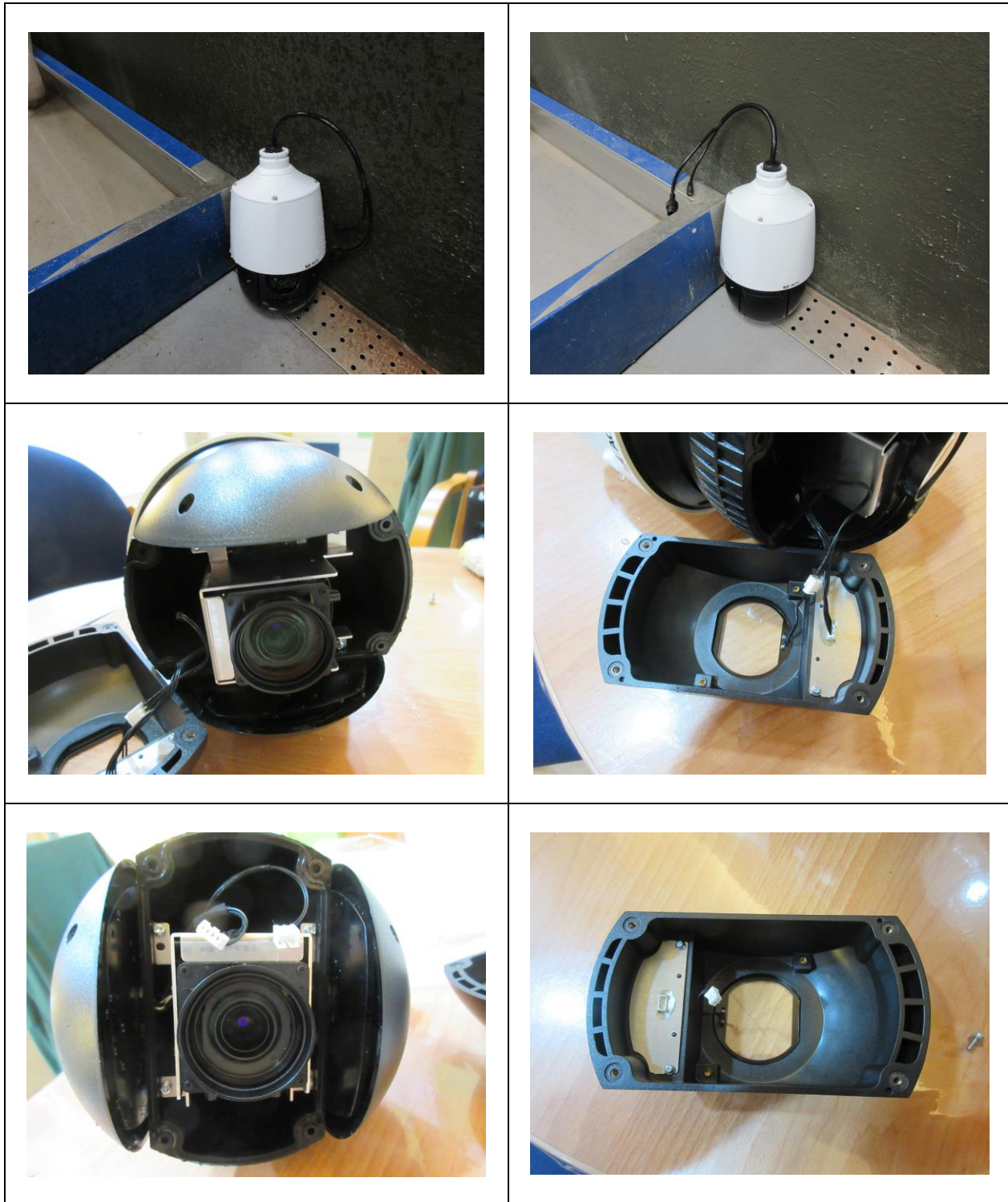

TEST REPORT

Photo of EUT during dust test

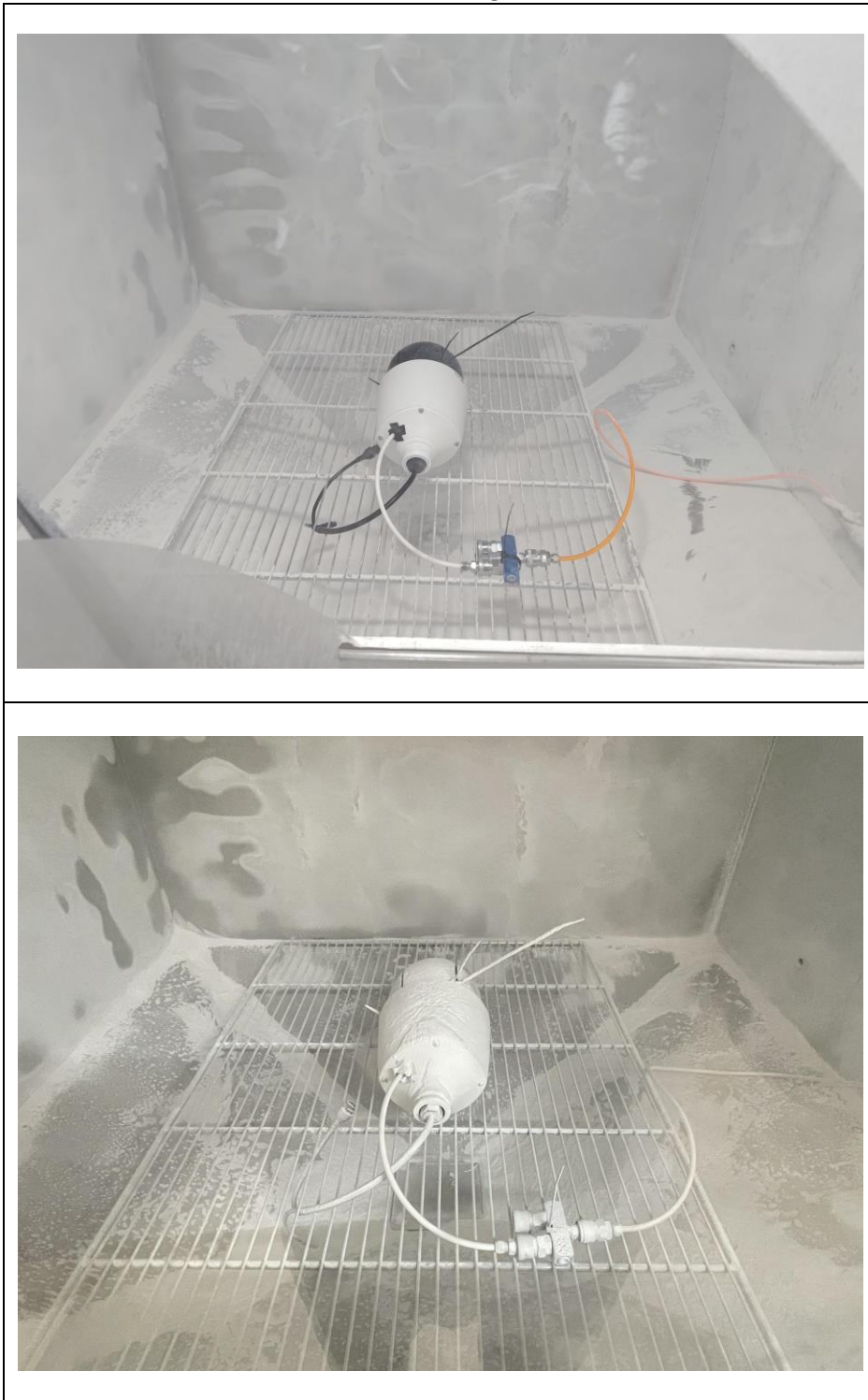

TEST REPORT

Photo of EUT after dust test

