

CaMate Series User's Manual

2017/11/17 Rev0.1

1. Introduction.....	4
1.1 Configuration & Control	4
2. Windows Application Software	6
2.1 Configuration/Status Page	9
2.1.1 Apply change	9
2.1.2 Update	9
2.1.3 Device Info	9
2.1.4 LED Status	9
2.1.5 Device ID	9
2.2 Baudrate	11
2.3 LED Control Mode.....	11
2.3.1 DI mode	11
2.3.2 Direct mode	12
2.3.3 Timer mode	13
2.3.4 Light sensor mode	13
2.4 Fade in/out.....	13
2.5 Trigger Level	14
2.6 LED indicator.....	15
2.7 Ambient Light.....	15
2.8 LED Light Level	15
2.9 DO Mode	15
2.9.1 DO light sensor mode	15
2.9.2 DO LED state mode.....	15
2.9.3 DO Diagnostic mode	15
2.10 Angle Level (Only available for the motorized version of CaMate, e.g. CA48I8-1040)	16
2.11 Diagnostic Page.....	16
2.11.1 System power on time (hours)	17
2.11.2 LED power on time (hours).....	17
2.11.3 Inputs	17

2.11.4 LED Voltage.....	17
2.11.5 LED Temperature.....	17
2.11.6 MCU Temperature.....	17
2.11.7 Boot count	17
2.11.8 Error code	17
2.12 Firmware Upgrade.....	18
2.13 FactoryCode Page.....	21
3. Android APP.....	22
4. Remote Controller	25
5. Appendix.....	28
5.1 Appendix A: Pelco-D set of CaMate.....	28
5.1.0 Use Windows Application Software to get commands	28
5.1.1 Soft reset (0x0F).....	30
5.1.2 Reset to default (0x29)	30
5.1.3 Set zoom position (0x4F)	30
5.1.4 Get zoom position (0x55)	30
5.1.5 Set Baud rate (0x67)	31
5.1.7 Set/Read Configuration information (0x6D)	31
5.1.7.1 LED control mode	32
5.1.7.2 Fade in/out control.....	32
5.1.7.3 DI/DO active polarity	33
5.1.7.4 DO mode.....	33
5.1.7.5 LED on/off.....	34
5.1.7.6 Indicator on/off	35
5.1.7.7 Device ID address	36
5.1.7.8 Clock time	36
5.1.7.9 Timer LED on.....	37
5.1.7.10 Timer LED off	37
5.1.7.11 DI/DO status	38
5.1.7.12 Hysteresis/Oversample of light sensor trigger	38
5.1.8 Query Diagnostic information (0x6F)	39
5.1.8.1 Temperature of LED/MCU	39
5.1.8.2 Measurement of Input voltage.....	40
5.1.8.3 Total System power on time.....	40
5.1.8.4 Total LED power on time	41
5.1.8.5 Current ambient light	41

5.1.8.6 Boot count	41
5.1.4.8.7 LED voltage	42
5.1.8.8 System error code	43
5.1.8.9 Count of over-heat and input voltage out of range	44
5.1.9 Query Version information (0x73).....	45
5.1.9.1 Firmware revision	45
5.1.9.2 Boot loader revision	45
5.1.9.3 Hardware revision	46
5.1.9.4 Serial number	46
5.1.9.5 Model ID	47
5.1.9.6 Maximum/Default LED current	47
5.1.9.7 Lens angle information	47
5.1.9.8 Factory date	47
5.1.9.9 Factory time.....	48
5.1.10 Set brightness level (0x7D)	48
5.1.11 Set ambient threshold level (0x7F).....	48
5.1.12 Get brightness level (0x81).....	49
5.1.13 Get ambient threshold (0x83)	49
5.2 Appendix B: Command set of CaMate.....	50

1. Introduction

The CaMate illuminators' variable beam angles can be adjusted via an RS485 connection. Using a USB-to-RS485 converter, the LED ON/OFF, trigger level, Dimming, Fade in/out can be remotely controlled.

1.1 Configuration & Control

CaMate can be configured and controlled through the RS485 interface and/or a remote controller. A PC or Android mobile phone can be used to configure CaMate through the RS485 interface. You can download a Windows application software and Android APP from "[www.vivotek.com\CaMate\app](http://www.vivotek.com/CaMate/app)." Devices that come with the RS485 interface, e.g. camera, can configure and control CaMate through the RS485 interface with a correct command set (refer to [Appendix A for Pelco-D](#) or [Appendix B for CaMate's commands](#)).

To connect a PC or Android device to a CaMate illuminator via the RS485 interface, an USB-to-RS485 converter should be used. The converter is separately purchased. An example is shown below:



An exemplary connection should look like this:

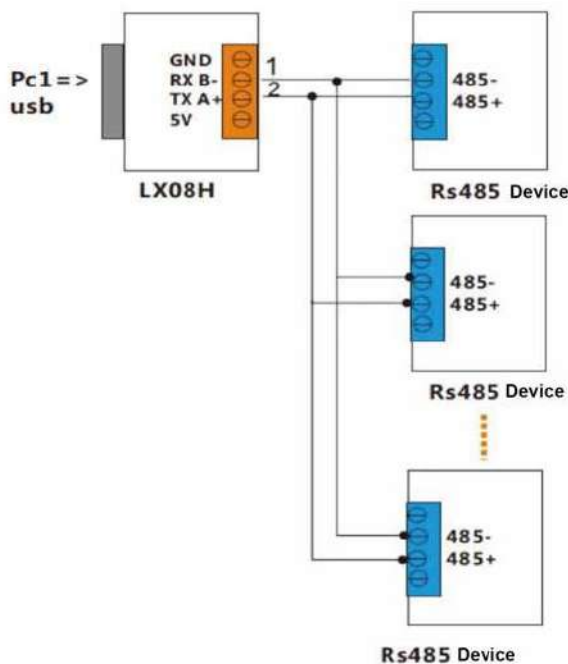

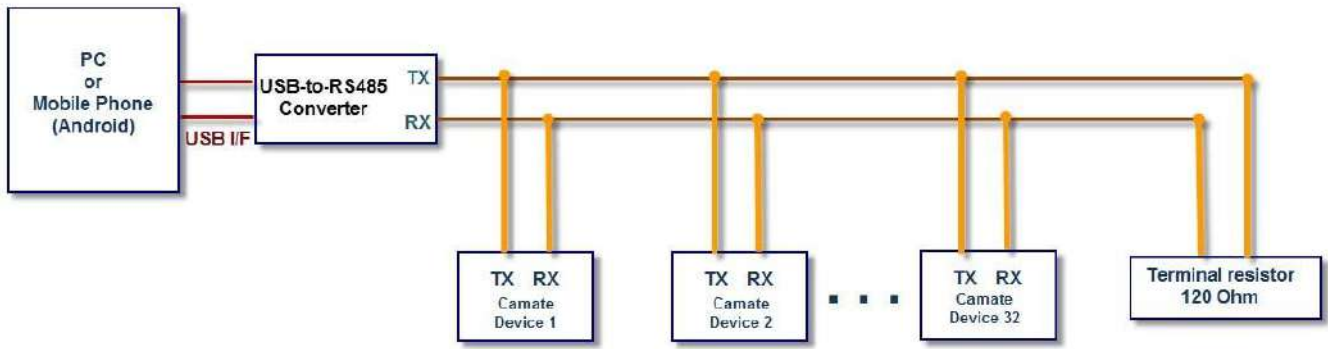

NOTES: If termination is required, a resistor value of 120Ω or greater should be used, and no more than 2 termination resistors should be used, one at each end of the RS485 transmission line.

2. Windows Application Software

After the device driver for the USB-to-RS485 converter is installed (refer to the installation guide that comes with the USB-to-RS485 converter), execute the **EXIR_ConfigurationTool.exe** application software.

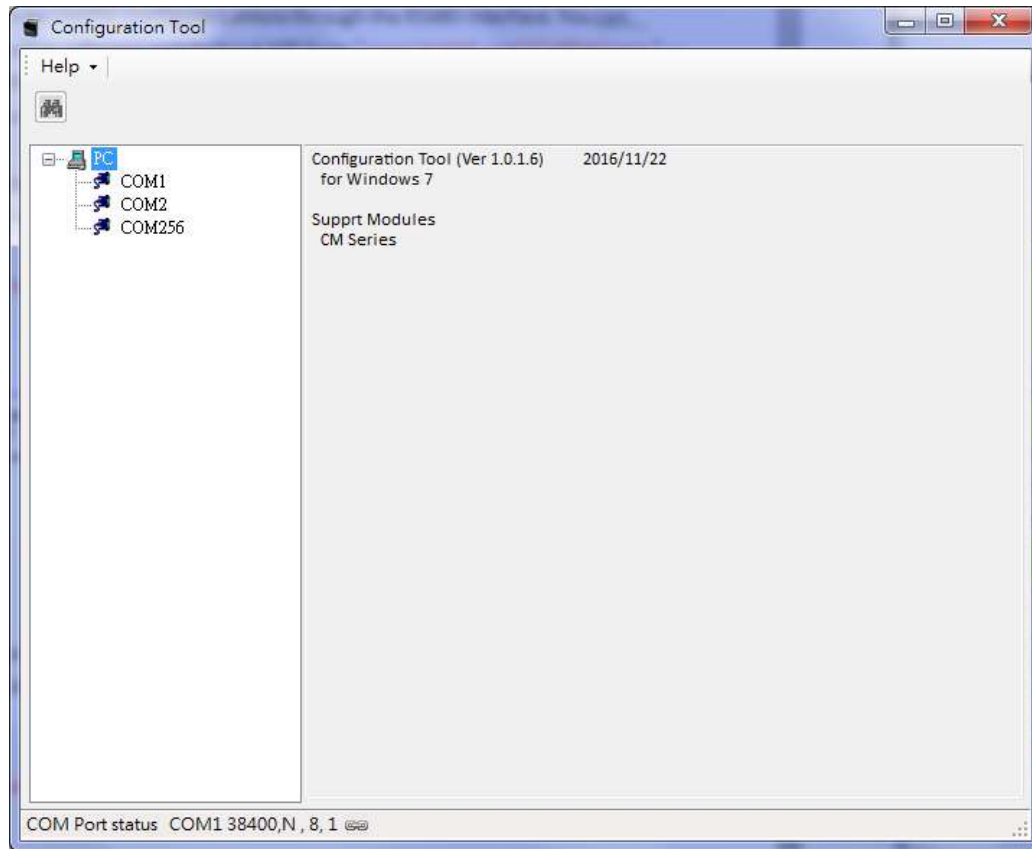

1. First select the correct COM port that is connected to CaMate.

If you are not sure of the baudrate of CaMate, (default is 38,400), you can use the Baudrate probe icon to search for the correct baudrate.

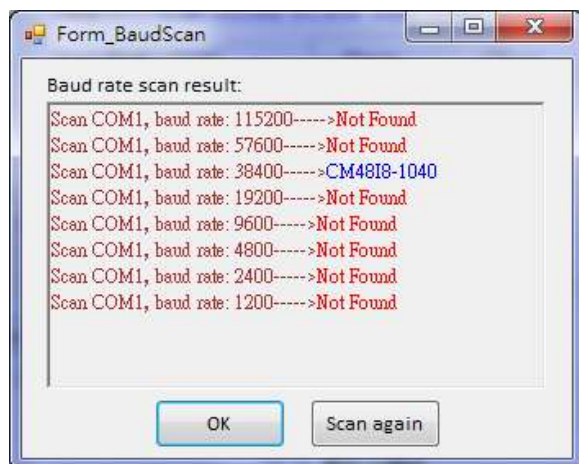

2. Then, configure the correct baudrate and click the Find icon. A search device window will prompt to ask for a start Device ID number. Default is 1. Unless a change to the device ID of your CaMate was made, otherwise, press OK to start finding from device ID 1. You can press the Stop scan button any time once your CaMate is found.

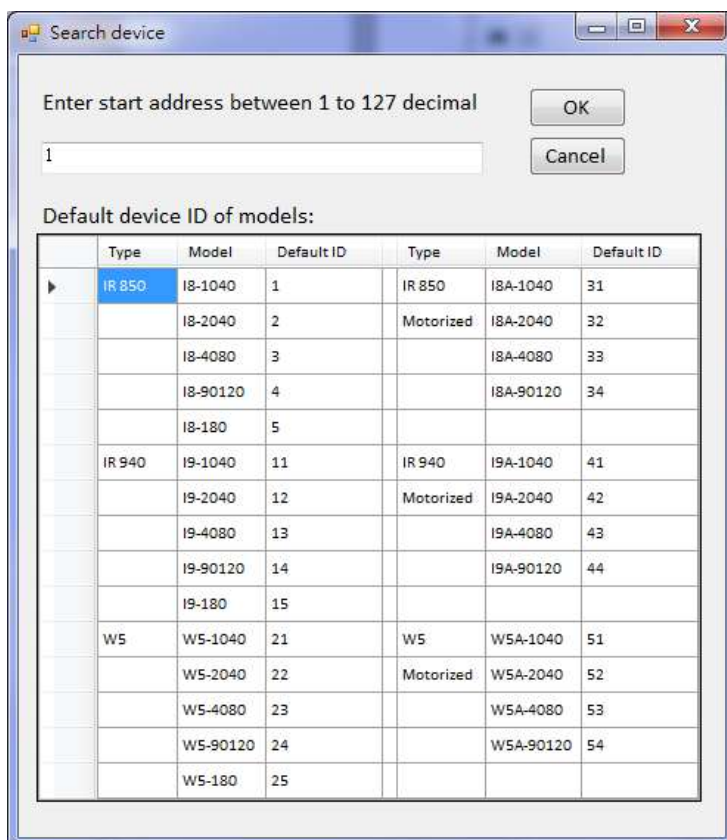
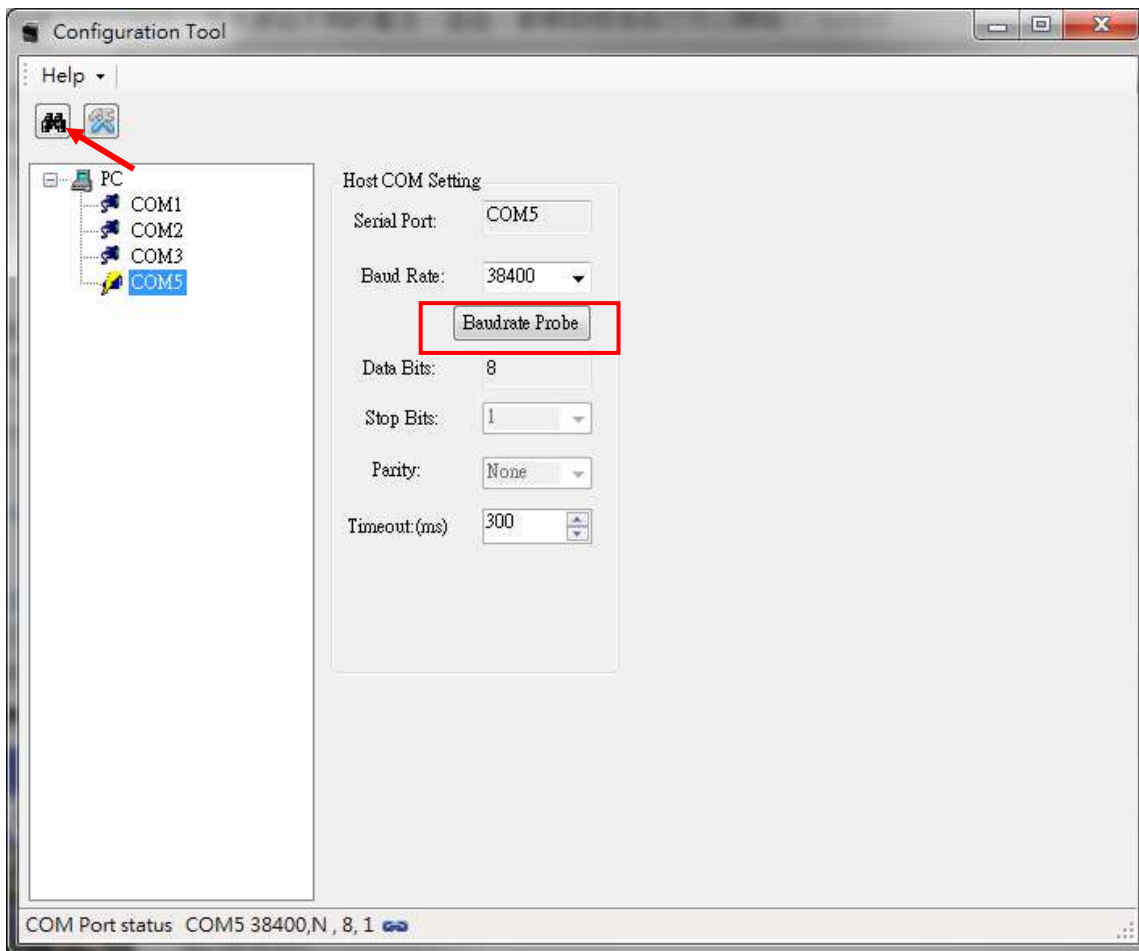

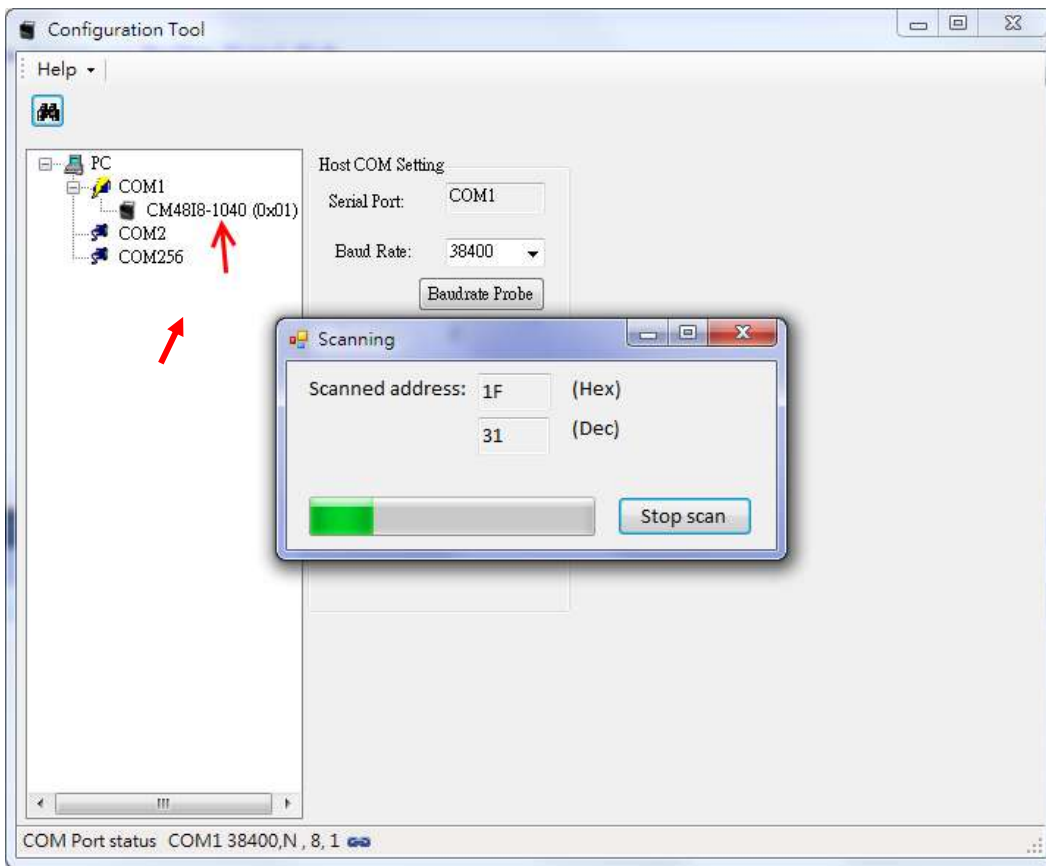

The CaMate illuminator thus found will be listed under the selected COM port. Select the CaMate you want to configure and/or control, and the Configuration/Status page will display.

2.1 Configuration/Status Page

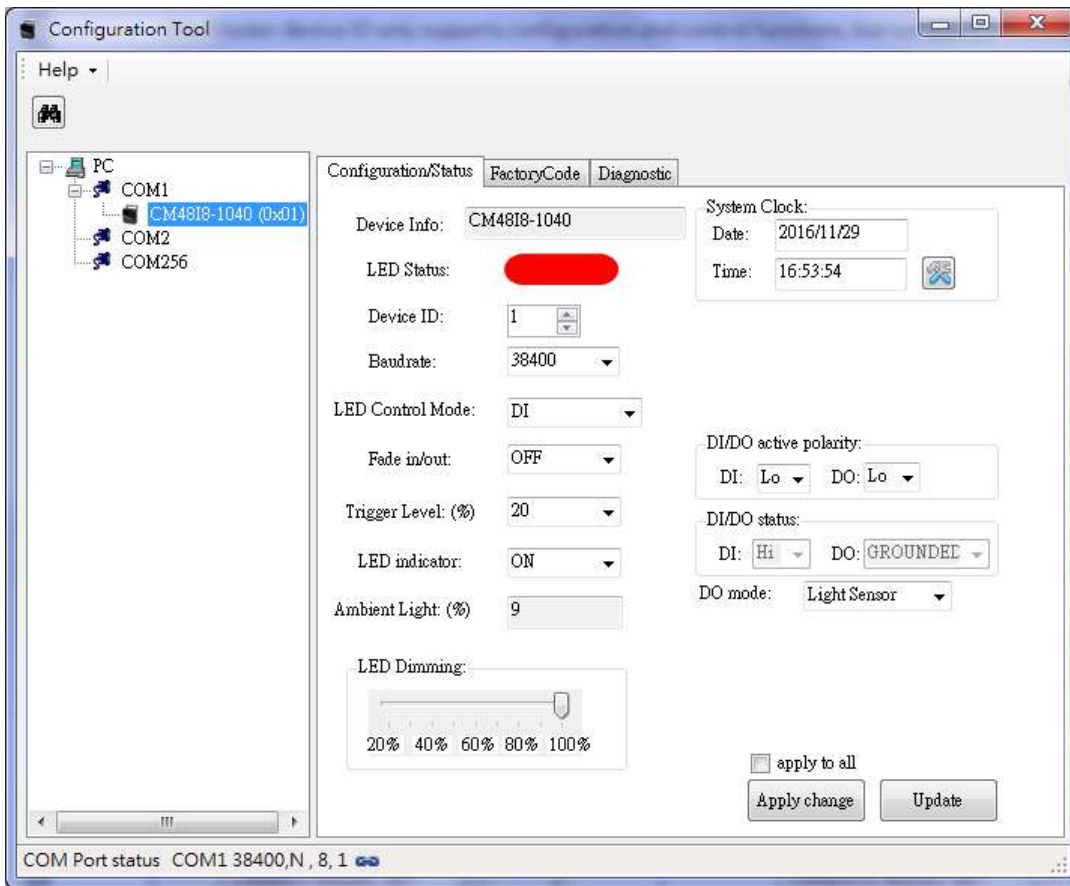

2.1.1 Apply change

The Apply change button lets the configuration values take effect. CaMate configuration values will not be saved until you click the Apply change button.

2.1.2 Update

The Update button is used to query the CaMate configuration to display on the software. To ensure the software is displaying the latest information from CaMate, you should use the Update button before you start to configure.

2.1.3 Device Info

Device Info indicates the CaMate model name, e.g., CM4818-1040.

2.1.4 LED Status

LED Status depicts the current ON/OFF state of LED. Red means OFF, and Green means ON.

2.1.5 Device ID

Each device comes with a unique Device ID when multiple CaMate devices are present on the RS485 bus. The Device ID ranges from 0 to 127. Make sure you configure different IDs for CaMate devices bearing the same model name. There are a total of 128 device IDs, i.e. 0 ~ 127. A special Master

Device ID 80h (128) can be used to configure any device no matter what the device ID of devices is (the Master device ID only supports configuration and control functions, but not query). The Master Device ID can be used to configure multiple devices connected together with the same configuration profile. If the apply to all checkbox is selected, the software will use the Master device ID to proceed with configuration.

The image shows a user interface element with a checkbox labeled "apply to all" that is currently unchecked. Below the checkbox are two buttons: "Apply change" and "Update".

Default Device ID of models

Model	Device ID	Remarks	
IR 850	CM48I8-1040	1	
	CM80I8-1040	1	
	CM48I8-2040	2	
	CM80I8-2040	2	
	CM48I8-4080	3	
	CM80I8-4080	3	
	CM48I8-90120	4	
	CM80I8-90120	4	
	CM48I8-180	5	
IR 940	CM48I9-1040	11	
	CM48I9-2040	12	
	CM48I9-4080	13	
	CM48I9-90120	14	
W5	CM48W5-1040	21	
	CM48W5-2040	22	
	CM48W5-4080	23	
	CM48W5-90120	24	

Model	Device ID	Remarks	
IR 850 motorized	CA48I8-1040	31	
	CA80I8-1040	31	
	CA48I8-2040	32	
	CA80I8-2040	32	
	CA48I8-4080	33	
	CA80I8-4080	33	
	CA48I8-90120	34	
	CA80I8-90120	34	
IR 940 motorized	CA48I9-1040	41	
	CA48I9-2040	42	
	CA48I9-4080	43	
	CA48I9-90120	44	
W5 motorized	CA48W5-1040	51	
	CA48W5-2040	52	
	CA48W5-4080	53	
	CA48W5-90120	54	

2.2 Baudrate

Baudrate sets the communication speed of CaMate devices on the RS485 interface. The Max. rate is 115,200, and the min. is 1,200. The default baudrate is 38,400. Remember to change the baudrate of application software immediately after you change the baudrate of a CaMate device. Mismatched Baudrate setting between a PC and CaMate devices will fail the RS485 communications. In some computers, the max. baudrate may only reach 38,400.

It is recommended not to change the baudrate of CaMate devices because once the baudrate is changed and forgotten, the only way is to run the PC software is to probe the baudrate.

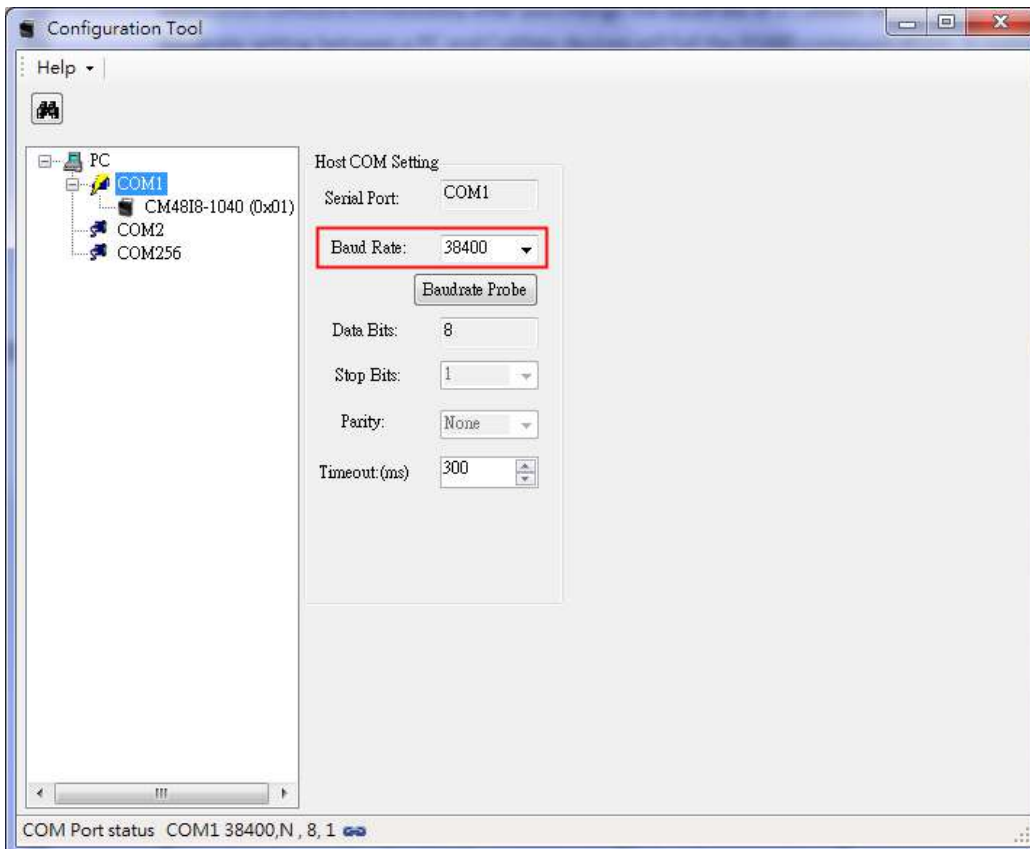

2.3 LED Control Mode

There are 4 control modes for the illuminator LEDs: DI mode, Direct mode, Timer mode, and Light sensor mode.

2.3.1 DI mode

In the DI mode, the system default, the LED ON/OFF is controlled via a DI signal. The associated configuration is DI/DO active polarity, which defines the activation polarity of DI, e.g. low voltage or high voltage. The DI/DO status shows the current state of DI and DO signal. The DI mode applies when the application prefers a control signal from an external device, e.g., a network camera or a PIR detector.

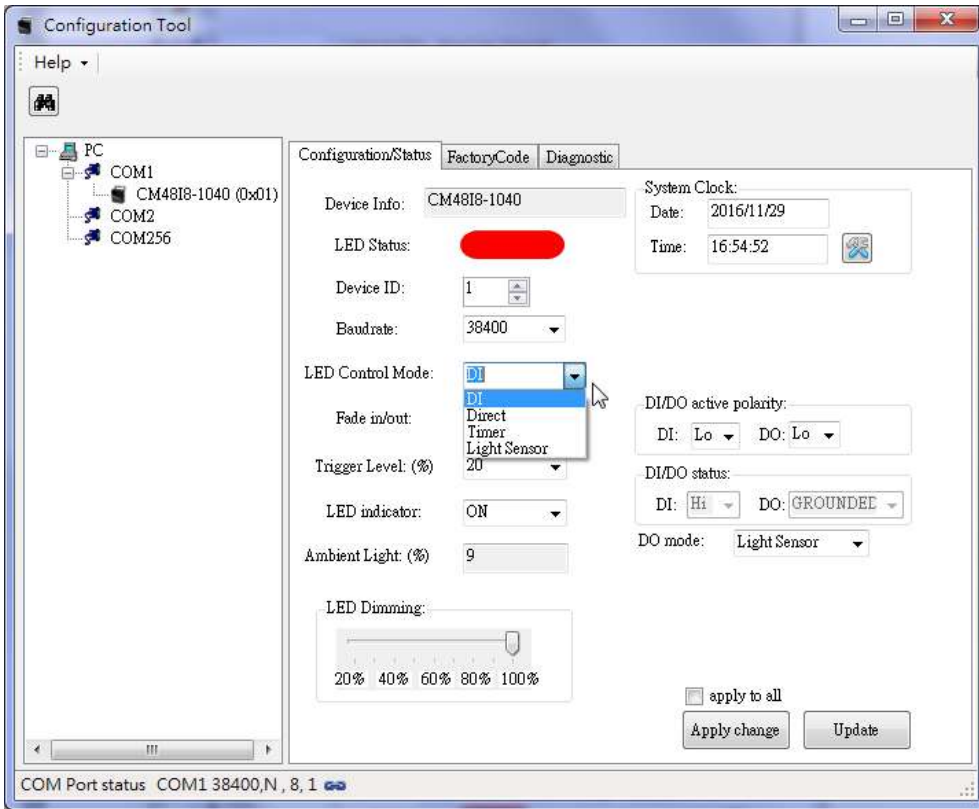

2.3.2 Direct mode

In the Direct control mode, the IR LED is controlled by the commands issued through the RS485 interface.

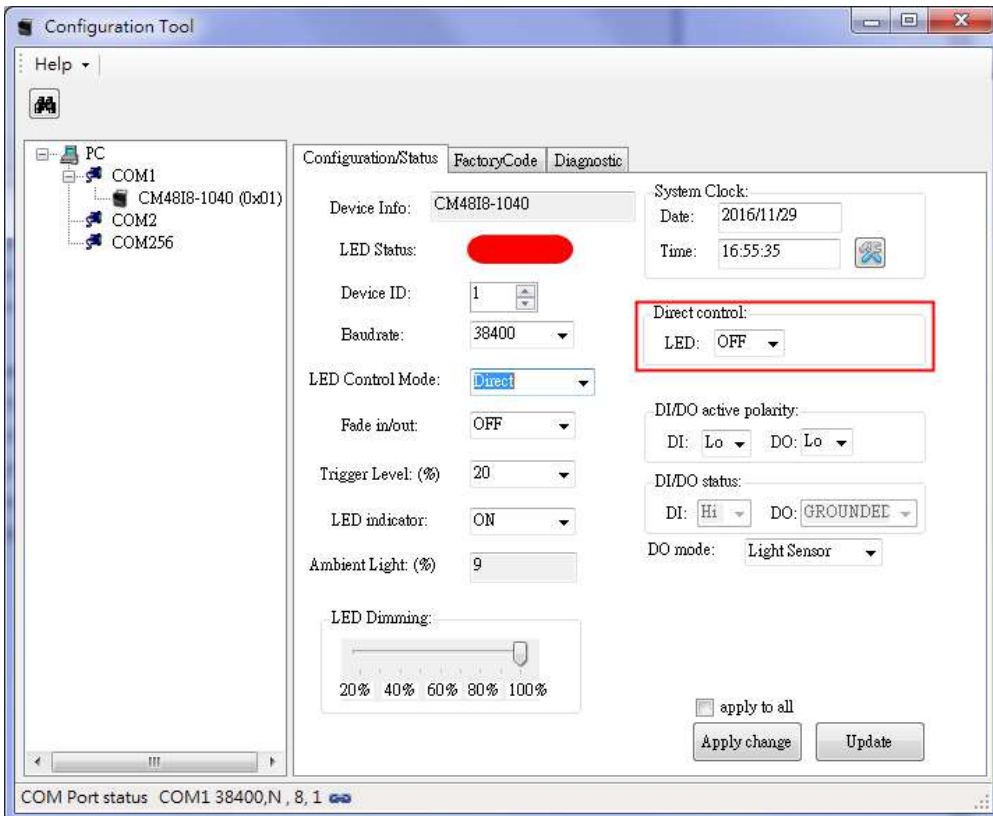

2.3.3 Timer mode

There is an embedded system clock on CaMate devices. The Timer mode allows the configuration of periodical ON/OFF time to control LED automatically. However, since there is no battery in CaMate, the system Clock will reset to default setting when powered down. (If you need to implement a battery to sustain the system clock during power-off, please contact your sales representative for customization service)

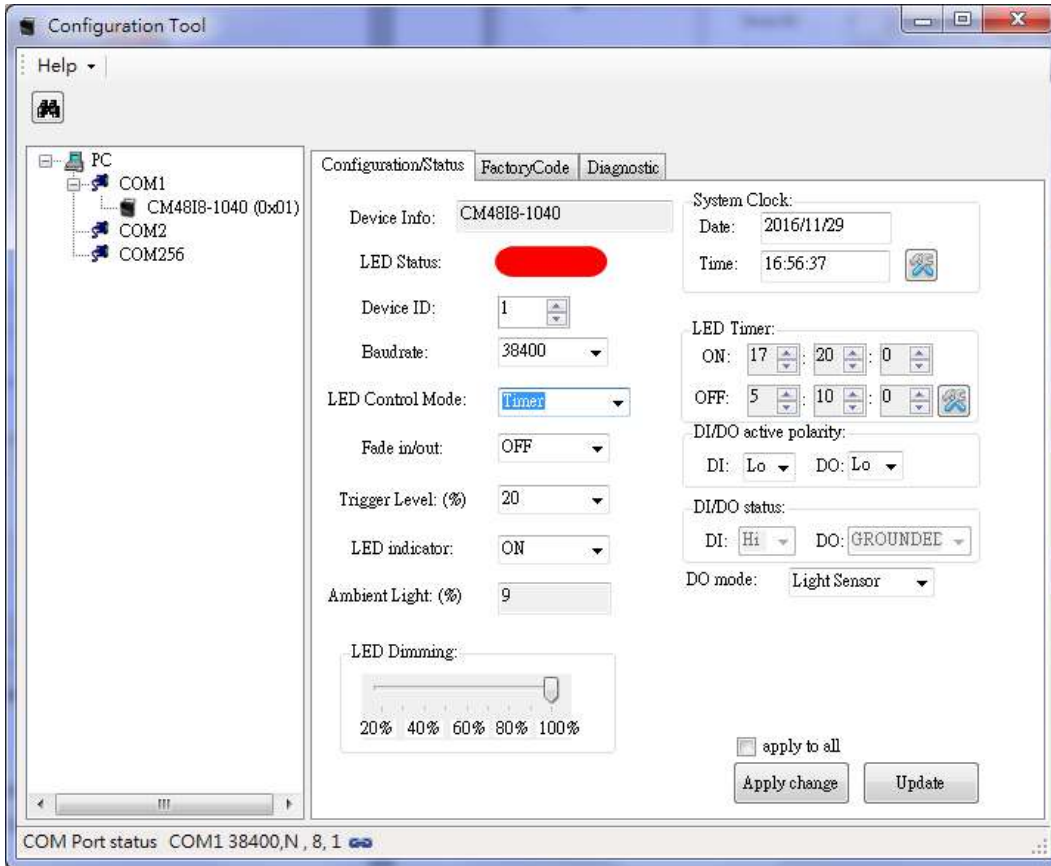

2.3.4 Light sensor mode

In the Light sensor mode, the LED is directly controlled by the light sensor status. If the Ambient Light is lower than the Trigger Level, LED turns ON. If higher than the Trigger level, the LED turns OFF.

2.4 Fade in/out

The Fade in/out control defines the LED ON/OFF behavior. If the Fade in/out function is disabled, the LED is turned ON or OFF immediately. When the Fade in/out is set to FAST, the LED fades in or out in 1 second, and 3 seconds if set to SLOW. Fade in/out can avoid sudden LED ON/OFF, which may cause the occurrence of over-exposure or under-exposure on camera image. The sudden ON/OFF will also cause discomfort for human eyes when using the visible light CaMate, such as the w5 series.

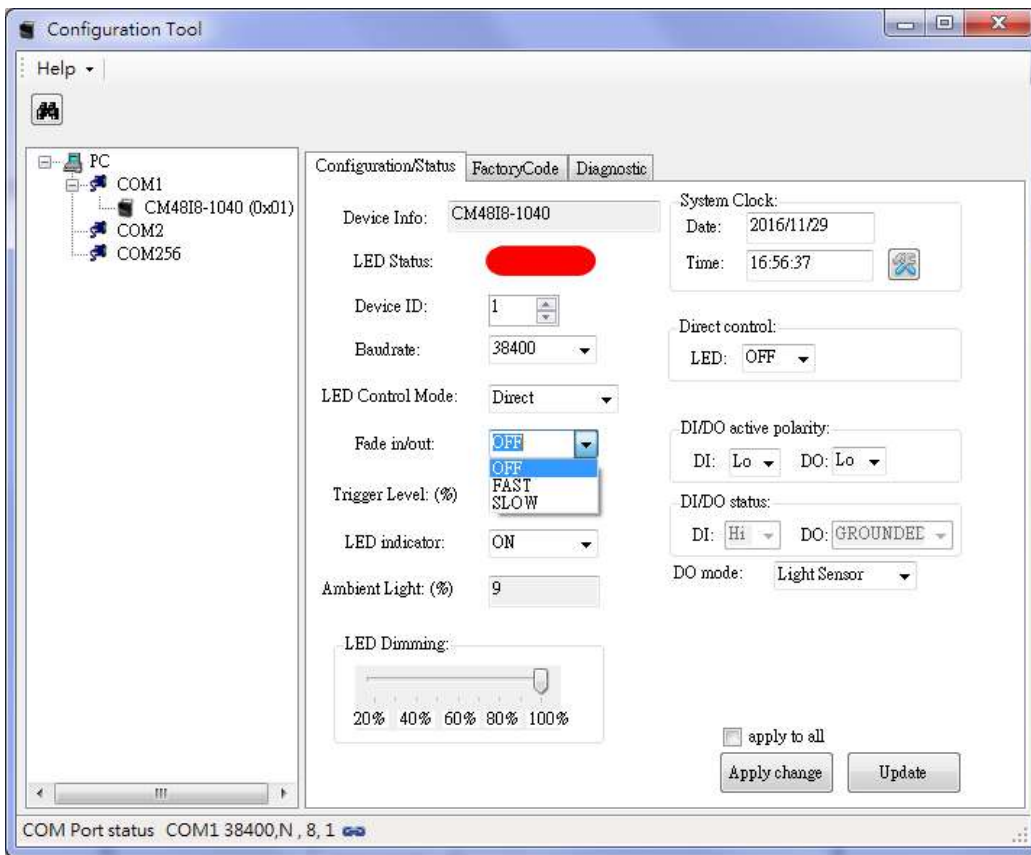

2.5 Trigger Level

Trigger Level defines the ambient Lux threshold for the embedded light sensor. There are 7 threshold levels. 20 % is the default value. " ∞ " represents the infinite value, which means the light sensor detection is always active. When the ambient light falls under the triggering threshold, the LEDs enter the active state, and will become inactive state when the light level is 10 % above the threshold, e.g., when the detected level is 30%.

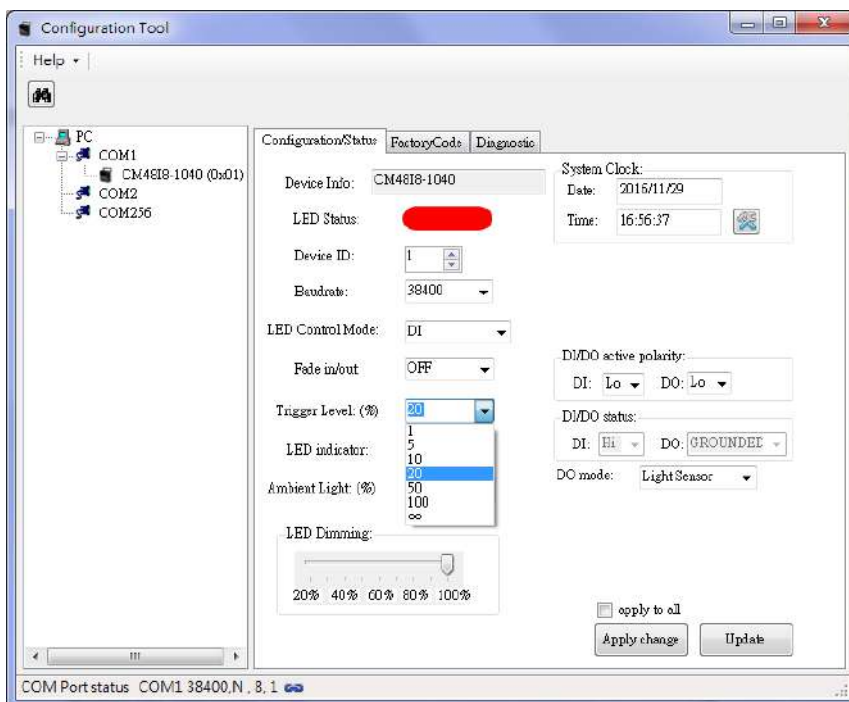

2.6 LED indicator

LED indicator activates or deactivates the information status LED, i.e. red and green LEDs (not the IR illumination LEDs). Because of opaque front cover in the IR models, I8 and I9, the LED indicators only can be seen in the non-IR CaMate products, i.e. w5. Below are the definitions of LED indicators:

- Red LED constant ON means normal operation, OFF means system is not working.
- Red LED flashes every 1 second means IR LEDs are overheated, flashes every 3 seconds means LED voltage is out of range.
- Green LED flashes means the device received and executing commands.
- If both red and green LEDs flash simultaneously, the device upgrading its firmware.

2.7 Ambient Light

Ambient Light reports the current ambient lighting level. The ambient light level is polled every 10 seconds. The light sensor detection control may have a max. of 10 seconds delay when the ambient light level changes.

2.8 LED Light Level

LED Light Level controls the strength of LED lighting from 100% (default setting, max. power consumption) to 20% when the LED is ON.

2.9 DO Mode

The DO mode defines the function of DO pin. The DO signal can be used to report three conditions: Detected Light Level, LED state, or Diagnostic mode. The DO pin signal follows the DO active polarity setting.

2.9.1 DO light sensor mode

In the default Light sensor mode, the DO pin outputs the light sensor detection result as the "bright" state (ambient lighting higher than the Triggering level) or the "dark" state (ambient light lower than the Triggering level). If the application requires CaMate to report Day/Night mode to other devices, e.g., the network camera, the DO mode should be configured to the Light sensor mode.

2.9.2 DO LED state mode

In the LED state mode, the DO pin outputs the LED ON/OFF state. If a CaMate is operating in the Direct or Light sensor LED control mode, other devices can acknowledge the CaMate's LED ON/OFF status via the DO connection.

2.9.3 DO Diagnostic mode

In the Diagnostic mode, the DO pin outputs the LED health status. Abnormal conditions may include: LEDs overheated or LED voltage out of range. The Diagnostic mode can be used for maintenance purpose.

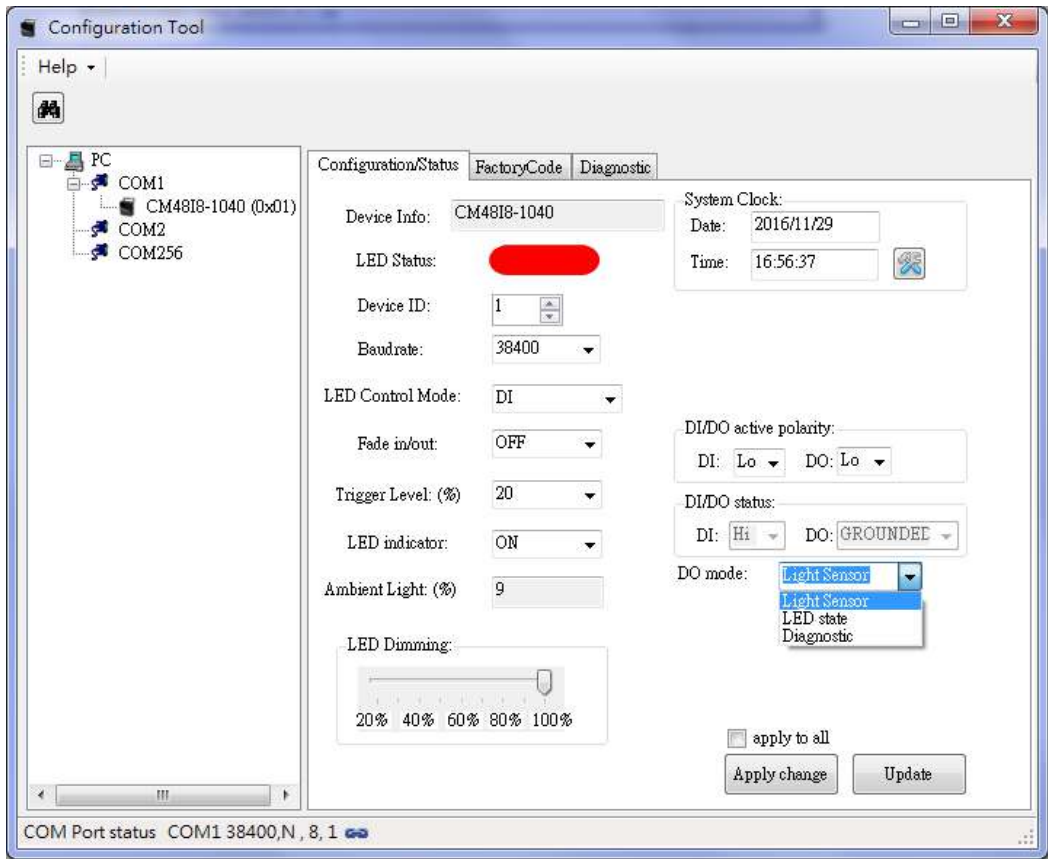

2.10 Angle Level (Only available for the motorized version of CaMate, e.g. CA4818-1040)

Angle level is used to adjust the beam angle of CaMate, and thus adjust the effective IR illumination range.

2.11 Diagnostic Page

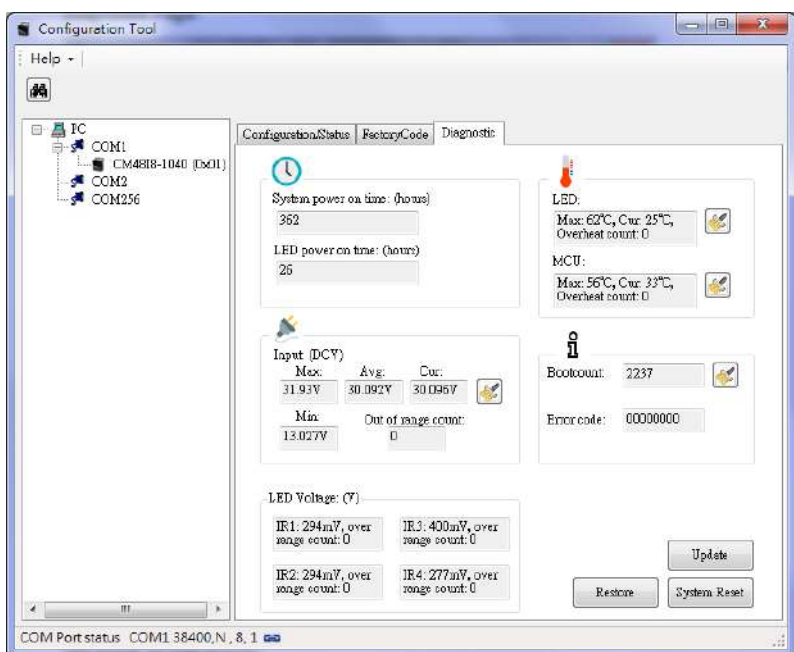

In the diagnostics page, you can find important system operating information.

2.11.1 System power on time (hours)

System power on time records total the accumulated number of operating hours.

2.11.2 LED power on time (hours)

LED power on time as the total LED ON hours.

2.11.3 Inputs

The Input state reports the input voltage of power supply to CaMate. It records the Max. and Min. voltage ever recorded, the average voltage during operation, and the current voltage reading. The Out of range count records the event when the input voltage is under DC12V -10% (DC10.8V) or over the AC24V+10% (AC26.4V).

2.11.4 LED Voltage

The LED voltage reports the health condition for LED strings, as there are 4 LED strings in CaMate. The normal LED ON voltage should fall between 400mV and 1200mV. The Over range count records the event when the detected LED voltage is over 1200mV. Once the LED voltage is over range, the LED is probably damaged. The 4 LED strings work independently.

2.11.5 LED Temperature

The LED temperature records the Max. temperature of LEDs ever happened, the current temperature, and the count of overheating events.

CaMate supports the automatic overheat protection when IR LED is overheated, i.e., over 95°C (203°F), by automatically reducing the current to maintain the LED working in a safe temperature range and to ensure the device reliability and longevity.

2.11.6 MCU Temperature

MCU temperature records the Max. temperature ever happened to MCU, current temperature reading, and the count of overheating events.

2.11.7 Boot count

How many times the device is power on and off. It can be used to check if power losses have occurred in the operation history.

2.11.8 Error code

The Error code is used for diagnostics purposes. You can report the error code to your technical support for help if the device is out of order.

2.12 Firmware Upgrade

CaMate's firmware can be upgraded through the RS485 interface. Access the firmware upgrade function in the Help menu.

Select Firmware Upgrade , the Firmware Upgrade window will prompt.

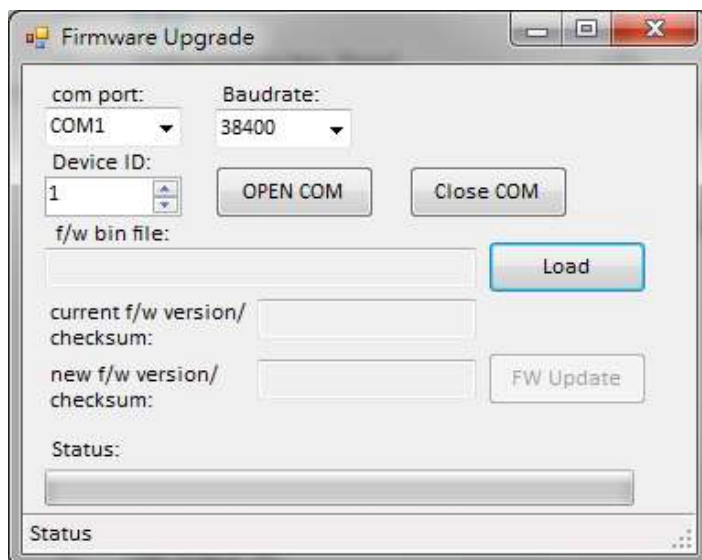
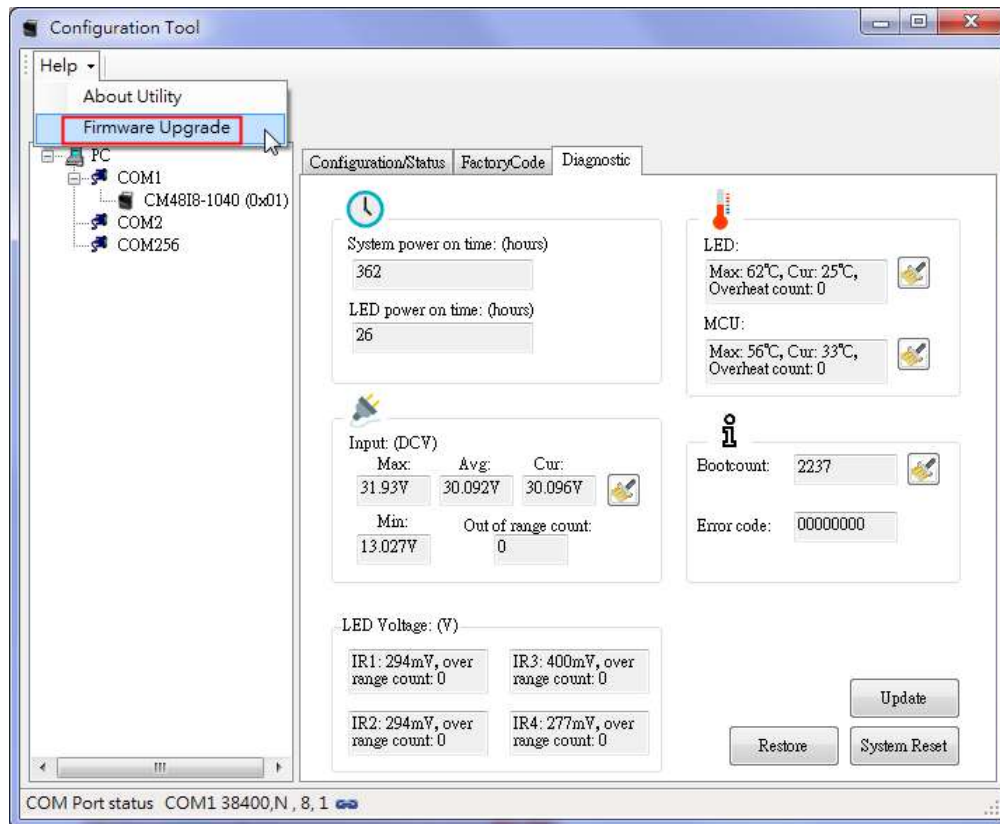

1. Select the correct COM port, Baudrate, and Device ID, then click the OPEN COM button. When a CaMate is connected, current firmware version and checksum will be read and shown.



If the software cannot connect to a CaMate, a timeout warning displays. Please check if the COM port and/or baudrate settings are correct, or the wire connection is correctly made.

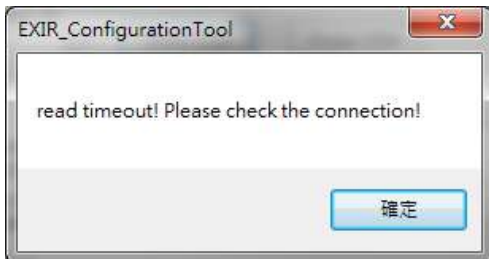

2. Load CaMate firmware binary code by clicking the Load button, and select the correct binary file. The new firmware version and checksum will display after loading.

You can find the firmware binary file at www.vivotek.com or contact your sales representative.

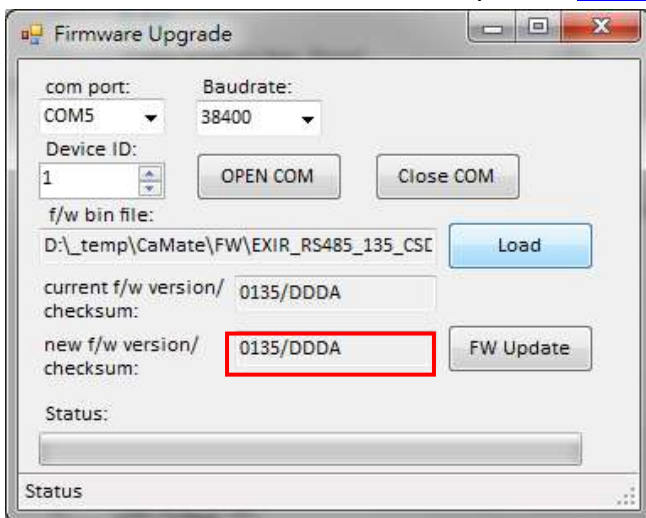

3. Click FW Update and confirm the upload, firmware upgrade will then start. Please do not turn off the power to CaMate until the upgrade is completed.

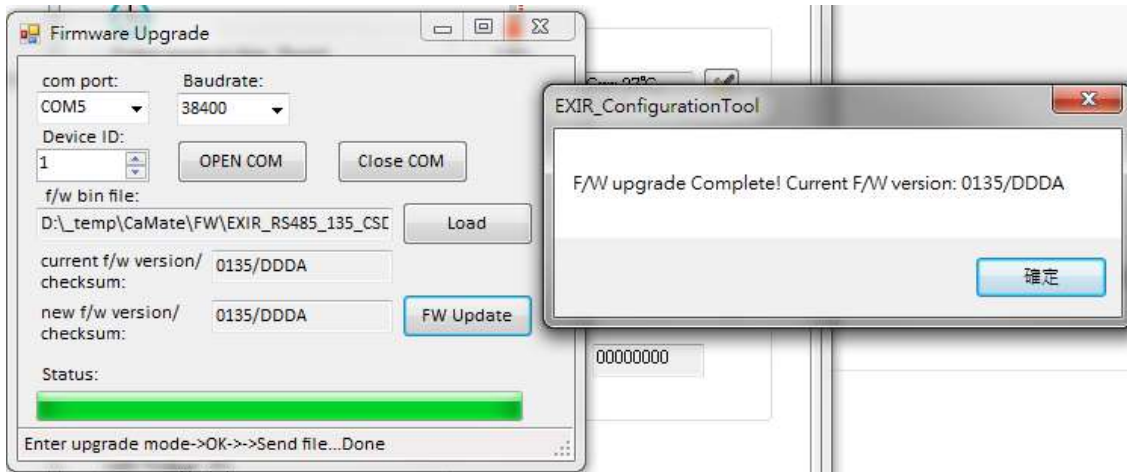

2.13 FactoryCode Page

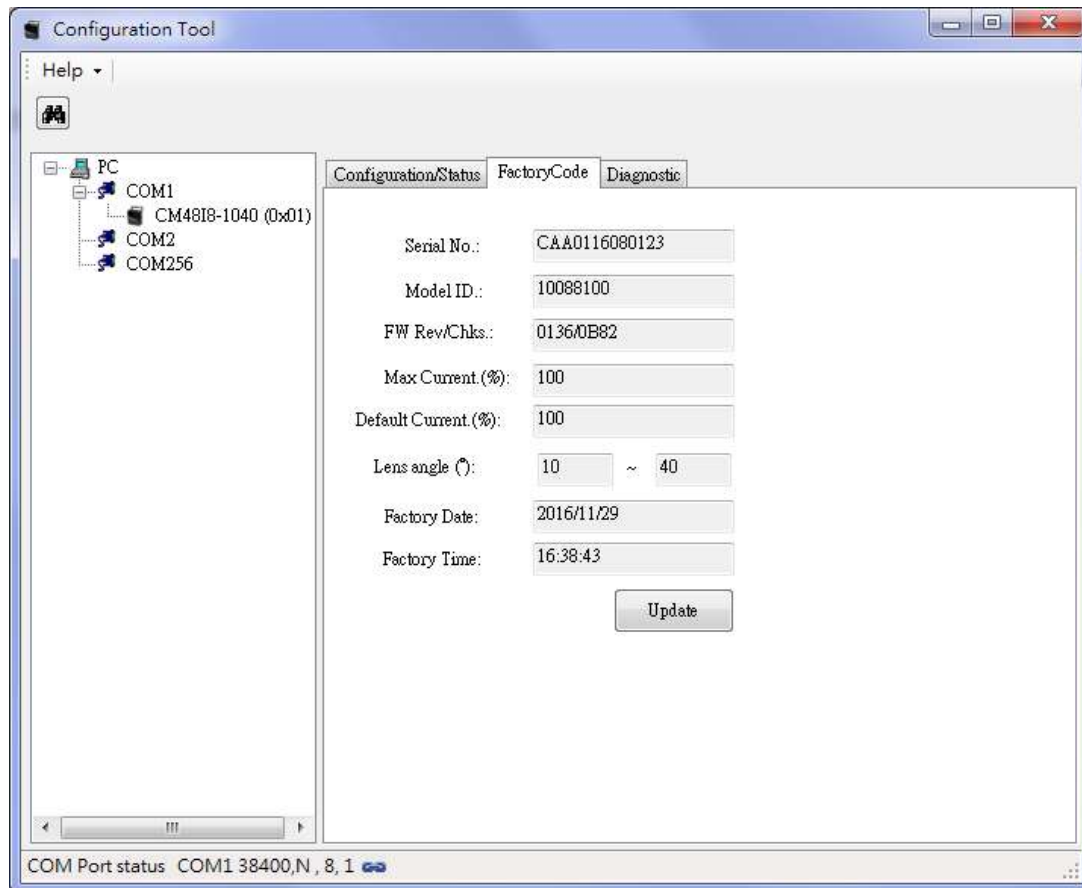

The FactoryCode page records manufacturing information of the device. Generally, the code is used for manufacturing.

Model ID

Model ID represents the model of CaMate.

FW Rev/Chks

Firmware revision and checksum of the code.

Max Current

Allowed max. LED current. It depends on hardware circuitry design.

Default Current

Default LED current configuration.

Lens angle

Optical Lens used in CaMate, e.g., $10^{\circ} \sim 40^{\circ}$.

Factory Date

Manufacturing date.

Factory Time

Manufacturing time.

3. Android APP

After you install CaMateTool.apk in your Android device, the app will automatically launch upon USB-to- RS485 converter connection. If not, tap the CaMate icon on the screen to launch.

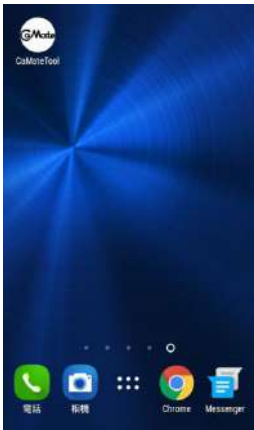

When CaMateTool screen appears, the app enables RS-485 communication using the default baud rate - 38,400 bps. The default device ID is 1. You can select a new one by touching the device ID value using a drop-down menu with all other available values. Then, click on the Update button, the app will query configuration status and display them on screen.

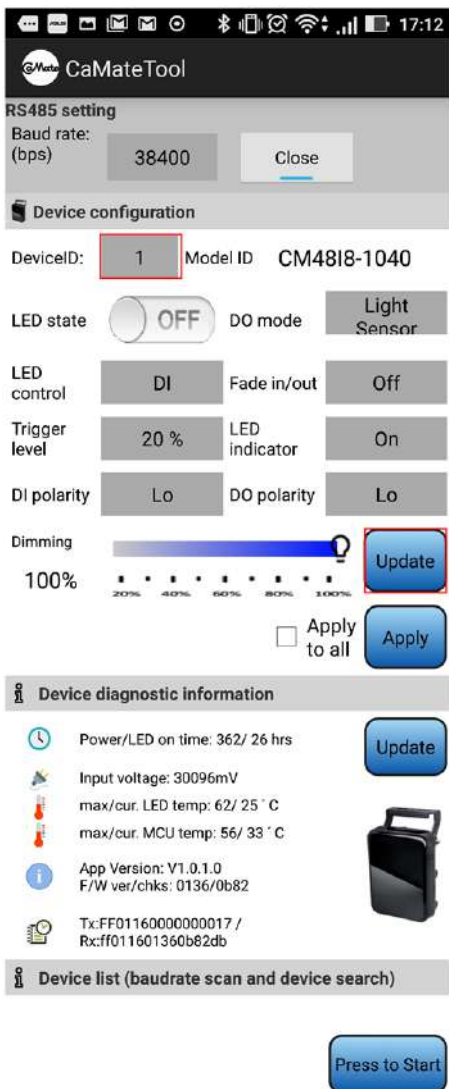

Device configuration

Device configuration

DeviceID: Model ID

LED state DO mode

LED control Fade in/out

Trigger level LED indicator

DI polarity DO polarity

Dimming

100% Apply to all

After the configuration value is changed, click the Apply changes button for the configuration changes to take effect. For the configuration details, please refer to the description in **Windows Application Software - Configuration/Status Page**.

Device diagnostic information

Device diagnostic information

 Power/LED on time: 362/ 26 hrs

 Input voltage: 30096mV

 max/cur. LED temp: 62/ 25 °C

 max/cur. MCU temp: 56/ 33 °C

 App Version: V1.0.1.0
F/W ver/chks: 0136/0b82

 Tx:FF01160000000017 /
Rx:ff011601360b82db



For the diagnostic information, please refer to the description in **Windows Application Software - Diagnostic Page**.

Device list (baudrate scan and device search)

Device list (baudrate scan and device search)

Start to scan Baudrate...

scan Baudrate:1200...

scan Baudrate:2400...

scan Baudrate:4800...

scan Baudrate:9600...

scan Baudrate:19200...

scan Baudrate:38400...CM48I8-1040 ← correct baudrate

scan Baudrate:57600...

scan Baudrate:115200...

Start to search device...

Inquiry ID:0...

Inquiry ID:1...CM48I8-1040 ← device is found

Inquiry ID:2...

Inquiry ID:3...

Inquiry ID:4...



If you are not sure of the baudrate or device ID of CaMate, you can scroll down on the screen, click the Press to Start button to search for correct baudrate and device ID. You can click Press to Stop button to stop scanning anytime once your CaMate is found.

4. Remote Controller



Unlock



By default, the CaMate IR remote control is disabled. To enable the control function, the unlock button must be pressed continuously for at least 2 seconds. After being idle for 5 minutes, it automatically enters the lock mode to disable IR remote control function.

LED on/off



The button is a toggle switch to turn LEDs on/off.

LED status



The button is a toggle switch to turn status LED indicators on/off. Because of the opaque front cover in the IR version, I8 and I9, the LED indicators only can be seen in the non-IR CaMate products, i.e. w5.

Light sensor sensitivity

There are three pre-defined levels to configure the light sensor threshold values.



Turn LED on when the ambient light is under 50 % and turn off when the ambient light is above 60%.



Turn LED on when ambient light is under 20 % and turn off when the ambient light is above 30 %.



Turn LED on when ambient light is under 10 % and turn off when the ambient light is above 20 %.

LED dimming

There are four pre-defined levels to configure the strength of LED lighting.



100%



75%



50 %



25%

The fine-tune button set the strength of LED lighting from 100% to 20%.



Angle of illuminator

(Only available for the motorized version of CaMate, e.g. CM48I8A-1040). The Angle level is used to adjust the beam angle of CaMate for variable effective illumination distances.



Adjusts angle to tele



Adjusts angle to 66%



Adjusts angle to 33%



Adjusts angle to wide



Adjusts angle to tele (fine-tune)



Adjusts angle to wide (fine-tune)

5. Appendix

5.1 Appendix A: Pelco-D set of CaMate

Standard Commands

The Cmd2 of standard commands is always even. Responses are suppressed for standard commands because some controllers output many repeated commands in rapid succession without sufficiently delaying for a response to be sent between commands.

Extended Commands

The Cmd2 of Extended commands is always odd.

5.1.0 Use Windows Application Software to get commands

1. First select the command generator.

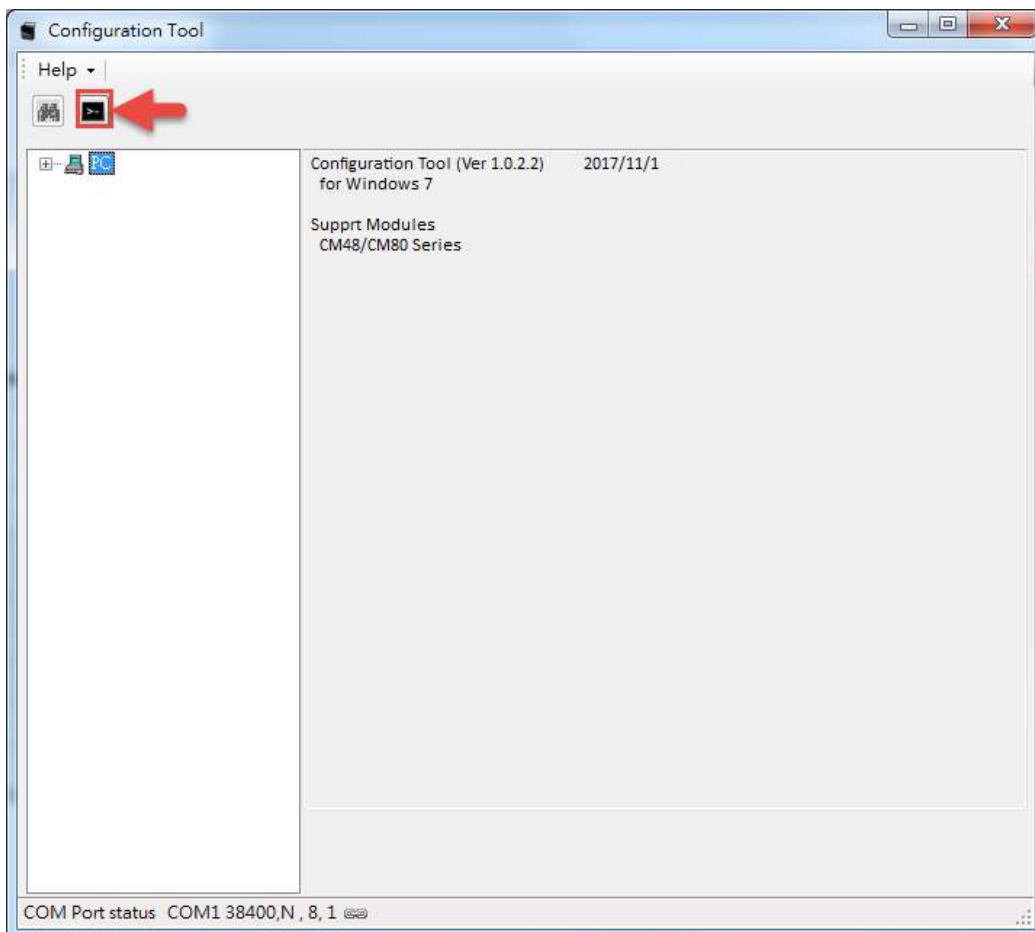

2. Then, select Model information and the commands you want. The correspond Pelco-D command will shown on the right

The screenshot shows the 'Form_Commander' application window. It is divided into three main sections:

- Step1: Identify your device**: Contains dropdown menus for 'series' (with a dropdown menu open showing options: CM48, CM48, CM80, CA80), 'light source' (I8), 'angle' (1040), and a 'default id' field (1).
- Step2: Select parameters in below function list**: A list of parameters with dropdown menus and arrows pointing to the right:
 - LED Control Mode: DI
 - DO Mode: Light Sensor
 - LED Brightness: 100
 - Light sensor trigger level (%): 30
 - hysteresis (%): 30 / oversample: 3
 - DIO Polarity: DI: Lo, DO: Lo
 - Fade in/out: OFF
 - LED indicator: ON
- Step3: Generator Pelco-D command**: A list of text input fields containing the corresponding Pelco-D commands for each parameter in Step 2:
 - FF01826D0000F0
 - FF01886D0000F6
 - FF01007D0064E2
 - FF01007F001E9E
 - FF01A26D1E0331
 - FF01866D0000F4
 - FF01846D0000F2
 - FF018C6D0001FB

3. Copy and paste to command line on web page

The screenshot shows a web browser window titled 'Custom command - Internet Explorer' with the URL 'http://192.168.161.101/setup/ptz/custom_cmd.html?CustomDriver=false'. The page content is as follows:

Custom command

Leaving the "Button name" field empty means the command button will not be displayed in the homepage.

	Button name	Command
Command 1:	Brightness 100%	FF01007D0064E2
Command 2:	Brightness 80%	FF01007D0050CE
Command 3:	Brightness 50%	FF01007D0032B0
Command 4:	Light sensor 10%	FF01007F000A8A
Command 5:	Light sensor 5%	FF01007F00058A

At the bottom of the form, there are 'Save' and 'Close' buttons.

5.1.1 Soft reset (0x0F)

Byte number	1	2	3	4	5	6	7
Byte Definition	Sync	Addr	Cmd1	Cmd2	Data1	Data2	ChkSum
Set LED control mode	0xFF	0x01	0x00	0x0F	0x00	0x00	--

Response Format:

Byte number	1	2	3	4
Byte Definition	Sync	Addr	Faults	ChkSum
General Response	0xFF	0x01	--	--

5.1.2 Reset to default (0x29)

Byte number	1	2	3	4	5	6	7
Byte Definition	Sync	Addr	Cmd1	Cmd2	Data1	Data2	ChkSum
Set LED control mode	0xFF	0x01	0x00	0x29	0x00	0x00	--

Response Format:

Byte number	1	2	3	4
Byte Definition	Sync	Addr	Faults	ChkSum
General Response	0xFF	0x01	--	--

5.1.3 Set zoom position (0x4F)

The command set CaMate's zoom position to an absolute value from 0-100%. The position is sent as a 16-bit value in Data1 and Data2, scaled by 65535(0xFFFF).

Byte number	1	2	3	4	5	6	7
Byte Definition	Sync	Addr	Cmd1	Cmd2	Data1	Data2	ChkSum
Set LED control mode	0xFF	0x01	0x00	0x4F	Zoom % MSB	Zoom % LSB	--

Response Format:

Byte number	1	2	3	4
Byte Definition	Sync	Addr	Faults	ChkSum
General Response	0xFF	0x01	--	--

5.1.4 Get zoom position (0x55)

This command returns CaMate's current zoom position.

Command format:

Byte number	1	2	3	4	5	6	7
Byte Definition	Sync	Addr	Cmd1	Cmd2	Data1	Data2	ChkSum
Query LED control mode	0xFF	0x01	0x00	0x55	0x00	0x00	--

Response Format:

Byte number	1	2	3	4	5	6	7
Byte Definition	Sync	Addr	Resp1	Resp2	Data1	Data2	ChkSum
Extended Response	0xFF	0x01	0x00	0x5D	Zoom % MSB	Zoom % LSB	--

5.1.5 Set Baud rate (0x67)

The command will change CaMate's baud rate.

Byte number	1	2	3	4	5	6	7
Byte Definition	Sync	Addr	Cmd1	Cmd2	Data1	Data2	ChkSum
Set LED control mode	0xFF	0x01	0x00	0x67	0x00	Baud rate	--

Response Format:

Byte number	1	2	3	4
Byte Definition	Sync	Addr	Faults	ChkSum
General Response	0xFF	0x01	--	--

0x00 Baud rate: 1200 bps

0x04 Baud rate: 19200 bps

0x01 Baud rate: 2400 bps

0x05 Baud rate: 38400 bps

0x02 Baud rate: 4800 bps

0x06 Baud rate: 57600 bps

0x03 Baud rate: 9600 bps

0x07 Baud rate: 115200 bps

5.1.6 Query device type (0x6B)

This command returns CaMate's model ID.

Command format:

Byte number	1	2	3	4	5	6	7
Byte Definition	Sync	Addr	Cmd1	Cmd2	Data1	Data2	ChkSum
Query LED control mode	0xFF	0x01	0x00	0x6B	0x00	0x00	--

Response Format:

Byte number	1	2	3	4	5	6	7
Byte Definition	Sync	Addr	Resp1	Resp2	Data1	Data2	ChkSum
Extended Response	0xFF	0x01	Model ID byte3	Model ID byte2	Model ID byte1	Model ID byte0	--

5.1.7 Set/Read Configuration information (0x6D)

This command sets/returns CaMate's LED control mode, DIO's polarity, DO mode, device ID address, LED status, LED indicator on/off control.

5.1.7.1 LED control mode

There are 4 control modes of LED, i.e. DI, Direct, Timer, and Light sensor.

DI mode (default): in this mode, LED on/off is controlled by DI signal

Direct mode: LED on/off is controlled by command through RS485

Timer mode: set the periodical on/off time to control LED automatically

Light sensor mode: LED is controlled by light sensor status. If ambient light is lower than threshold level, LED turns on, else off.

Command format: **Get**

Byte number	1	2	3	4	5	6	7
Byte Definition	Sync	Addr	Cmd1	Cmd2	Data1	Data2	ChkSum
Query LED control mode	0xFF	0x01	0x02	0x6D	0x00	0x00	--

Response Format:

Byte number	1	2	3	4	5	6	7
Byte Definition	Sync	Addr	Resp1	Resp2	Data1	Data2	ChkSum
Extended Response	0xFF	0x01	0x00	0x00	0x00	LED ctrl mode	--

LED ctrl mode: (0)DI/(1)Direct/(2)Timer/(3) Light Sensor

Command format: **Set**

Byte number	1	2	3	4	5	6	7
Byte Definition	Sync	Addr	Cmd1	Cmd2	Data1	Data2	ChkSum
Set LED control mode	0xFF	0x01	0x82	0x6D	0x00	LED ctrl mode	--

Response Format:

Byte number	1	2	3	4
Byte Definition	Sync	Addr	Faults	ChkSum
General Response	0xFF	0x01	--	--

5.1.7.2 Fade in/out control

Fade in/out control the on/off behavior of LED, to avoid sudden LED on/off at which may cause camera over-exposure or under-exposure.

Off: the LED is on or off immediately.

Fast: the LED fades in or out in 1 second.

Slow: the LED fades in or out in 3 seconds.

Command format: **Get**

Byte number	1	2	3	4	5	6	7
Byte Definition	Sync	Addr	Cmd1	Cmd2	Data1	Data2	ChkSum
Query Fade in/out	0xFF	0x01	0x04	0x6D	0x00	0x00	--

Response Format:

Byte number	1	2	3	4	5	6	7
Byte Definition	Sync	Addr	Resp1	Resp2	Data1	Data2	ChkSum
Extended Response	0xFF	0x01	0x00	0x00	0x00	LED fade in/out	--

Fade in/out: (0) off / (1) Fast/ (2) Slow

Command format: **Set**

Byte number	1	2	3	4	5	6	7
Byte Definition	Sync	Addr	Cmd1	Cmd2	Data1	Data2	ChkSum
Set Fade in/out	0xFF	0x01	0x84	0x6D	0x00	LED fade in/out	--

Response Format:

Byte number	1	2	3	4
Byte Definition	Sync	Addr	Faults	ChkSum
General Response	0xFF	0x01	--	--

5.1.7.3 DI/DO active polarity

Command format: **Get**

Byte number	1	2	3	4	5	6	7
Byte Definition	Sync	Addr	Cmd1	Cmd2	Data1	Data2	ChkSum
Query DIO's polarity	0xFF	0x01	0x06	0x6D	0x00	0x00	--

Response Format:

Byte number	1	2	3	4	5	6	7
Byte Definition	Sync	Addr	Resp1	Resp2	Data1	Data2	ChkSum
Extended Response	0xFF	0x01	0x00	DI's polarity	0x00	DO's polarity	--

DIO's active polarity: (0)Lo/(1)Hi

Command format: **Set**

Byte number	1	2	3	4	5	6	7
Byte Definition	Sync	Addr	Cmd1	Cmd2	Data1	Data2	ChkSum
Set DIO's polarity	0xFF	0x01	0x86	0x6D	DI's polarity	DO's polarity	--

Response Format:

Byte number	1	2	3	4
Byte Definition	Sync	Addr	Faults	ChkSum
General Response	0xFF	0x01	--	--

5.1.7.4 DO mode

DO mode defines the function of DO pin, there are three modes.

Light sensor: DO pin outputs the light sensor detection result.

LED state: DO pin outputs the LED on/off state.

Diagnostic: DO pin outputs the health condition of LED for maintenance purpose.

Command format: **Get**

Byte number	1	2	3	4	5	6	7
Byte Definition	Sync	Addr	Cmd1	Cmd2	Data1	Data2	ChkSum
Query DO mode	0xFF	0x01	0x08	0x6D	0x00	0x00	--

Response Format:

Byte number	1	2	3	4	5	6	7
Byte Definition	Sync	Addr	Resp1	Resp2	Data1	Data2	ChkSum
Extended Response	0xFF	0x01	0x00	0x00	0x00	DO mode	--

DO mode: (0) Light sensor state/ (1) LED state/ (2) Diagnostic

Command format: **Set**

Byte number	1	2	3	4	5	6	7
Byte Definition	Sync	Addr	Cmd1	Cmd2	Data1	Data2	ChkSum
Set DO mode	0xFF	0x01	0x88	0x6D	0x00	DO mode	--

Response Format:

Byte number	1	2	3	4
Byte Definition	Sync	Addr	Faults	ChkSum
General Response	0xFF	0x01	--	--

5.7.1.5 LED on/off

When LED control mode is in direct mode, this command set CaMate to turn on or off.

Command format: **Get**

Byte number	1	2	3	4	5	6	7
Byte Definition	Sync	Addr	Cmd1	Cmd2	Data1	Data2	ChkSum
Query LED on/off status	0xFF	0x01	0x0A	0x6D	0x00	0x00	--

Response Format:

Byte number	1	2	3	4	5	6	7
Byte Definition	Sync	Addr	Resp1	Resp2	Data1	Data2	ChkSum
Extended Response	0xFF	0x01	0x00	0x00	0x00	LED on/off	--

LED on/off state: (0) off/ (1) on

Command format: **Set**

Byte number	1	2	3	4	5	6	7
Byte Definition	Sync	Addr	Cmd1	Cmd2	Data1	Data2	ChkSum
Set LED on/off status	0xFF	0x01	0x8A	0x6D	0x00	LED on/off	--

Response Format:

Byte number	1	2	3	4
Byte Definition	Sync	Addr	Faults	ChkSum
General Response	0xFF	0x01	--	--

Read-only if LED control is not in direct mode.

5.1.7.6 Indicator on/off

LED indicators activate or deactivate the information status LED. If indicator is on, the meanings of LED is as below.

- If red LED keeps ON means normal, keeps OFF means system is not working.
- If red LED flashes every 1 second means LED is overheat, flashes every 3 seconds means LED voltage is out of range.
- Green LED flashes means the device received and executed commands.
- If both red and green LEDs flash simultaneously, the device is in firmware upgrade mode.

Command format: **Get**

Byte number	1	2	3	4	5	6	7
Byte Definition	Sync	Addr	Cmd1	Cmd2	Data1	Data2	ChkSum
Query indicator on/off	0xFF	0x01	0x0C	0x6D	0x00	0x00	--

Response Format:

Byte number	1	2	3	4	5	6	7
Byte Definition	Sync	Addr	Resp1	Resp2	Data1	Data2	ChkSum
Extended Response	0xFF	0x01	0x00	0x00	0x00	Indicator on/off	--

LED on/off state: (0) off/ (1) on

Command format: **Set**

Byte number	1	2	3	4	5	6	7
Byte Definition	Sync	Addr	Cmd1	Cmd2	Data1	Data2	ChkSum
Set indicator on/off	0xFF	0x01	0x8C	0x6D	0x00	indicator on/off	--

Response Format:

Byte number	1	2	3	4
Byte Definition	Sync	Addr	Faults	ChkSum
General Response	0xFF	0x01	--	--

5.1.7.7 Device ID address

Command format: **Get**

Byte number	1	2	3	4	5	6	7
Byte Definition	Sync	Addr	Cmd1	Cmd2	Data1	Data2	ChkSum
Query device ID address	0xFF	0x01	0x0E	0x6D	0x00	0x00	--

Response Format:

Byte number	1	2	3	4	5	6	7
Byte Definition	Sync	Addr	Resp1	Resp2	Data1	Data2	ChkSum
Extended Response	0xFF	0x01	0x00	0x00	0x00	Device ID address	--

Device ID address: 1~127

Command format: **Set**

Byte number	1	2	3	4	5	6	7
Byte Definition	Sync	Addr	Cmd1	Cmd2	Data1	Data2	ChkSum
Set device ID address	0xFF	0x01	0x8E	0x6D	0x00	Device ID address	--

Response Format:

Byte number	1	2	3	4
Byte Definition	Sync	Addr	Faults	ChkSum
General Response	0xFF	0x01	--	--

5.1.7.8 Clock time

This command returns the time of clock in MCU. Due to no battery is installed in CaMate, the clock data will reset if power is off.

Command format: **Get**

Byte number	1	2	3	4	5	6	7
Byte Definition	Sync	Addr	Cmd1	Cmd2	Data1	Data2	ChkSum
Query Clock time	0xFF	0x01	0x14	0x6D	0x00	0x00	--

Response Format:

Byte number	1	2	3	4	5	6	7
Byte Definition	Sync	Addr	Resp1	Resp2	Data1	Data2	ChkSum
Extended Response	0xFF	0x01	0x00	Hour	Minute	Second	--

Command format: **Set**

Byte number	1	2	3	4	5	6	7
Byte Definition	Sync	Addr	Cmd1	Cmd2	Data1	Data2	ChkSum
Set Clock time - hour	0xFF	0x01	0x94	0x6D	0x00	Hour	--
Byte number	1	2	3	4	5	6	7

Byte Definition	Sync	Addr	Cmd1	Cmd2	Data1	Data2	ChkSum
Set Clock time – min/sec	0xFF	0x01	0x96	0x6D	Minute	Second	--

Response Format:

Byte number	1	2	3	4
Byte Definition	Sync	Addr	Faults	ChkSum
General Response	0xFF	0x01	--	--

5.1.7.9 Timer LED on

These commands return or set the periodical time of LED on.

Command format: **Get**

Byte number	1	2	3	4	5	6	7
Byte Definition	Sync	Addr	Cmd1	Cmd2	Data1	Data2	ChkSum
Query timer LED on	0xFF	0x01	0x18	0x6D	0x00	0x00	--

Response Format:

Byte number	1	2	3	4	5	6	7
Byte Definition	Sync	Addr	Resp1	Resp2	Data1	Data2	ChkSum
Extended Response	0xFF	0x01	0x00	Hour	Minute	Second	--

Command format: **Set**

Byte number	1	2	3	4	5	6	7
Byte Definition	Sync	Addr	Cmd1	Cmd2	Data1	Data2	ChkSum
Set timer LED on - hour	0xFF	0x01	0x98	0x6D	0x00	Hour	--
Byte number	1	2	3	4	5	6	7
Byte Definition	Sync	Addr	Cmd1	Cmd2	Data1	Data2	ChkSum
Set timer LED on – min/sec	0xFF	0x01	0x9A	0x6D	Minute	Second	--

Response Format:

Byte number	1	2	3	4
Byte Definition	Sync	Addr	Faults	ChkSum
General Response	0xFF	0x01	--	--

5.1.7.10 Timer LED off

These commands return or set the periodical time of LED off.

Command format: **Get**

Byte number	1	2	3	4	5	6	7
Byte Definition	Sync	Addr	Cmd1	Cmd2	Data1	Data2	ChkSum
Query timer LED off	0xFF	0x01	0x1C	0x6D	0x00	0x00	--

Response Format:

Byte number	1	2	3	4	5	6	7
Byte Definition	Sync	Addr	Resp1	Resp2	Data1	Data2	ChkSum
Extended Response	0xFF	0x01	0x00	Hour	Minute	Second	--

Command format: **Set**

Byte number	1	2	3	4	5	6	7
Byte Definition	Sync	Addr	Cmd1	Cmd2	Data1	Data2	ChkSum
Set timer LED off - hour	0xFF	0x01	0x9C	0x6D	0x00	Hour	--
Byte number	1	2	3	4	5	6	7
Byte Definition	Sync	Addr	Cmd1	Cmd2	Data1	Data2	ChkSum
Set timer LED off – min/sec	0xFF	0x01	0x9E	0x6D	Minute	Second	--

Response Format:

Byte number	1	2	3	4
Byte Definition	Sync	Addr	Faults	ChkSum
General Response	0xFF	0x01	--	--

5.1.7.11 DI/DO status

Command format: **Get**

Byte number	1	2	3	4	5	6	7
Byte Definition	Sync	Addr	Cmd1	Cmd2	Data1	Data2	ChkSum
Query DIO status	0xFF	0x01	0x20	0x6D	0x00	0x00	--

Response Format:

Byte number	1	2	3	4	5	6	7
Byte Definition	Sync	Addr	Resp1	Resp2	Data1	Data2	ChkSum
Extended Response	0xFF	0x01	0x00	0x24	DI state	DO state	--

DIO's state: (0) Lo/ (1) Hi

5.1.7.12 Hysteresis/Oversample of light sensor trigger

Command format: **Get**

Byte number	1	2	3	4	5	6	7
Byte Definition	Sync	Addr	Cmd1	Cmd2	Data1	Data2	ChkSum
Query ambient hysteresis/oversample	0xFF	0x01	0x22	0x6D	0x00	0x00	--

Response Format:

Byte number	1	2	3	4	5	6	7
Byte Definition	Sync	Addr	Resp1	Resp2	Data1	Data2	ChkSum
Extended Response	0xFF	0x01	0x00	0x26	Hysteresis	Oversample	--

Command format: **Set**

Byte number	1	2	3	4	5	6	7
Byte Definition	Sync	Addr	Cmd1	Cmd2	Data1	Data2	ChkSum
Set ambient hysteresis/oversample	0xFF	0x01	0xA2	0x6D	Hysteresis	Oversample	--

Response Format:

Byte number	1	2	3	4
Byte Definition	Sync	Addr	Faults	ChkSum
General Response	0xFF	0x01	--	--

5.1.8 Query Diagnostic information (0x6F)

This command returns CaMate's temperature information, input voltage information, total system power on time, total LED power on time, current ambient light, boot count, LED1~4 voltage, system error code, out of range count.

5.1.8.1 Temperature of LED/MCU

Command format: **Get**

Byte number	1	2	3	4	5	6	7
Byte Definition	Sync	Addr	Cmd1	Cmd2	Data1	Data2	ChkSum
Query temperature	0xFF	0x01	0x02	0x6F	0x00	0x00	--

Response Format:

Byte number	1	2	3	4	5	6	7
Byte Definition	Sync	Addr	Resp1	Resp2	Data1	Data2	ChkSum
Extended Response	0xFF	0x01	LED Max	LED Current	MCU Max	MCU Current	--

Temperature value is in 2's complement.

Command format: **Clear:**

Byte number	1	2	3	4	5	6	7
Byte Definition	Sync	Addr	Cmd1	Cmd2	Data1	Data2	ChkSum
Clear temperature	0xFF	0x01	0x82	0x6F	LED Max	MCU Max	--

Response Format:

Byte number	1	2	3	4
Byte Definition	Sync	Addr	Faults	ChkSum
General Response	0xFF	0x01	--	--

Set LED/MCU Max bit with 1 to clear max record

5.1.8.2 Measurement of Input voltage

Command format: **Get**

Byte number	1	2	3	4	5	6	7
Byte Definition	Sync	Addr	Cmd1	Cmd2	Data1	Data2	ChkSum
Query max/avg. input voltage	0xFF	0x01	0x04	0x6F	0x00	0x00	--

Response Format:

Byte number	1	2	3	4	5	6	7
Byte Definition	Sync	Addr	Resp1	Resp2	Data1	Data2	ChkSum
Extended Response	0xFF	0x01	Max. MSB	Max. LSB	Average MSB	Average LSB	--

Voltage value is in mV

Command format: **Clear:**

Byte number	1	2	3	4	5	6	7
Byte Definition	Sync	Addr	Cmd1	Cmd2	Data1	Data2	ChkSum
Clear max/avg. input voltage	0xFF	0x01	0x84	0x6F	0x00	0x00	--

Response Format:

Byte number	1	2	3	4
Byte Definition	Sync	Addr	Faults	ChkSum
General Response	0xFF	0x01	--	--

Command format: **Get:**

Byte number	1	2	3	4	5	6	7
Byte Definition	Sync	Addr	Cmd1	Cmd2	Data1	Data2	ChkSum
Query current/min. input voltage	0xFF	0x01	0x06	0x6F	0x00	0x00	--

Response Format:

Byte number	1	2	3	4	5	6	7
Byte Definition	Sync	Addr	Resp1	Resp2	Data1	Data2	ChkSum
Extended Response	0xFF	0x01	current MSB	current LSB	Min MSB	Min LSB	--

Voltage value is in mV

5.1.8.3 Total System power on time

Command format: **Get**

Byte number	1	2	3	4	5	6	7
Byte Definition	Sync	Addr	Cmd1	Cmd2	Data1	Data2	ChkSum
Query total system power on time	0xFF	0x01	0x08	0x6F	0x00	0x00	--

Response Format:

Byte number	1	2	3	4	5	6	7
Byte Definition	Sync	Addr	Resp1	Resp2	Data1	Data2	ChkSum
Extended Response	0xFF	0x01	Sys. time Byte3	Sys. time Byte2	Sys. time Byte1	Sys. time Byte0	--

System power on time: [Byte3] [Byte2] [Byte1] [Byte0] $0 \sim 2^{32}$ hours

5.1.8.4 Total LED power on time

Command format: **Get**

Byte number	1	2	3	4	5	6	7
Byte Definition	Sync	Addr	Cmd1	Cmd2	Data1	Data2	ChkSum
Query total LED power on time	0xFF	0x01	0x0A	0x6F	0x00	0x00	--

Response Format:

Byte number	1	2	3	4	5	6	7
Byte Definition	Sync	Addr	Resp1	Resp2	Data1	Data2	ChkSum
Extended Response	0xFF	0x01	LED time Byte3	LED time Byte2	LED time Byte1	LED time Byte0	--

LED power on time: [Byte3] [Byte2] [Byte1] [Byte0] $0 \sim 2^{32}$ hours

5.1.8.5 Current ambient light

This command returns the current ambient light of light sensor.

Command format: **Get**

Byte number	1	2	3	4	5	6	7
Byte Definition	Sync	Addr	Cmd1	Cmd2	Data1	Data2	ChkSum
Query ambient light	0xFF	0x01	0x0C	0x6F	0x00	0x00	--

Response Format:

Byte number	1	2	3	4	5	6	7
Byte Definition	Sync	Addr	Resp1	Resp2	Data1	Data2	ChkSum
Extended Response	0xFF	0x01	0x00	0x00	0x00	Ambient light %	--

Ambient light percentage: $0 \sim 100\%$

5.1.8.6 Boot count

Command format: **Get**

Byte number	1	2	3	4	5	6	7
Byte Definition	Sync	Addr	Cmd1	Cmd2	Data1	Data2	ChkSum
Query boot count	0xFF	0x01	0x0E	0x6F	0x00	0x00	--

Response Format:

Byte number	1	2	3	4	5	6	7
Byte Definition	Sync	Addr	Resp1	Resp2	Data1	Data2	ChkSum
Extended Response	0xFF	0x01	0x00	0x00	Bootcount MSB	Bootcount LSB	--

Command format: **Clear**

Byte number	1	2	3	4	5	6	7
Byte Definition	Sync	Addr	Cmd1	Cmd2	Data1	Data2	ChkSum
Clear boot count	0xFF	0x01	0x8E	0x6F	0x00	0x00	--

Response Format:

Byte number	1	2	3	4
Byte Definition	Sync	Addr	Faults	ChkSum
General Response	0xFF	0x01	--	--

5.1.4.8.7 LED voltage

Command format: **Get**

Byte number	1	2	3	4	5	6	7
Byte Definition	Sync	Addr	Cmd1	Cmd2	Data1	Data2	ChkSum
Query LED1 voltage	0xFF	0x01	0x10	0x6F	0x00	0x00	--

Response Format:

Byte number	1	2	3	4	5	6	7
Byte Definition	Sync	Addr	Resp1	Resp2	Data1	Data2	ChkSum
Extended Response	0xFF	0x01	0x00	0x00	Voltage MSB	Voltage LSB	--

Voltage is in mV.

Command format: **Get**

Byte number	1	2	3	4	5	6	7
Byte Definition	Sync	Addr	Cmd1	Cmd2	Data1	Data2	ChkSum
Query LED2 voltage	0xFF	0x01	0x12	0x6F	0x00	0x00	--

Response Format:

Byte number	1	2	3	4	5	6	7
Byte Definition	Sync	Addr	Resp1	Resp2	Data1	Data2	ChkSum
Extended Response	0xFF	0x01	0x00	0x00	Voltage MSB	Voltage LSB	--

Voltage is in mV.

Command format: **Get**

Byte number	1	2	3	4	5	6	7
Byte Definition	Sync	Addr	Cmd1	Cmd2	Data1	Data2	ChkSum
Query LED3 voltage	0xFF	0x01	0x14	0x6F	0x00	0x00	--

Response Format:

Byte number	1	2	3	4	5	6	7
Byte Definition	Sync	Addr	Resp1	Resp2	Data1	Data2	ChkSum
Extended Response	0xFF	0x01	0x00	0x00	Voltage MSB	Voltage LSB	--

Voltage is in mV.

Command format: **Get**

Byte number	1	2	3	4	5	6	7
Byte Definition	Sync	Addr	Cmd1	Cmd2	Data1	Data2	ChkSum
Query LED4 voltage	0xFF	0x01	0x16	0x6F	0x00	0x00	--

Response Format:

Byte number	1	2	3	4	5	6	7
Byte Definition	Sync	Addr	Resp1	Resp2	Data1	Data2	ChkSum
Extended Response	0xFF	0x01	0x00	0x00	Voltage MSB	Voltage LSB	--

Voltage is in mV.

5.1.8.8 System error code

Command format: **Get**

Byte number	1	2	3	4	5	6	7
Byte Definition	Sync	Addr	Cmd1	Cmd2	Data1	Data2	ChkSum
Query system error code	0xFF	0x01	0x18	0x6F	0x00	0x00	--

Response Format:

Byte number	1	2	3	4	5	6	7
Byte Definition	Sync	Addr	Resp1	Resp2	Data1	Data2	ChkSum
Extended Response	0xFF	0x01	Error byte3	Error byte2	Error byte1	Error byte0	--

Error code: [byte3][byte2][byte1][byte0]

/** Error code **/

```
#define ErrorCode_None      0x00000000 //System is OK
```

```
//system or module
```

```
#define ErrorCode_WDTimeout_bm  0x00000001 //internal watchdog
```

```
#define ErrorCode_RTC_CalibFailCmd_bm 0x00000002 //MCU uart1 rx buffer overflow
```

```
#define ErrirCode_EEPROM_WrFail_bm  0x00000004 //can't write into EEPROM
```

```
//LED functions
```

```
#define ErrorCode_OVP1_bm      0x00000100 //LED driver's OVP voltage is exceed 1.2V
```

```
#define ErrorCode_OVP2_bm      0x00000200 //LED driver's OVP voltage is exceed 1.2V
```

```
#define ErrorCode_OVP3_bm      0x00000400 //LED driver's OVP voltage is exceed 1.2V
```

```
#define ErrorCode_OVP4_bm      0x00000800 //LED driver's OVP voltage is exceed 1.2V
```

```
#define ErrorCode_LED_OverTemp  0x00001000 //over-temperature
```

```
#define ErrorCode_LED_UnderTemp 0x00002000 //under-temperature
```

```
//Peripheral
#define ErrorCode_LowPowerSupply_bm 0x00010000 //Power loss have occurred
#define ErrorCode_TempSensorFail_bm 0x00020000 //Read ID of temperature sensor is fail
#define ErrorCode_MCU_OverTemp 0x00040000 //over-temperature
#define ErrorCode_MCU_UnderTemp 0x00080000 //under-temperature
```

5.1.8.9 Count of over-heat and input voltage out of range

Command format: **Get**

Byte number	1	2	3	4	5	6	7
Byte Definition	Sync	Addr	Cmd1	Cmd2	Data1	Data2	ChkSum
Query VIN/Temp. over range count	0xFF	0x01	0x1A	0x6F	0x00	0x00	--

Response Format:

Byte number	1	2	3	4	5	6	7
Byte Definition	Sync	Addr	Resp1	Resp2	Data1	Data2	ChkSum
Extended Response	0xFF	0x01	0x00	VIN count	0x00	Temp. count	--

VIN: Input voltage

Temp: Temperature of LED

Command format: **Clear**

Byte number	1	2	3	4	5	6	7
Byte Definition	Sync	Addr	Cmd1	Cmd2	Data1	Data2	ChkSum
Clear VIN/Temp. over range count	0xFF	0x01	0x9A	0x6F	VIN	Temp	--

Response Format:

Byte number	1	2	3	4
Byte Definition	Sync	Addr	Faults	ChkSum
General Response	0xFF	0x01	--	--

Set VIN or Temp bit with 1 to clear count

Command format: **Get**

Byte number	1	2	3	4	5	6	7
Byte Definition	Sync	Addr	Cmd1	Cmd2	Data1	Data2	ChkSum
Query OVP over range count	0xFF	0x01	0x1C	0x6F	0x00	0x00	--

Response Format:

Byte number	1	2	3	4	5	6	7
Byte Definition	Sync	Addr	Resp1	Resp2	Data1	Data2	ChkSum
Extended Response	0xFF	0x01	LED1 count	LED2 count	LED3 count	LED4 count	--

Command format: **Clear**

Byte number	1	2	3	4	5	6	7
Byte Definition	Sync	Addr	Cmd1	Cmd2	Data1	Data2	ChkSum
Clear OVP count	0xFF	0x01	0x9C	0x6F	0x00	0x00	--

Response Format:

Byte number	1	2	3	4
Byte Definition	Sync	Addr	Faults	ChkSum
General Response	0xFF	0x01	--	--

5.1.9 Query Version information (0x73)

This command returns CaMate's series number, Model ID, Firmware revision, Max/default current, Lens tele/wide angle, Factory date, Factory time.

5.1.9.1 Firmware revision

Command format: **Get**

Byte number	1	2	3	4	5	6	7
Byte Definition	Sync	Addr	Cmd1	Cmd2	Data1	Data2	ChkSum
Query FW Version	0xFF	0x01	0x02	0x73	0x00	0x00	--

Response Format:

Byte number	1	2	3	4	5	6	7
Byte Definition	Sync	Addr	Resp1	Resp2	Data1	Data2	ChkSum
Extended Response	0xFF	0x01	FW Major	FW Minor	FW Chks MSB	FW Chks LSB	--

FW: firmware, Chks: checksum

5.1.9.2 Boot loader revision

Command format: **Get**

Byte number	1	2	3	4	5	6	7
Byte Definition	Sync	Addr	Cmd1	Cmd2	Data1	Data2	ChkSum
Query BL Version	0xFF	0x01	0x04	0x73	0x00	0x00	--

Response Format:

Byte number	1	2	3	4	5	6	7
Byte Definition	Sync	Addr	Resp1	Resp2	Data1	Data2	ChkSum
Extended Response	0xFF	0x01	FW Major	FW Minor	FW Build MSB	FW Build LSB	--

BL: boot loader, Chks: checksum

5.1.9.3 Hardware revision

Command format: **Get**

Byte number	1	2	3	4	5	6	7
Byte Definition	Sync	Addr	Cmd1	Cmd2	Data1	Data2	ChkSum
Query HW Version	0xFF	0x01	0x06	0x73	0x00	0x00	--

Response Format:

Byte number	1	2	3	4	5	6	7
Byte Definition	Sync	Addr	Resp1	Resp2	Data1	Data2	ChkSum
Extended Response	0xFF	0x01	0x07	0x00	HW Rev MSB	HW Rev LSB	--

HW: Hardware, Chks: checksum

5.1.9.4 Serial number

Command format: **Get**

Byte number	1	2	3	4	5	6	7
Byte Definition	Sync	Addr	Cmd1	Cmd2	Data1	Data2	ChkSum
Query Serial Number - MSB	0xFF	0x01	0x08	0x73	0x00	0x00	--

Response Format:

Byte number	1	2	3	4	5	6	7
Byte Definition	Sync	Addr	Resp1	Resp2	Data1	Data2	ChkSum
Extended Response	0xFF	0x01	Serial # Byte7	Serial # Byte6	Serial # Byte5	Serial # Byte4	--

Command format: **Get**

Byte number	1	2	3	4	5	6	7
Byte Definition	Sync	Addr	Cmd1	Cmd2	Data1	Data2	ChkSum
Query Serial Number - LSB	0xFF	0x01	0x0A	0x73	0x00	0x00	--

Response Format:

Byte number	1	2	3	4	5	6	7
Byte Definition	Sync	Addr	Resp1	Resp2	Data1	Data2	ChkSum
Extended Response	0xFF	0x01	Serial # Byte3	Serial # Byte2	Serial # Byte1	Serial # Byte0	--

Serial number: [Byte7] [Byte6][Byte5] [Byte4][Byte3] [Byte2] [Byte1] [Byte0]

5.1.9.5 Model ID

Command format: **Get**

Byte number	1	2	3	4	5	6	7
Byte Definition	Sync	Addr	Cmd1	Cmd2	Data1	Data2	ChkSum
Query Model ID	0xFF	0x01	0x10	0x73	0x00	0x00	--

Response Format:

Byte number	1	2	3	4	5	6	7
Byte Definition	Sync	Addr	Resp1	Resp2	Data1	Data2	ChkSum
Extended Response	0xFF	0x01	Model ID Byte3	Model ID Byte2	Model ID Byte1	Model ID Byte0	--

5.1.9.6 Maximum/Default LED current

Command format: **Get**

Byte number	1	2	3	4	5	6	7
Byte Definition	Sync	Addr	Cmd1	Cmd2	Data1	Data2	ChkSum
Query Max./Default Current	0xFF	0x01	0x14	0x73	0x00	0x00	--

Response Format:

Byte number	1	2	3	4	5	6	7
Byte Definition	Sync	Addr	Resp1	Resp2	Data1	Data2	ChkSum
Extended Response	0xFF	0x01	0x00	Max. current	0x00	Default current	--

5.1.9.7 Lens angle information

Command format: **Get**

Byte number	1	2	3	4	5	6	7
Byte Definition	Sync	Addr	Cmd1	Cmd2	Data1	Data2	ChkSum
Query Lens angle	0xFF	0x01	0x16	0x73	0x00	0x00	--

Response Format:

Byte number	1	2	3	4	5	6	7
Byte Definition	Sync	Addr	Resp1	Resp2	Data1	Data2	ChkSum
Extended Response	0xFF	0x01	0x00	Tele angle	0x00	Wide angle	--

5.1.9.8 Factory date

Command format: **Get**

Byte number	1	2	3	4	5	6	7
Byte Definition	Sync	Addr	Cmd1	Cmd2	Data1	Data2	ChkSum
Query Factory Date	0xFF	0x01	0x18	0x73	0x00	0x00	--

Response Format:

Byte number	1	2	3	4	5	6	7
Byte Definition	Sync	Addr	Resp1	Resp2	Data1	Data2	ChkSum
Extended Response	0xFF	0x01	Year MSB	Year LSB	Month	Day	--

5.1.9.9 Factory time

Command format: **Get**

Byte number	1	2	3	4	5	6	7
Byte Definition	Sync	Addr	Cmd1	Cmd2	Data1	Data2	ChkSum
Query Factory Time	0xFF	0x01	0x1C	0x73	0x00	0x00	--

Response Format:

Byte number	1	2	3	4	5	6	7
Byte Definition	Sync	Addr	Resp1	Resp2	Data1	Data2	ChkSum
Extended Response	0xFF	0x01	0x00	Hour	Minute	Second	--

5.1.10 Set brightness level (0x7D)

This command set CaMate's brightness level to the desired percentage.

Byte number	1	2	3	4	5	6	7
Byte Definition	Sync	Addr	Cmd1	Cmd2	Data1	Data2	ChkSum
Set brightness level	0xFF	0x01	0x00	0x7D	0x00	Brightness %	--

Response Format:

Byte number	1	2	3	4
Byte Definition	Sync	Addr	Faults	ChkSum
General Response	0xFF	0x01	--	--

5.1.11 Set ambient threshold level (0x7F)

This command set CaMate's ambient threshold level to the desired percentage.

Byte number	1	2	3	4	5	6	7
Byte Definition	Sync	Addr	Cmd1	Cmd2	Data1	Data2	ChkSum
Set Factory Time - hour	0xFF	0x01	0x00	0x7F	0x00	Threshold %	--

Response Format:

Byte number	1	2	3	4
Byte Definition	Sync	Addr	Faults	ChkSum
General Response	0xFF	0x01	--	--

5.1.12 Get brightness level (0x81)

This command will return current brightness level percentage in byte 6 of returned extended response.

Command format:

Byte number	1	2	3	4	5	6	7
Byte Definition	Sync	Addr	Cmd1	Cmd2	Data1	Data2	ChkSum
Query ambient threshold	0xFF	0x01	0x00	0x81	0x00	0x00	--

Response Format:

Byte number	1	2	3	4	5	6	7
Byte Definition	Sync	Addr	Resp1	Resp2	Data1	Data2	ChkSum
Extended Response	0xFF	0x01	0x00	0x85	0x00	Brightness %	--

5.1.13 Get ambient threshold (0x83)

Command format:

Byte number	1	2	3	4	5	6	7
Byte Definition	Sync	Addr	Cmd1	Cmd2	Data1	Data2	ChkSum
Query ambient threshold	0xFF	0x01	0x00	0x83	0x00	0x00	--

Response Format:

Byte number	1	2	3	4	5	6	7
Byte Definition	Sync	Addr	Resp1	Resp2	Data1	Data2	ChkSum
Extended Response	0xFF	0x01	0x00	0x87	0x00	Threshold %	--

5.2 Appendix B: Command set of CaMate

Protocol:

To avoid communication conflicts when several devices trying to send data at the same time, all transmission and reception are controlled by the host computer. The basic form is a command/response protocol with the host initiating the sequence. When the CaMate devices are not transmitting, they are in the listening mode. The host sends a command to CaMate with a specified address and waits a certain amount of time for the CaMate devices to respond.

The format for a command is:

Byte1	Byte2	Byte3	Byte4	Byte5	Byte6	Byte7	Byte8
Sync Byte	Address	Command	Data1	Data2	Data3	Data4	Checksum

All values below are shown in hexadecimal.

The synchronization byte is always 0xFF.

The address is the logical address of the CaMate being controlled.

The checksum is the 8-bit sum of the payload bytes (bytes2 through 7) in the command.

Command set Table: default address is 0x01

Command Name	Command Syntax	Description
Software Reset	FF 01 10 00 00 00 01 12	
Read Serial No	FF 01 14 00 00 00 00 15	Reply: FF 01 14 (data) chks, data: 16-bytes
Read Model ID	FF 01 15 00 00 00 00 16	Reply: FF 01 15 dd dd dd dd chks, dddd dddd = model ID
Read F/W version	FF 01 16 00 00 00 00 17	Reply: FF 01 16 dd dd cc cc chks, dddd: version, cccc: checksum
Read Max/Default current	FF 01 17 00 00 00 00 18	Reply: FF 01 17 00 mm 00 cc chks, mm: percentage of max current , cc: percentage of default current
Read Lens angle	FF 01 18 00 00 00 00 19	Reply: FF 01 18 pp qq rr ss chks, unit: degree pp: Lens1 tele angle, qq: Lens1 wide angle rr: Lens2 tele angle, ss: Lens2 wide angle
Read Factory date	FF 01 19 00 00 00 00 1A	Reply: FF 01 19 yy yy mm dd chks, yyyy/mm/dd = year/month/day
Read Factory time	FF 01 1A 00 00 00 00 1B	Reply: FF 01 1A 00 hh mm ss chks, hh/mm/ss = hours/minutes/seconds
Read Configuration Data	FF 01 20 00 00 00 00 21	Reply: FF 01 20 dd dd dd dd chks, dddd dddd: 32-bit configuration data
Write Configuration Data	FF 01 21 dd dd dd dd chks	configuration data dddd dddd: (bold font is default value) bit 31~24: Device ID (01)~(127) bit 23~21: Baudrate (bps)

		<p>(0)1200/(1)2400/(2)4800/(3)9600/(4)19200/(5)38400/(6)57600/(7)15200</p> <p>bit 20~16: Brightness (0)20~(31)100%, unit=2.5%</p> <p>bit 15~13: LED control mode (0)DI/(1)Direct/(2)Timer/(3) Light Sensor</p> <p>bit 12: LED status (1)on/ (0)off READ ONLY</p> <p>bit 11~10: Fade inout (0)Off/(1)Fast/(2)Slow</p> <p>bit 9: DI active polarity (1)Hi/(0)Lo, bit 8: DO active polarity (1)Hi/(0)Lo</p> <p>bit 7~6: Reserved</p> <p>bit 5~4: DO mode (0)Light sensor state/ (1)LED state/ (2)Diagnostic</p> <p>bit 3~1: Light sensor threshold (6)infinite/ (5)100/ (4)50/ (3)20/ (2)10/ (1)5/ (0)1 %</p> <p>bit 0: LED indicator control (1)on/ (0)off</p>
Read Clock Date	FF 01 22 00 00 00 00 23	Reply: FF 01 22 yy yy mm dd chks, yyyy/mm/dd = year/month/day
Write Clock Date	FF 01 23 yy yy mm dd chks	yyyy/mm/dd = year/month/day
Read Clock Time	FF 01 24 00 00 00 00 25	Reply: FF 01 24 00 hh mm ss chks, hh/mm/ss = hours/minutes/seconds
Write Clock Time	FF 01 25 00 hh mm ss chks	hh/mm/ss = hours/minutes/seconds
Write LED Status	FF 01 27 00 00 00 0d chks	d: (1) on, (0)off
Read Lens position and motor speed	FF 01 28 00 00 00 00 chks	Reply: FF 01 28 00 mm 00 nn chks, mm: Lens position, mapping to Lens angle range Wide (0x00) ~ Tele (0xFF) nn: motor speed SLOW(0) ~ FAST(3)
Write Lens position and motor speed	FF 01 29 00 mm 00 nn chks	mm: Lens position, mapping to Lens angle range Wide (0x00) ~ Tele (0xFF) nn: motor speed SLOW(0) ~ FAST(3)
Read LED on timer	FF 01 2A 00 00 00 00 2B	Reply: FF 01 2A 00 hh mm ss chks, hh/mm/ss = hours/minutes/seconds
Write LED on timer	FF 01 2B 00 hh mm ss chks	hh/mm/ss = hours/minutes/seconds
Read LED off timer	FF 01 2C 00 00 00 00 2D	Reply: FF 01 2C 00 hh mm ss chks, hh/mm/ss = hours/minutes/seconds
Write LED off timer	FF 01 2D 00 hh mm ss chks	hh/mm/ss = hours/minutes/seconds
Read Temperature	FF 01 30 00 00 00 00 31	Reply: FF 01 30 pp qq rr ss chks,

		<p>temperature value in 2's complement</p> <p>pp: max. LED temperature, qq: current LED temperature, rr: max. MCU temperature, ss: current MCU temperature</p>
Read AC/DC max/avg. voltage	FF 01 31 00 00 00 00 32	<p>Reply: FF 01 31 mm mm nn nn chks,</p> <p>mmmm: max. voltage (in mV)</p> <p>nnnn: average voltage (in mV)</p>
Read AC/DC current voltage	FF 01 32 00 00 00 00 33	<p>Reply: FF 01 32 rr rr pp pp chks</p> <p>pppp: current voltage (in mV)</p> <p>rrrr: min. voltage (in mV)</p>
Read Total System power on time	FF 01 35 00 00 00 00 36	<p>Reply: FF 01 36 hh hh hh hh chks,</p> <p>hhhh hhhh: 0~232 hours</p>
Read Total LED on time	FF 01 36 00 00 00 00 37	<p>Reply: FF 01 36 hh hh hh hh chks,</p> <p>hhhh hhhh: 0~232 hours</p>
Read Ambient light	FF 01 37 00 00 00 00 38	<p>Reply: FF 01 37 00 00 00 aa chks,</p> <p>aa: ambient light in %</p>
Read Boot count	FF 01 38 00 00 00 00 39	<p>Reply: FF 01 38 00 00 bb bb chks,</p> <p>bbbb: boot count</p>
Read LED string1 voltage	FF 01 3A 00 00 00 00 3B	<p>Reply: FF 01 3A 00 00 pp pp chks,</p> <p>pppp: current voltage (in mV)</p>
Read LED string2 voltage	FF 01 3B 00 00 00 00 3C	<p>Reply: FF 01 3B 00 00 pp pp chks,</p> <p>pppp: current voltage (in mV)</p>
Read LED string3 voltage	FF 01 3C 00 00 00 00 3D	<p>Reply: FF 01 3C 00 00 pp pp chks,</p> <p>pppp: current voltage (in mV)</p>
Read LED string4 voltage	FF 01 3D 00 00 00 00 3E	<p>Reply: FF 01 3D 00 00 pp pp chks,</p> <p>pppp: current voltage (in mV)</p>
Read Error code	FF 01 3F 00 00 00 00 40	<p>Reply: FF 01 3F ee ee ee ee chks,</p> <p>eeee eeee: 32-bits</p> <p>All zero: System is OK</p> <p>Bit 0: Watchdog Reset</p> <p>Bit 1: MCU RX buffer overflow</p> <p>Bit2: EEPROM write fail</p> <p>Bit8: LED driver1's voltage is out of range</p> <p>Bit9: LED driver2 's voltage is out of range</p> <p>Bit10: LED driver3's voltage is out of range</p>

		Bit11: LED driver4's voltage is out of range Bit17: Temperature sensor read fail
--	--	---