

8-Port 100/1000X SFP + 2-Port 10/100/1000T Managed Metro Ethernet Switch

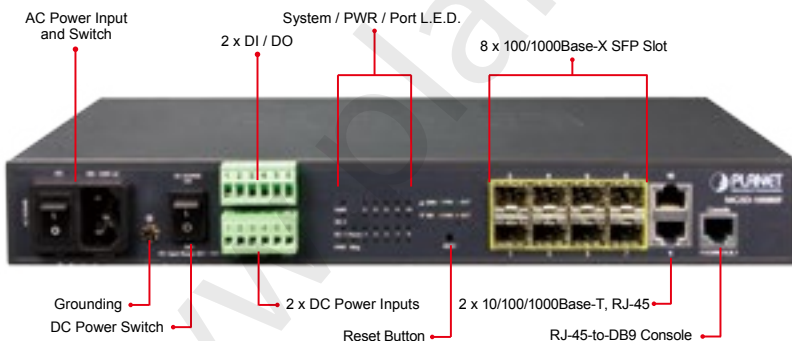

Multiple SFP Fiber Port Switch for Enterprises, Telecoms and Campuses

PLANET's latest Metro series Ethernet switch - the MGSD-10080F - is equipped with advanced management functions and provides 8 100/1000Mbps dual speed SFP Fiber ports, and 2 10/100/1000Mbps TP ports enclosed in a metal encasement. It is capable of providing non-blocking switch fabric and wire-speed throughput as high as 20Gbps in temperatures ranging from -10 to 60 degrees C without any packet loss and CRC errors, greatly simplifying the tasks of upgrading an enterprise LAN that supports the increase in bandwidth demands. The MGSD-10080F is especially designed for service providers seeking to deliver a long distance Ethernet network. The MGSD-10080F adopts a "Front Access" design, which makes accessing the wiring and maintaining the MGSD-10080F placed in a cabinet easy for technicians.



Physical Port

- 8 100/1000Base-X SFP mini-GBIC slots
- 2-Port 10/100/1000Base-T Gigabit Ethernet RJ-45
- One RJ-45 console interface for basic management and setup

Redundant Power System

- Redundant Power System: 100V ~ 240V AC / Dual 36V ~ 72V DC
- Active-active redundant power failure protection
- Backup of catastrophic power failure on one supply
- Fault tolerance and resilience.

Digital Input / Digital Output

- 2 Digital Input (DI)
- 2 Digital Output (DO)
- Integrates sensors into auto alarm system
- Transfer alarm to IP network via SNMP trap

Hardware Design

- -10 to 60 degrees C operating temperature for DC power input only
- 13-inch desktop size, 19-inch Rack-mountable
- Relay alarm for port breakdown, power failure
- Fanless design

Layer 2 Features

- Prevents packet loss with back pressure (Half-Duplex) and IEEE 802.3x PAUSE frame flow control (Full-Duplex)
- High performance of Store-and-Forward architecture and runt/CRC filtering eliminate erroneous packets to optimize the network bandwidth
- Storm Control support
 - Broadcast / Multicast / Unicast

Flexible and Extendable Solution

With 8 built-in mini-GBIC slots, the MGSD-10080F supports Dual-Speed, 100Base-FX and 1000Base-SX/LX SFP (Small Form-factor Pluggable) fiber-optic modules. This enables administrators to choose the suitable SFP transceivers according to the transmission distance or the transmission speed requirements. The MGSD-10080F supports the SFP-DDM (Digital Diagnostic Monitor) function which can easily monitor real-time parameters such as optical output power, optical input power, temperature, laser bias current, and transceiver supply voltage for network administrator.

Digital Diagnostic Monitor (DDM)

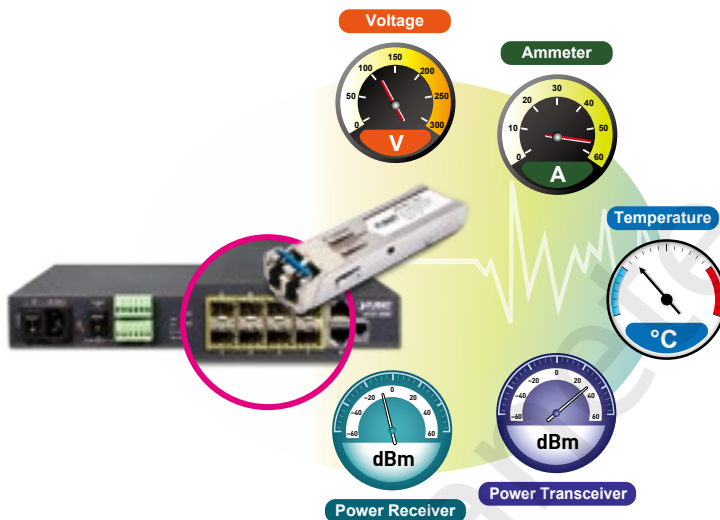

AC and DC Redundant Power to Ensure Continuous Operation

To enhance operation reliability and flexibility, the MGSD-10080F is equipped with one 100 ~ 240V AC power supply unit and two additional 36 ~ 72V DC power input connectors for redundant power supply installation. The Redundant Power Systems are specifically designed to handle the demands of high tech facilities requiring high power integrity. In addition, with its 36 ~ 72V DC power supply, the MGSD-10080F can be utilized as a telecom device that can be located in an electrical room.

Digital Input and Digital Output for External Alarm

The MGSD-10080F supports Digital Input, and Digital Output on the front panel. The external alarm offers technicians the ability to use Digital Input to detect, and log external device statuses (such as door intrusion detection) for the alarm and Digital Output could be used to alarm if the MGSD-10080F has a port link down, link up or power failure.

- Supports VLAN
 - IEEE 802.1Q Tagged VLAN
 - Up to 255 VLANs groups, out of 4094 VLAN IDs
 - Provider Bridging (VLAN Q-in-Q) support (IEEE 802.1ad)
 - Private VLAN Edge (PVE)
 - Protocol-based VLAN
 - MAC-based VLAN
 - Voice VLAN
- Supports Spanning Tree Protocol
 - STP, IEEE 802.1D Spanning Tree Protocol
 - RSTP, IEEE 802.1w Rapid Spanning Tree Protocol
 - MSTP, IEEE 802.1s Multiple Spanning Tree Protocol, spanning tree by VLAN
 - BPDU Guard
- Supports Link Aggregation
 - 802.3ad Link Aggregation Control Protocol (LACP)
 - Cisco ether-channel (Static Trunk)
 - Maximum 5 trunk groups, up to 8 ports per trunk group
 - Up to 16Gbps bandwidth (Duplex Mode)
- Provides Port Mirror (1-to-1)
- Port Mirroring to monitor the incoming or outgoing traffic on a particular port
- Loop protection to avoid broadcast loops

Quality of Service

- Ingress Shaper and Egress Rate Limit per port bandwidth control
- 8 priority queues on all switch ports
- Traffic classification
 - IEEE 802.1p CoS
 - IP TOS / DSCP / IP Precedence
 - IP TCP/UDP port number
 - Typical network application
- Strict priority and Weighted Round Robin (WRR) CoS policies

Digital Input

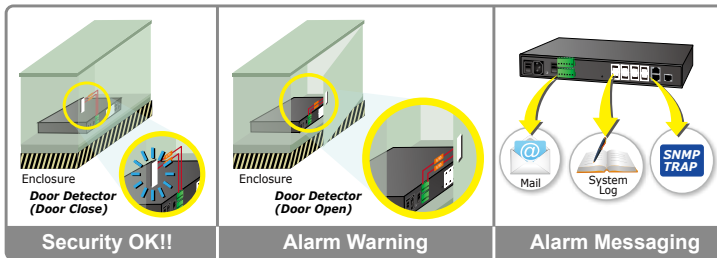

Digital Output

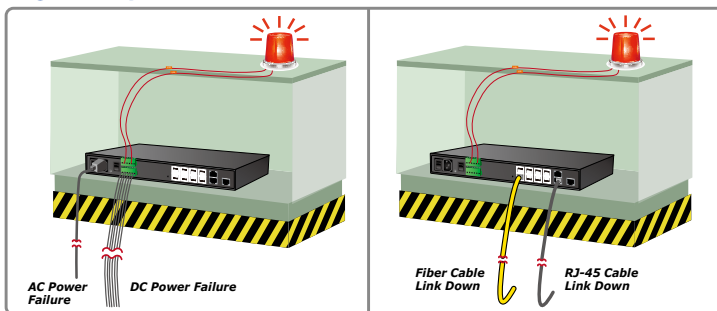

Cost-effective IPv6 Managed Gigabit Switch Solution for Metro Ethernet

To fulfill the demand for ISPs to quickly build IPv6 (Internet Protocol version 6) network infrastructures, the MGSD-10080F supports both IPv4 and IPv6 management functions. It can work with original IPv4 network structures and also support newer IPv6 network structures. With easy user-friendly management interfaces and its integrated management functions, the MGSD-10080F Metro Ethernet Switch is the best choice for ISPs and service providers to build an IPv6 FTTx edge service or for Industries to connect with an IPv6 network.

Layer 2 / Layer 4 Full-functioned Managed Switch for Building

Automation Networking

The MGSD-10080F Managed Ethernet Switch is also ideal for applications in the factory data centers and distributions. It provides advanced Layer 2 to Layer 4 data switching and redundancy, Quality of Service traffic control, network access control, authentication, and secure management features to protect a customer's Automated Ethernet network connectivity and offer reliable switching recovery capabilities that are suitable for implementing fault tolerant and mesh network architectures.

Powerful Security

The MGSD-10080F offers a comprehensive Access Control List (ACL) for enforcing maximum security. Its protection mechanisms also comprise of port-based 802.1x and MAC-based user and device authentication. Port-security limits the number of clients passing through and allows network administrators to construct highly secure corporate networks in considerably less time and effort than before.

- Supports QoS and In/Out bandwidth control on each port
- Traffic-policing policies on the switch port
- DSCP remarking

Multicast

- Supports IGMP Snooping v1, v2 and v3
- Supports MLD Snooping v1 and v2
- Querier mode support
- IGMP Snooping port filtering
- MLD Snooping port filtering
- MVR (Multicast VLAN Registration)

Security

- IEEE 802.1x Port-based / MAC-based network access authentication
- Built-in RADIUS client to co-operate with the RADIUS servers
- RADIUS / TACACS+ users access authentication
- IP-based Access Control List (ACL)
- MAC-based Access Control List
- Source MAC / IP address binding
- DHCP Snooping to filter untrusted DHCP messages
- Dynamic ARP Inspection discards ARP packets with invalid MAC address to IP address binding
- IP Source Guard prevents IP spoofing attacks
- IP address access management to prevent unauthorized intruder

Management

- Switch Management Interfaces
 - Console / Telnet Command Line Interface
 - Web switch management
 - SNMP v1 and v2c switch management
 - SSH / SSL and SNMP v3 secure access
- Four RMON groups (history, statistics, alarms, and events)
- IPv6 IP Address / NTP / DNS management
- Built-in Trivial File Transfer Protocol (TFTP) client

Application

Optimized Design for Metropolitan Area Network

With Optical Fiber Ethernet's highly-flexible, highly-extendable and easy-installation features, the MGSD-10080F offers data exchange at a speed of Optical Fiber (up to 1Gbps), and distances of Gigabit Optical Fiber (up to 120km). The device supports service providers, such as ISPs and Telecom, to install Metropolitan Area Networks (MAN) based on Fiber technology to the WAN Internet Service.

Metropolitan Area Network Application

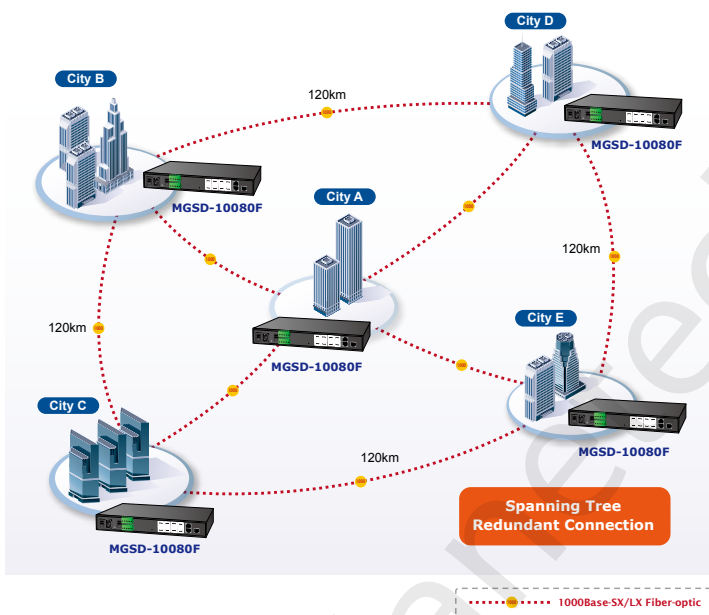

Excellent Solution for Core / Department Switch

With 10 Gigabit ports, the MGSD-10080F is able to connect up to 10 edge switches in an Ethernet environment. In addition, the MGSD-10080F offers a switch fabric with throughput of 20 Gigabits per second and provides high bandwidth for a backbone connection. The MGSD-10080F is an excellent choice for a core layer switch in a Gigabit network.

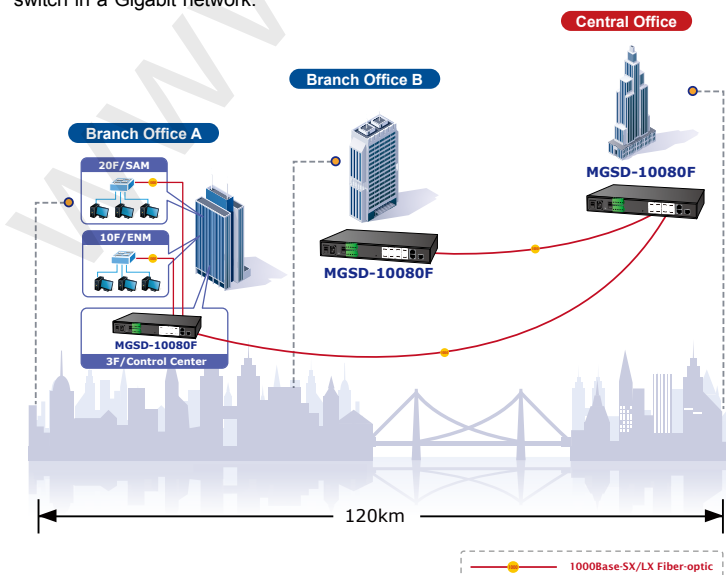

- BOOTP and DHCP for IP address assignment
- Firmware upload / download via HTTP / TFTP
- DHCP Relay
- DHCP Option 82
- User Privilege levels control
- NTP (Network Time Protocol)
- Link Layer Discovery Protocol (LLDP) Protocol
- SFP-DDM (Digital Diagnostic Monitor)
- Cable Diagnostic technology provides the mechanism to detect and report potential cabling issues
- Reset button for system reboot or reset to factory default
- PLANET Smart Discovery Utility for deploy management

Product Specifications

Model	MGSD-10080F
Hardware Specification	
SFP/mini-GBIC Slots	8 1000Base-SX/LX/BX SFP interfaces, from port 1 to port 8 Compatible with 100Base-FX SFP
Copper Ports	2 10/ 100/1000Base-T RJ-45 Auto-MDI/MDI-X ports
Console Port	1 x RJ-45-to-RS-232 serial port (115200, 8, N, 1)
Switch Architecture	Store-and-Forward
Throughput (packet per second)	14.8Mpps @ 64Bytes packet
Switch Fabric	20Gbps / non-blocking
Address Table	8K entries, automatic source address learning and ageing
Share Data Buffer	4Mbits
Flow Control	IEEE 802.3x Pause Frame for Full-Duplex Back pressure for Half-Duplex
Jumbo Frame	9Kbytes
Reset Button	< 5 seconds: System Reboot > 10 seconds: Factory Default
Dimensions (W x D x H)	330 x 155 x 43.5 mm, 1U high
Weight	1661g
LED Indicator	System: PWR (Green) DC 1 (Green) DC 2 (Green) Fault Alarm (Green) Ring* (Green) Ring Owner* (Green) Per Gigabit Ports: 100 LNK/ACT (Orange) 1000 LNK/ACT (Green)
Power Consumption	Max. 11.2 Watts / 38.2 BTU (AC input) Max. 10.8 Watts / 36.9 BTU (DC input)
Power Requirements	AC 100~240V, 50/60Hz 0.15A -36V DC @ 0.3A, Range: -36V ~ -72V DC
Alarm	One relay output for power failure. Alarm Relay current carry ability: 1A @ DC 24V
DI/DO	2 Digital Input (DI) : Level 0: -24V~2.1V (±0.1V) Level 1: 2.1V~24V (±0.1V) Input Load to 24V DC, 10mA max. 2 Digital Output (DO) : Open collector to 24VDC, 100mA max.
Layer 2 Function	
Port Configuration	Port disable / enable Auto-Negotiation 10/100/1000Mbps full and half duplex mode selection Flow Control disable / enable Bandwidth control on each port Power saving mode control
Port Status	Display each port's speed duplex mode, link status, flow control status, auto negotiation status, trunk status
Port Mirroring	TX / RX / Both 1 to 1 monitor
VLAN	802.1Q Tagged Based VLAN, up to 255 VLAN groups Q-in-Q tunneling Private VLAN Edge (PVE) MAC-based VLAN Protocol-based VLAN Voice VLAN MVR (Multicast VLAN Registration) Up to 255 VLAN groups, out of 4094 VLAN IDs
Link Aggregation	IEEE 802.3ad LACP / Static Trunk Supports 5 groups of 8-Port trunk support

QoS	Traffic classification based, Strict priority and WRR 8-Level priority for switching - Port Number - 802.1p priority - 802.1Q VLAN tag - DSCP/TOS field in IP Packet
IGMP Snooping	IGMP (v1/v2/V3) Snooping, up to 255 multicast Groups IGMP Querier mode support
MLD Snooping	MLD (v1/v2) Snooping, up to 255 multicast Groups MLD Querier mode support
Access Control List	IP-based ACL / MAC-based ACL Up to 123 entries
Bandwidth Control	Per port bandwidth control Ingress: 500Kb~1000Mbps Egress: 500Kb~1000Mbps
Management	
Basic Management Interfaces	Console, Telnet, Web Browser, SNMP v1, v2c and v3
Secure Management Interface	SSH, SSL, SNMP v3
SNMP MIBs	RFC-1213 MIB-II IF-MIB RFC-1493 Bridge MIB RFC-1643 Ethernet MIB RFC-2863 Interface MIB RFC-2665 Ether-Like MIB RFC-2819 RMON MIB (Group 1) RFC-2737 Entity MIB RFC-2618 RADIUS Client MIB RFC-2933 IGMP-STD-MIB RFC-3411 SNMP-Frameworks-MIB IEEE 802.1X PAE LLDP MAU-MIB
Standards Conformance	
Regulation Compliance	FCC Part 15 Class A, CE
Standards Compliance	IEEE 802.3 10Base-T IEEE 802.3u 100Base-TX/100Base-FX IEEE 802.3z Gigabit SX/LX IEEE 802.3ab Gigabit 1000T IEEE 802.3x Flow Control and Back pressure IEEE 802.3ad Port trunk with LACP IEEE 802.1D Spanning tree protocol IEEE 802.1w Rapid Spanning tree protocol IEEE 802.1s Multiple Spanning tree protocol IEEE 802.1p Class of service IEEE 802.1Q VLAN Tagging IEEE 802.1x Port Authentication Network Control IEEE 802.1ab LLDP RFC 768 UDP RFC 793 TFTP RFC 791 IP RFC 792 ICMP RFC 2068 HTTP RFC 1112 IGMP version 1 RFC 2236 IGMP version 2
Environment	
Operating	Temperature : -10 ~ 60 degrees C for DC power input 0 ~ 50 degrees C for AC power input Relative Humidity : 5 ~ 95% (non-condensing)
Storage	Temperature: -10 ~ 70 degrees C Relative Humidity: 5 ~ 95% (non-condensing)

Ordering Information

MGSD-10080F	8-Port 100/1000X SFP + 2-Port 10/100/1000T Managed Metro Ethernet Switch
-------------	--

Available Modules for MGSD-10080F

• 1000Mbps SFP transceiver modules

MGB-GT	SFP-Port 1000Base-T Module
MGB-SX	SFP-Port 1000Base-SX mini-GBIC module - 550m
MGB-SX2	SFP-Port 1000Base-SX mini-GBIC module - 2km
MGB-LX	SFP-Port 1000Base-LX mini-GBIC module - 10km
MGB-L30	SFP-Port 1000Base-LX mini-GBIC module - 30km
MGB-L50	SFP-Port 1000Base-LX mini-GBIC module - 50km
MGB-L70	SFP-Port 1000Base-LX mini-GBIC module - 70km
MGB-L120	SFP-Port 1000Base-LX mini-GBIC module - 120km
MGB-LA10	SFP-Port 1000Base-LX (WDM,TX:1310nm) mini-GBIC module - 10km
MGB-LB10	SFP-Port 1000Base-LX (WDM,TX:1550nm) mini-GBIC module - 10km
MGB-LA20	SFP-Port 1000Base-LX (WDM,TX:1310nm) mini-GBIC module - 20km
MGB-LB20	SFP-Port 1000Base-LX (WDM,TX:1550nm) mini-GBIC module - 20km
MGB-LA40	SFP-Port 1000Base-LX (WDM,TX:1310nm) mini-GBIC module - 40km
MGB-LB40	SFP-Port 1000Base-LX (WDM,TX:1550nm) mini-GBIC module - 40km
MGB-TSX	SFP-Port 1000Base-SX mini-GBIC module - 550m (-40 ~ 75 degrees C)
MGB-TLX	SFP-Port 1000Base-LX mini-GBIC module - 10km (-40 ~ 75 degrees C)
MGB-TL30	SFP-Port 1000Base-LX mini-GBIC module - 30km (-40 ~ 75 degrees C)
MGB-TL70	SFP-Port 1000Base-LX mini-GBIC module - 70km (-40 ~ 75 degrees C)

• 100Mbps SFP transceiver modules

MFB-FX	SFP-Port 100Base-FX Transceiver (1310nm) - 2km
MFB-F20	SFP-Port 100Base-FX Transceiver (1310nm) - 20km
MFB-F40	SFP-Port 100Base-FX Transceiver (1310nm) - 40km
MFB-F60	SFP-Port 100Base-FX Transceiver (1310nm) - 60km
MFB-FA20	SFP-Port 100Base-BX Transceiver (WDM,TX:1310nm) - 20km
MFB-FB20	SFP-Port 100Base-BX Transceiver (WDM,TX:1550nm) - 20km
MFB-TFX	SFP-Port 100Base-FX Transceiver (1310nm) - 2km (-40 ~ 75 degrees C)
MFB-TF20	SFP-Port 100Base-FX Transceiver (1310nm) - 20km (-40 ~ 75 degrees C)

PLANET Technology Corporation
Headquarters

11F., No.96, Minquan Rd., Xindian Dist.,
New Taipei City 231, Taiwan (R.O.C.)
Tel: 886-2-2219-9518
Email: sales@planet.com.tw
Fax: 886-2-2219-9528

Versa Technology
Authorized North
American Distributor

5224 Bell Court
Chino, California 91710
Tel: 888-229-3183
Email: sales@versatek.com
www.planetechusa.com



PLANET reserves the right to change specifications without prior notice. All brand names and trademarks are property of their respective owners. Copyright © 2013 PLANET Technology Corp. All rights reserved.

MGSD-10080F